

User's Guide

energyPRO

By EMD International A/S

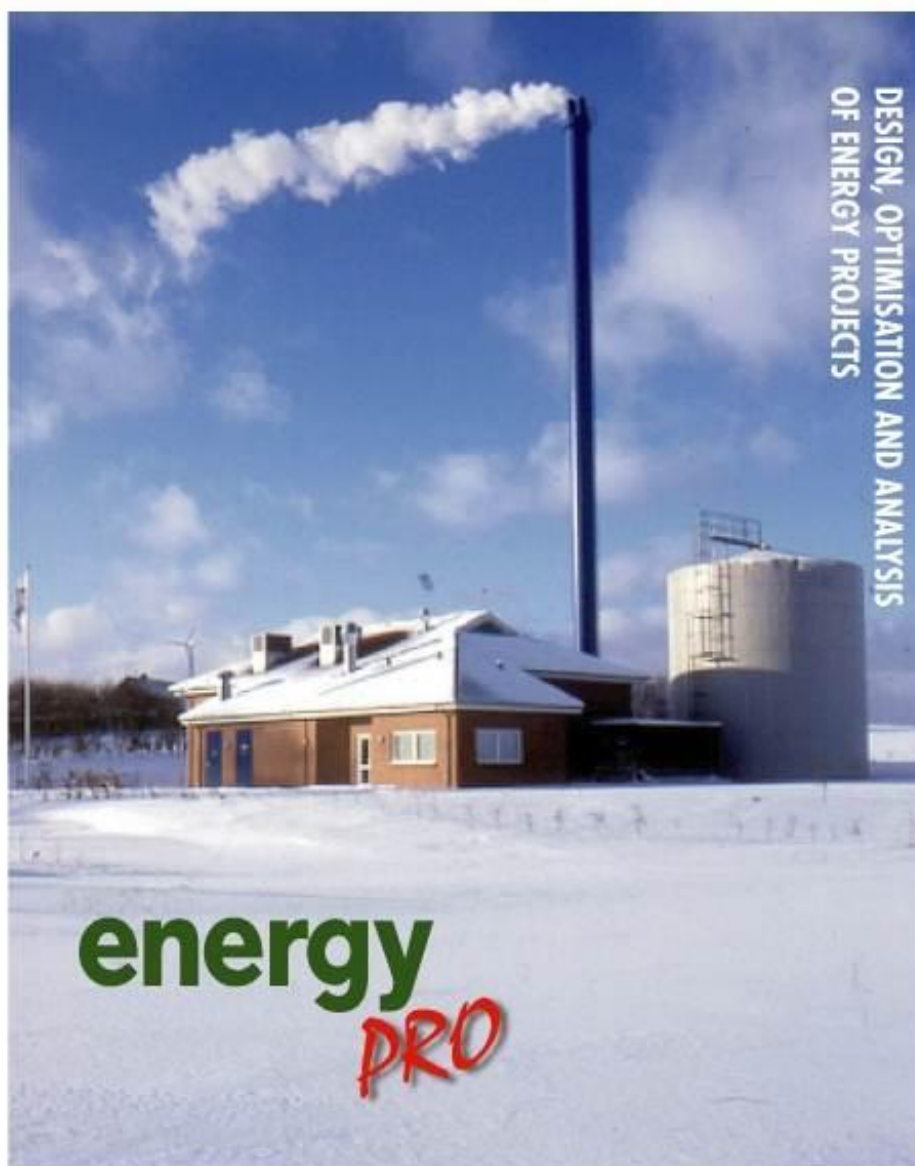

© Copyright and publisher:

EMD International A/S

Niels Jernes vej 10

DK-9220 Aalborg Ø

DENMARK

Phone: +45 9635 4444, fax: +45 9635 4446

e-mail: emd@emd.dk, web: www.emd.dk

Preface

energyPRO is a Windows-based modeling software package for combined techno-economic analysis and optimisation of complex energy projects with a combined supply of electricity and thermal energy from multiple different energy producing units.

The unique programming in energyPRO optimises the operations of the plant including energy storage (heat, fuel, cold and electrical storages) against technical and financial parameters to provide a detailed specification for the provision of the defined energy demands, including heating, cooling and electricity use.

energyPRO also provides the user with a detailed financial plan in a standard format accepted by international banks and funding institutions. The software enables the user to calculate and produce a report for the emissions by the proposed project.

energyPRO is very user-friendly and is the most advanced and flexible software package for making a combined technical and economic analysis of multi-dimensional energy projects.

For further information concerning the applications of energyPRO please visit www.emd.dk.

This User's Guide consists of four chapters and a number of appendices.

- **Chapter 1, "Introduction to energyPRO"** is a general introduction to the energyPRO desktop.
- **Chapter 2, "The energyPRO desktop in details"** describes the facilities in energyPRO window by window, explaining the single input fields.
- **Chapter 3, "Method of calculation in energyPRO"** explains the general principles in energyPRO calculations, including a step-by-step example explaining how the operation strategy is calculated.
- **Chapter 4, "Functions in energyPRO"** serves as a reference section explaining the available functions in energyPRO.

Terms of application

EMD has made every attempt to ensure the accuracy and reliability of the information provided in this Guide. However, the information is provided "as is" without warranty of any kind. EMD does not accept any responsibility or liability for the accuracy, content, completeness, legality, or reliability of the information contained in this Guide.

No warranties, promises and/or representations of any kind, expressed or implied, are given as to the nature, standard, accuracy or otherwise of the information provided in this Guide nor to the suitability or otherwise of the information to your particular circumstances. In no event shall EMD be liable for any loss or damage of whatever nature (direct, indirect, consequential, or other) whether arising in contract, tort or otherwise, which may arise as a result of your use of (or inability to use) this Guide, or from your use of (or failure to use) the information in this Guide.

Contents

1 Introduction to energyPRO	6
1.1 Introduction	6
1.2 Installation	7
1.3 License Conditions	7
1.4 Service and Updates	8
1.5 License activation.....	8
1.6 Auto save and recovery	14
1.7 The energyPRO desktop.....	14
1.7.1 Input data structure	14
1.7.2 The editing windows.....	17
1.7.3 Reports	21
1.8 Graphical editing.....	21
1.8.1 What is included?	22
1.8.2 What about the old way of doing things?	22
1.8.3 A better overview	23
1.8.4 Adjusting View	23
1.8.5 How to edit	25
1.8.6 Add Component	26
1.8.7 Connections.....	28
1.9 Data-sets delivered with energyPRO	31
1.9.1 Finding data the first time	32
1.9.2 Danish Design Reference Year	32
2 The energyPRO desktop in details	35
2.1 Introduction	35
2.2 Menu bar	35
2.2.1 energyPRO setup	35
2.2.2 Window	38
2.2.3 Help (and license activation)	38
2.3 Project Identification	39
2.3.2 Project reports.....	43
2.4 External conditions	45
2.4.1 External conditions – Input form	45
2.4.2 External conditions - Time series.....	48
2.4.3 External conditions – Online Data	54
2.4.4 External conditions - Time series functions.....	57
2.4.5 External conditions - Indexes	59
2.5 Sites 61	
2.5.1 Adding more sites.....	61
2.5.2 Adding transmissions.....	62
2.6 Transmissions	62
2.6.1 Restricting when transmissions can be used.....	63
2.6.2 What about fuel and electricity transmissions?	63
2.7 Fuels 64	
2.7.1 Editing options for editing a specific fuel	64
2.7.2 Editing the data fields	65
2.7.3 Using fuel when defining energy Unit	66

2.8 Demands	66
2.8.1 Demand do NOT depend on external conditions	67
2.8.2 Demand depends on external conditions.....	69
2.8.3 Developing over the years.....	73
2.8.4 Restricted period of connection	73
2.8.5 As graphics – button	74
2.8.6 As time series – button.....	74
2.9 Energy conversion units.....	74
2.9.1 Energy conversion units – in general.....	74
2.9.2 Production units described by load curves.....	76
2.9.3 Production units not described with load curves	81
2.9.4 Heat rejection	93
2.10 Storages	94
2.10.1 Storages in general	94
2.10.2 Thermal store	95
2.10.3 Electrical storage	97
2.10.4 Cold Storage	100
2.11 Electricity Markets – Wholesale markets	100
2.11.1 Fixed Tariffs	101
2.11.2 Spot Market.....	103
2.11.3 More than one “Electricity Market” in a model (MARKETS)	105
2.12 Operation Strategy	105
2.12.1 Operation strategy	107
2.12.2 Heat rejection table.....	113
2.12.3 Miscellaneous table.....	113
2.12.4 The Island Operation Strategy	115
2.13 Environment	116
2.14 Economic input data	118
2.14.1 Facilities in the economic section.....	118
2.14.2 Economy – Main folder:	119
2.15 Revenues and Operational Expenditures.....	124
2.16 Investment.....	130
2.17 Financing.....	131
2.17.1 Financing – Main folder	132
2.17.2 Financing – Loans, Owners capital etc.....	132
2.18 Taxation	135
2.19 Reports.....	137
2.19.1 Introduction.....	137
2.19.2 Reports to Clipboard.....	139
2.19.3 Production, Graphical.....	139
2.19.4 Production, carpets	140
2.19.5 Energy conversion annual	142
2.19.6 Energy Conversion, monthly	143
2.19.7 Energy Conversion, summary	144
2.19.8 Duration curves for Demands.....	145
2.19.9 Environment	145
2.19.10 Economy Reports introduction.....	146
2.19.11 Operation income.....	148
2.19.12 Cash flow, monthly.....	148
2.19.13 Cash flow, graphical.....	149
2.19.14 Financial key figures	150
2.19.15 Income statement	150
2.19.16 Income Statement, summary	151
2.19.17 Balance sheet	152
2.19.18 Balance sheet, summary	152
2.19.19 Catalogue of technical assumptions.....	152
2.19.20 Catalogue of economic assumptions.....	152

	2.19.21 Operation Strategy Calculation	152
Tools	156	
	2.19.22 Introduction.....	156
	2.19.23 Generate ambient temperatures	156
	2.19.24 Copy energy conversion to Clipboard	157

3 Method of calculation in energyPRO 159

3.1 Method of energy calculation in energyPRO	159
3.1.1 The optimisation problem	159
3.1.2 Time series is a fundamental object in energyPRO	160
3.1.3 Splitting up the planning period (fixed tariffs)	163
3.1.4 Energy conversion units	164
3.1.5 Thermal storage and cold storage	166
3.1.6 The Operation strategy (example with Fixed tariffs – User defined)	166
3.1.7 Calculating a time period under restrictions	167
3.1.8 Planning of new productions follow Operation strategy	169
3.1.9 An example of planning optimal productions in energyPRO.....	170
3.2 Method of economy calculation in energyPRO	179
3.2.1 energyPRO calculates nominal payments	179
3.2.2 Net present value calculation.....	180
3.2.3 Internal rate of return	180
3.2.4 Payback time	181
3.3 Method of solar calculation in energyPRO	183
3.3.1 Definitions	183
3.3.2 External conditions	185
3.3.3 Radiation on solar collector or photovoltaic	185
3.3.4 Array shading.....	189
3.3.5 Solar Collector	193
3.3.6 Incidence angle modifier, Flat plate solar collector.....	194
3.3.7 Incidence angle modifier, Evacuated tube solar collector.....	195
3.3.8 Photovoltaic.....	196
3.4 Method of wind farm calculation in energyPRO.....	198
3.4.1 Definitions	198
3.4.2 Mathematical description	198

4 Functions in energyPRO 200

4.1 Introduction	200
4.2 Functions used in all (or more) formula fields	201
4.3 Functions used only in Time series functions	203
4.4 Functions used only in Production units load curves	204
4.5 Functions used only in Revenues and Operational Expenditures.....	210
4.5.1 Functions measuring on the system border	211
4.5.2 Functions measuring on energy conversion unit level	216
4.5.3 Other Functions	227
4.6 Functions used only in Taxation	231
4.7 Functions used only in Annual Key Figures	233

Appendices 239

A Import data from a spread sheet to a time series.....	239
B How to save as a .pdf file	242
C How to change the set-up in the graphic reports.....	243
D Interpretation of economy functions when calculating the operation strategy for a production unit.....	245
4.7.1 Electricity demand is present / Private wire / Geschlossenes verteilernetz. .	246

1 Introduction to energyPRO

1.1 Introduction

energyPRO is a complete modelling software package for combined techno-economic analysis and optimisation of both cogeneration and trigeneration projects as well as other types of complex energy projects with a combined supply of electricity and thermal energy (steam, hot water or cooling) from multiple different energy producing units.

energyPRO is typically used for techno-economic analysis of energy projects such as district heating cogeneration plants with gas engines combined with boilers and thermal storage, industrial cogeneration plants supplying both electricity, steam and hot water to a site, cogeneration plants with absorption chilling (trigeneration), biogas fuelled CHP plants with a biogas store, biomass cogeneration plants. Other types of projects, e.g. geothermal, solar collectors, photovoltaic or wind farms can also be analysed and detailed within the software. energyPRO can also be used for analysing hydro pumping stations, compressed air energy storage and other electricity storage projects.

energyPRO allows the daily optimization of the operation to be made against fixed tariffs for electricity or against spot market prices. The optimization is taking into account the limited sizes of thermal and fuel stores.

energyPRO provides the user with a detailed financial plan in a standard format accepted by international banks and funding institutions. This includes presentation of the operating results for the project, monthly cash flows, income statements (P&L), balance sheets and key investment figures such as NPV, IRR and payback time. The software enables the user to calculate and produce a report for the emissions (CO₂, NO_x, SO₂, etc.) by the proposed project.

1.2 Installation

Insert the energyPRO CD (or demo USB stick) or run the downloaded .msi-file and the installation process will install the energyPRO software in C:\Program files\emd\energyPRO4\ by default.

Follow all instructions on the screen. The default data path will be C:\energyPRO Data\ - **it is important to change this at installation if you prefer to have the data located somewhere else!**

The energyPRO CD (or demo USB stick) or the downloaded .msi-file contains the entire energyPRO package. In demo mode you cannot calculate, print or save a project. However, upon purchase of energyPRO modules, EMD International A/S will provide you with a license key opening the licensed modules.

1.3 License Conditions

The independent association Energi- og Miljødata holds all Intellectual Property Rights to the energyPRO software, which is continuously developed by EMD International A/S and distributed worldwide through a network of appointed agents. The manual and other documentation from the energyPRO software are copyrighted and all rights reserved.

Conditions of use: The licensee, who has paid for or by other means legally obtained the right to use the program, is entitled to activate and use a license.

Copyright: The licensee may under no circumstances copy, pass-on, sell or in any other way distribute the program or documentation associated with the program to third parties.

License: The licensee is only allowed to use a single license on one computer at the time, if the licensee has activated a license on two different computers belonging to the same user.

Additional Licenses: The name and address of the licensee, which is printed on all reports from the software, will be the same on each additional license supplied as on the first license supplied.

Duration-Termination: All user rights to the program are withdrawn in case the licensee does not respect the terms of payment in force at EMD International A/S.

Limitation of Liability: The software is provided on an "as is" basis without warranty of any kind. EMD International A/S does not warrant, guarantee or make any representations regarding the functionality of the software, any results obtained by the use of the software and any software support provided by EMD International A/S and their agencies/partners in terms of correctness, accuracy, reliability, usefulness, or otherwise. The licensee is solely responsible for the selection of the software, for the installation, use of, and results obtained from the software and software support received. Also excluded is any implied warranty by EMD International A/S, such as merchantability, non-infringement and fitness for a particular purpose.

1.4 Service and Updates

A valid service agreement with EMD means that the user gets access to the following services:

- Free e-mail or telephone hotline service covering advice and guidance regarding the use of the software.
- The latest version of the software.
- Download access to online data from the EMD-server.

The user pays an annual service fee of 20% of the actual list price for modules covered by his License Agreement.

Software updates are not issued at regular intervals, but typically twice a year. It is possible to download improvements and updates from our website www.emd.dk. It is possible to let energyPRO automatically check for updates on program start-up. The first time energyPRO is started, the user will be asked whether or not energyPRO automatically should check for newer versions online. This can later be changed in the Help menu by clicking “Automatically check for updates”.

For users without a service agreement, or who have cancelled a previous agreement, any future software update charge will be calculated based on the date service expired on the license.

1.5 License activation

To work with energyPRO you need to activate your license. When buying energyPRO you will receive a license file needed for the activation.

The activation process in energyPRO is as follows.

Start energyPRO and choose the “License activation” in the Help menu.

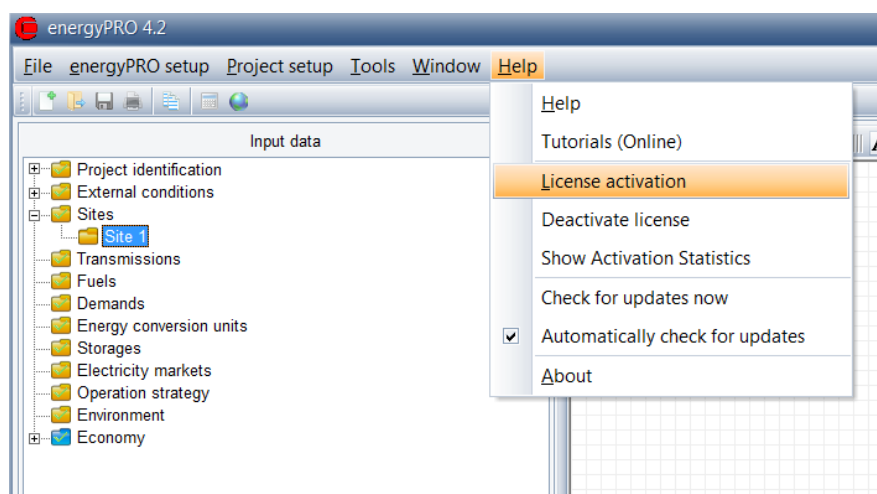

Figure 1.1: Accessing license activation item

The below window will appear and guide you through the registration.

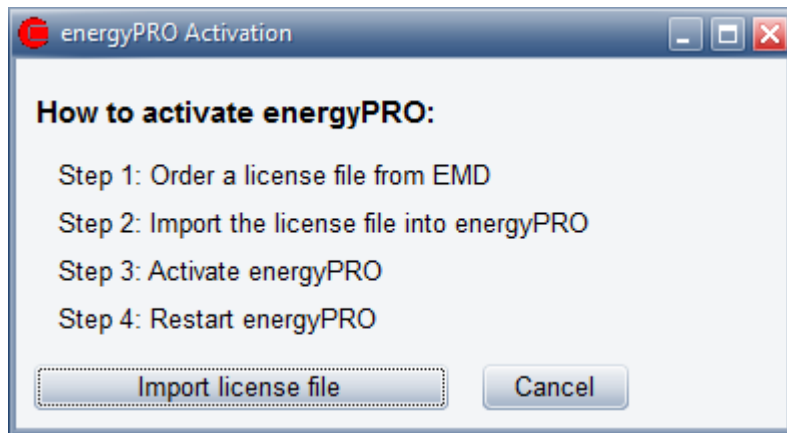

Figure 1.2: The 4 steps of registration and activation

“Import licence file” invokes an open file dialog, where you are asked to select the license file. The name of the file is: **energyPROx.x.erf** (where x.x is the version number). If you have saved the file elsewhere, just browse to find and open it. Click the “Open” button to import.

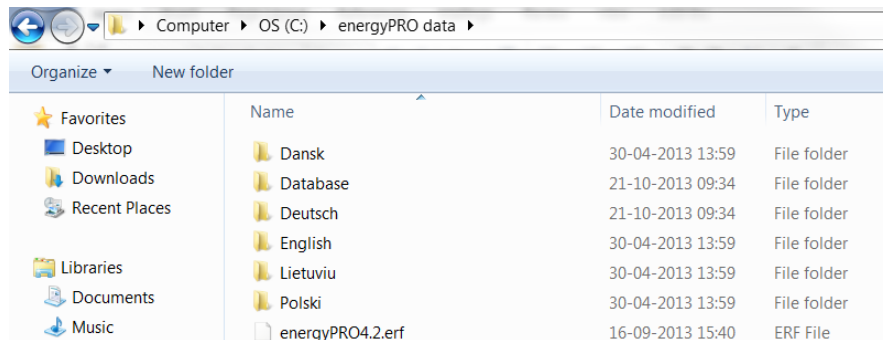

Figure 1.3: Open the energyPRO registration file

Next, the End user license agreement must be accepted:

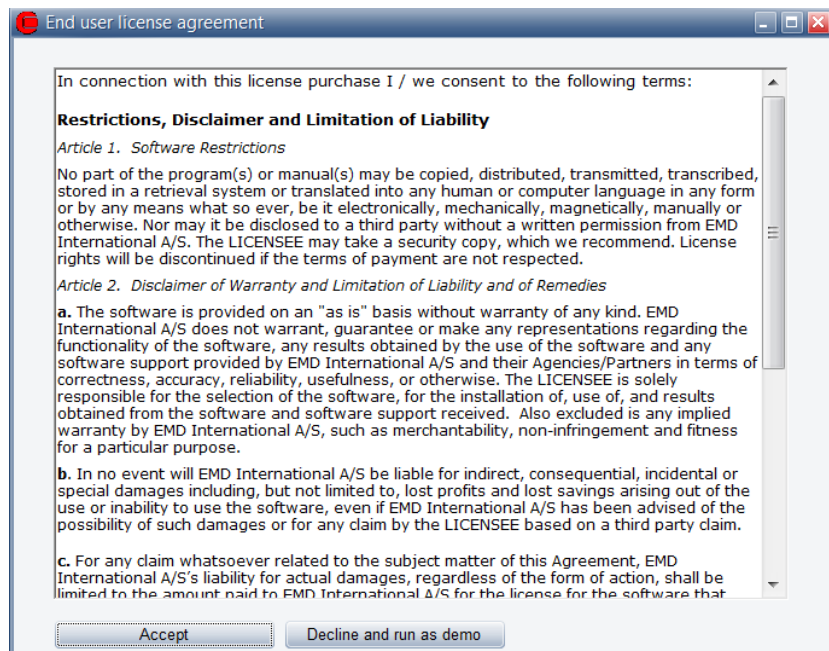

Figure 1.4: Accept End user license agreement

Each user is identified by email address and each user is allowed two installations, for example an office and a home computer or similar. In order to register, the user must go through the activation procedure.

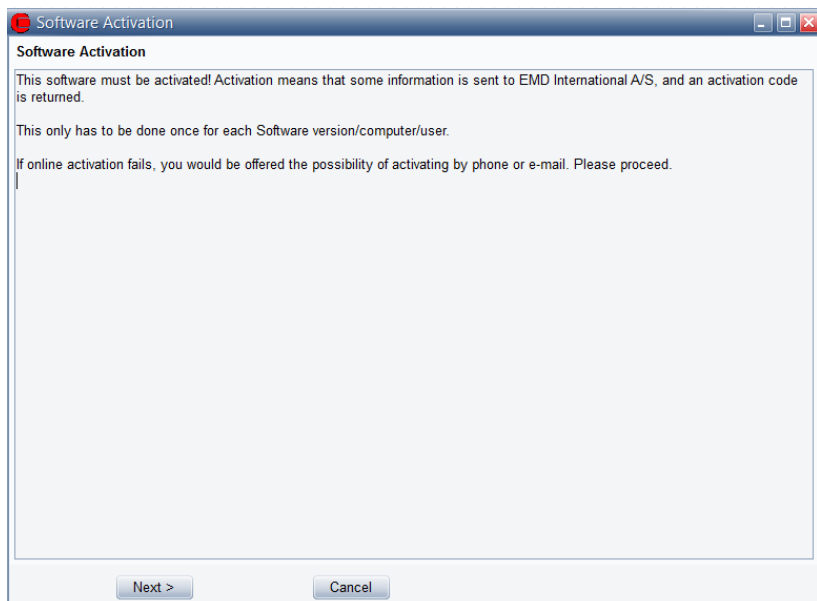

Figure 1.5: Software Activation

Press Next to continue the registration process.

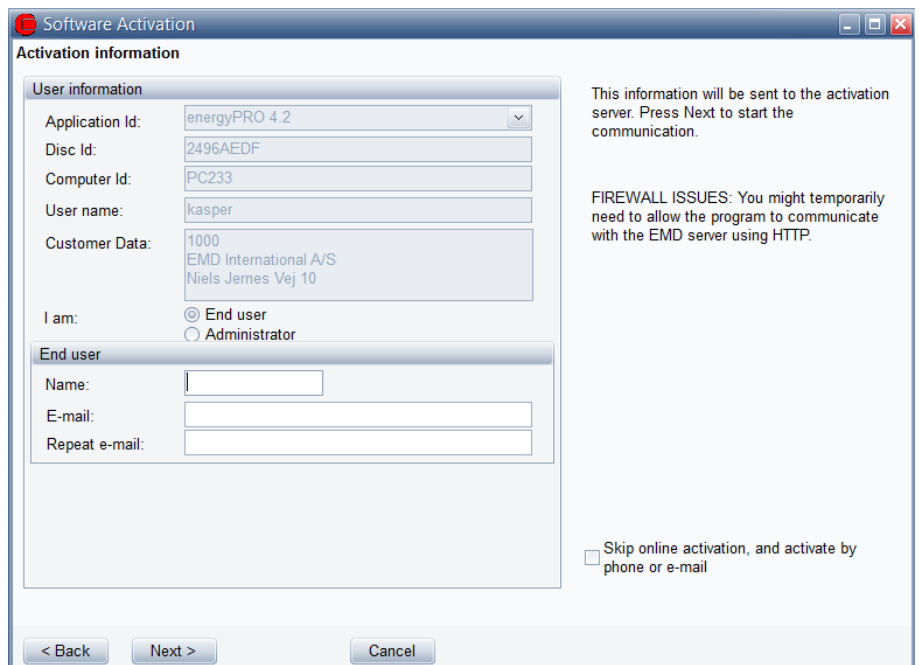

Figure 1.6: Activation information

On this screen the data to be sent to the activation server is displayed. The faded texts are read by the software (computer ID, user name etc.).

If you are the end-user you fill in your name and email address. A license holder is allowed as many email addresses as you have licenses and each email address can be used twice.

If you are the administrator you can additionally add your own email address. That will make the activation code come to you instead of the end-user, but the administrator address does not count to the allowed number of licenses.

The “Skip online activation...” option is available for users, who do not want to send information via the internet, using FTP. Check this to activate by e-mail or phone.

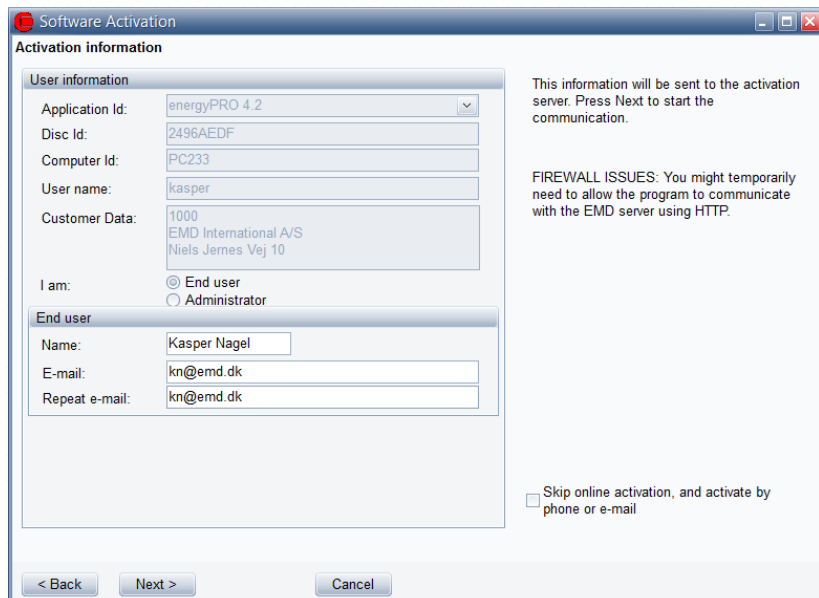

The screenshot shows the 'Software Activation' window with the 'Activation information' tab selected. The 'User information' section contains the following fields: Application Id (energyPRO 4.2), Disc Id (2496AEDF), Computer Id (PC233), User name (kasper), and Customer Data (1000, EMD International A/S, Niels Jernes Vej 10). The 'I am' section has radio buttons for 'End user' (selected) and 'Administrator'. The 'End user' section has fields for Name (Kasper Nagel), E-mail (kn@emd.dk), and Repeat e-mail (kn@emd.dk). On the right, there is a note: 'This information will be sent to the activation server. Press Next to start the communication.' and a warning: 'FIREWALL ISSUES: You might temporarily need to allow the program to communicate with the EMD server using HTTP.' At the bottom right, there is a checkbox for 'Skip online activation, and activate by phone or e-mail' which is currently unchecked. Navigation buttons '< Back', 'Next >', and 'Cancel' are at the bottom.

Figure 1.7: Activation information with end-user information

It is possible to buy a different number of licenses for each module.

If all modules bought by the user should be activated select “Activate all modules”.

If instead only a selection of modules should be activated then select “Activate individual modules”.

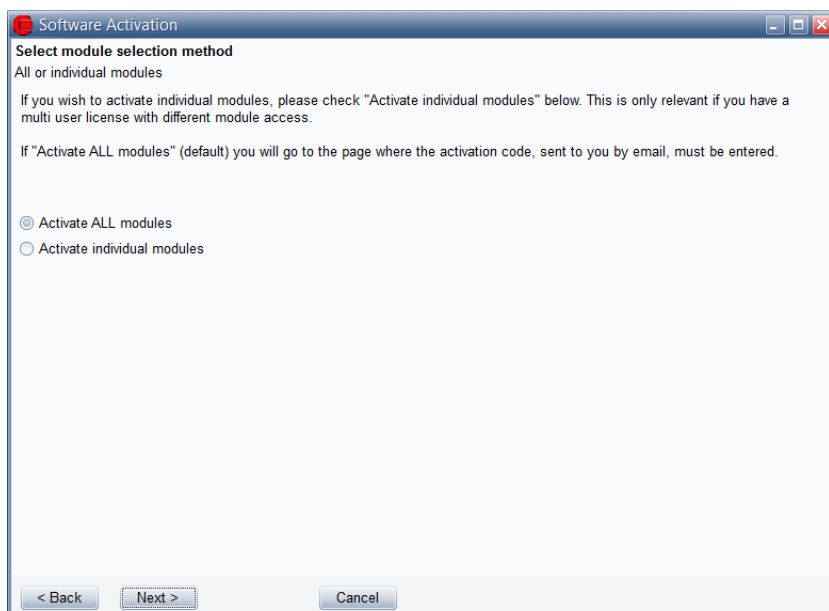

The screenshot shows the 'Software Activation' window with the 'Select module selection method' screen. The title is 'Select module selection method' and the subtitle is 'All or individual modules'. The text reads: 'If you wish to activate individual modules, please check "Activate individual modules" below. This is only relevant if you have a multi user license with different module access.' and 'If "Activate ALL modules" (default) you will go to the page where the activation code, sent to you by email, must be entered.' There are two radio buttons: 'Activate ALL modules' (selected) and 'Activate individual modules'. Navigation buttons '< Back', 'Next >', and 'Cancel' are at the bottom.

Figure 1.8: Select module selection method

If “Activate individual modules” was selected then you must point out the ones to activate. The list will show you all your available modules. If the module you wish to register is not in the list, then you do not have a valid license for it and you may contact EMD. By showing the activation statistics you can see who are currently using the licenses in the company.

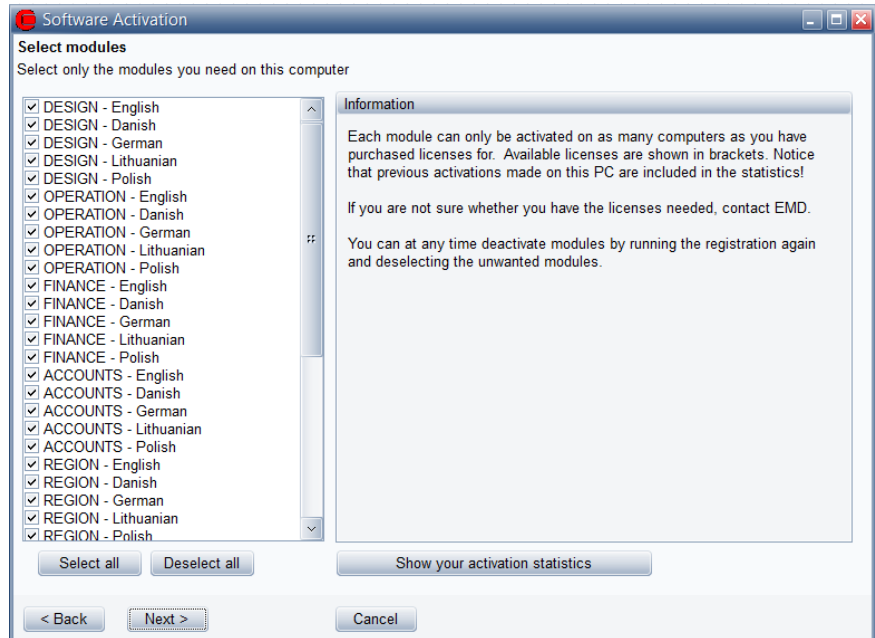

Figure 1.9: Select modules

Next step is to enter the activation code. At this stage you will have received an activation code in your email inbox. The code will be sent to the email address you typed in previously.



Figure 1.10: Enter activation code

Your license has now been successfully activated.

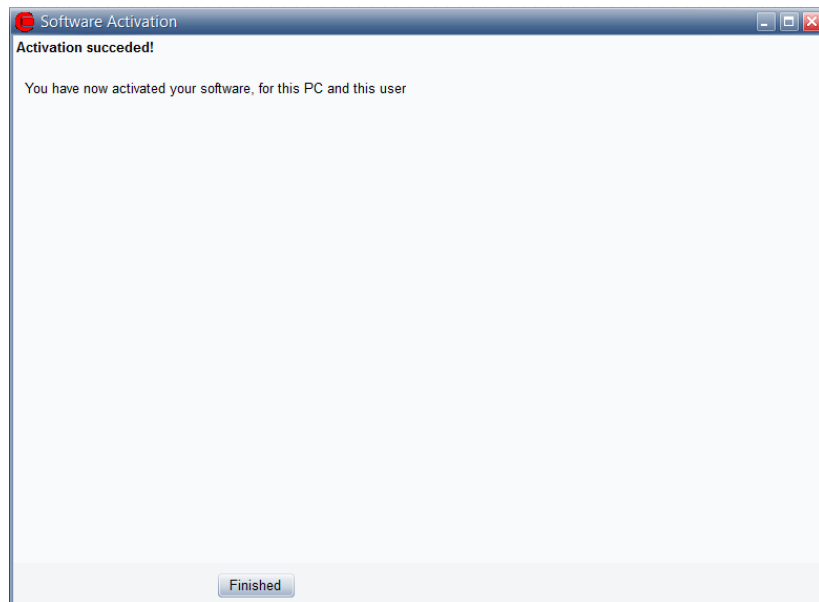

Figure 1.11: Activation succeeded

The activation process is concluded by showing you the “About” window for energyPRO on this computer. Here you can see the license information for your organization. This is the information included on all printouts made with energyPRO. You can also see your current version of energyPRO. If you suspect your version not to be current, and you do not let energyPRO automatically check for updates, you can visit the energyPRO download page and check if newer versions are available.

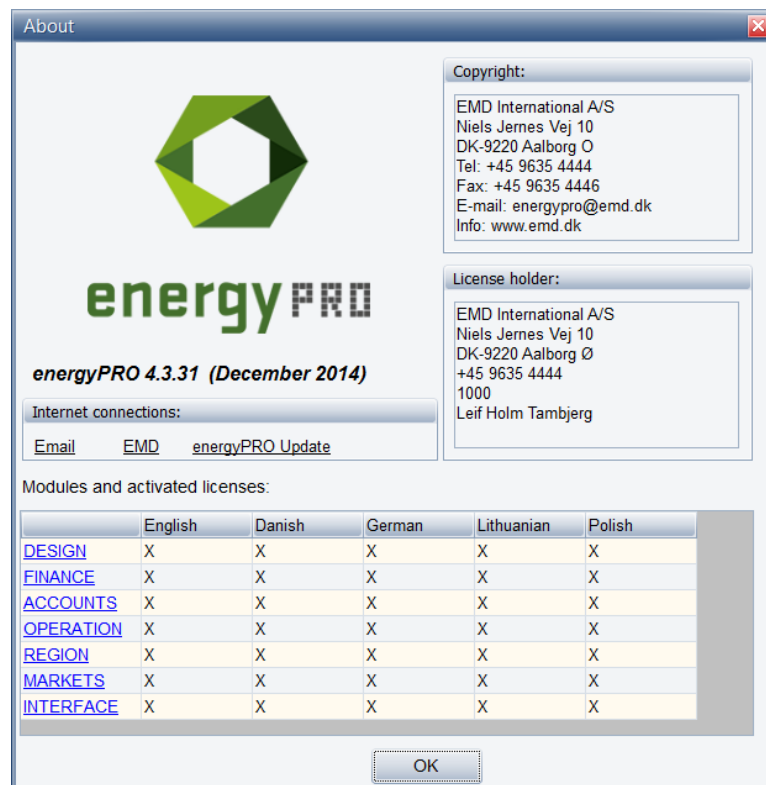
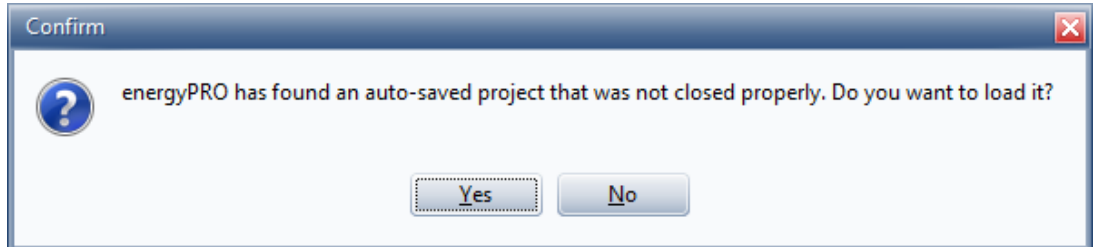

Figure 1.12: About box with registration information

Press Restart. When having restarted the program, the registration and activation will be accepted.

1.6 Auto save and recovery

EnergyPRO automatically saves a copy of the project file every second minute. If energyPRO closes down unexpected or you are forced to close it, you will meet this message next time you open energyPRO:



1.7 The energyPRO desktop

The energyPRO desktop is divided into three main sections as shown in Figure 1.13. These are:

- The Input data structure
- The Editing window
- The Report structure

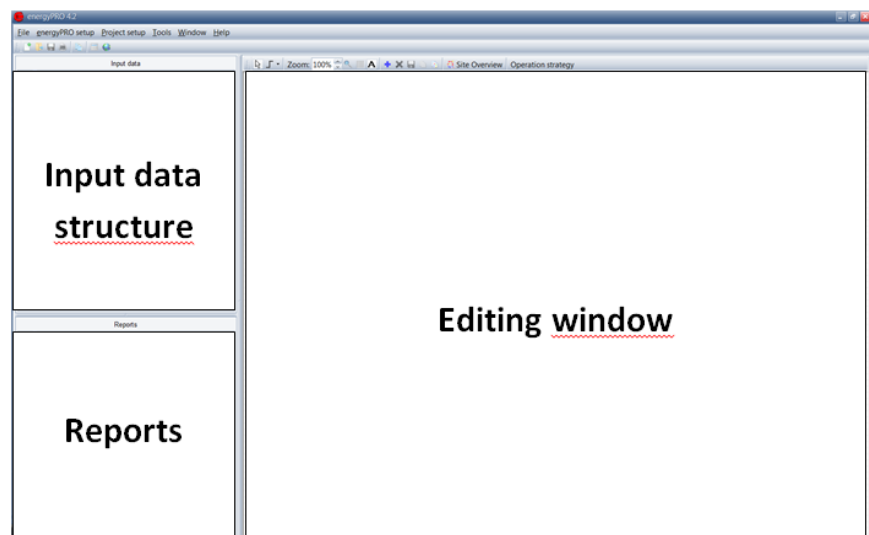

Figure 1.13: The three main sections of the energyPRO desktop

1.7.1 Input data structure

The Input data structure has functionalities much like the classic Windows

The Input data structure is arranged in a folder structure as known from the classic Windows explorer. The functionality attached to the folders is aimed to be as similar as practically possible to the Windows explorer.

explorer, and serves as the energyPRO desktop navigator.

Furthermore, the input data structure serves as the energyPRO desktop navigator.

By right clicking the mouse on any folder in the input data structure, the available folder specific options are shown.

In Figure 1.14 is shown the main input data folder structure for "Input data". The folders shown in this figure are the standard root folders found in all energyPRO projects, and are always present when energyPRO is started. This is the starting point for all energyPRO projects

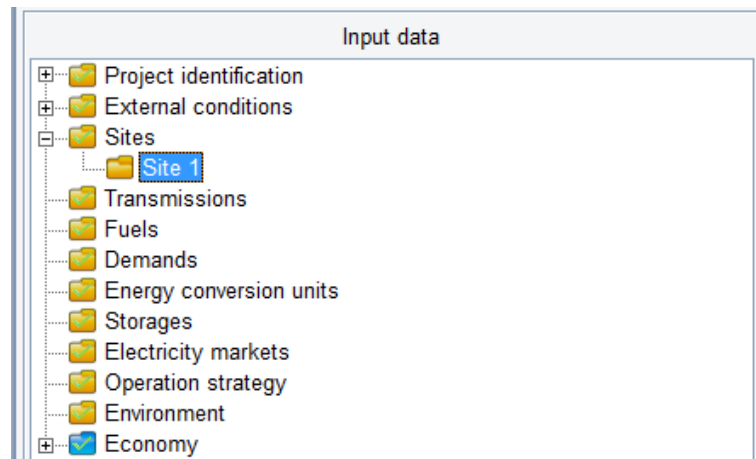





Figure 1.14: Input-data. The main input data folder-structure

Each folder (and subfolder) in this structure corresponds to an editing window.

Folder icons/data consistency check

Folder icons are used for indicating the integrity of the data in the project

Folder icons are used for indicating the integrity of the data in the project. Folders with yellow background indicate technical data/reports and blue background indicates economy data or reports.

-  Input data is OK
-  Error in input data
-  Selected folder
-  Unmarked folder (data only checked before calculation)

energyPRO automatically runs consistency checks on the data in the actual project (if not disabled in the project identification window). Errors are indicated by red crosses on folders.

If error(s) are present in projects, more information about the error(s) can be obtained by pressing the red crossed button in the toolbar.



Figure 1.15: Access to error list through toolbar.

Start your energyPRO experience by studying the standard examples delivered with energyPRO

Right click the mouse on the folders and discover the options

New energyPRO users are recommended to start their energyPRO experience by loading some of the project examples delivered with energyPRO. These project files are loaded by choosing the “Open” option in the “File” menu. Selecting one of the files found in the “Project examples” folder. Often the easiest way to create a new energyPRO project is to modify an existing project with similar traits.

When constructing a project some of the root folders are supplemented with subfolders, containing specific information defining for instance time series containing ambient temperatures, demands, fuels or production units. It is possible to add subfolders to the root folders: External Conditions, Fuels, Demands and Energy Units. Hereto comes in “Economy”, the option to add subfolders to the second level folders in “Economy”.

How to add, load, save, and rename subfolders.

By right clicking the mouse, while placed on a folder, a small frame will become visible. In this frame, the options attached to this specific folder are shown. The content of the frame is context-sensitive. An example of such a frame is shown in the following Figure 1.16, where the mouse is right clicked on “Energy conversion units”. In this case the options are to add a production unit, a heat rejection unit or to load one of these from a library if data is available.

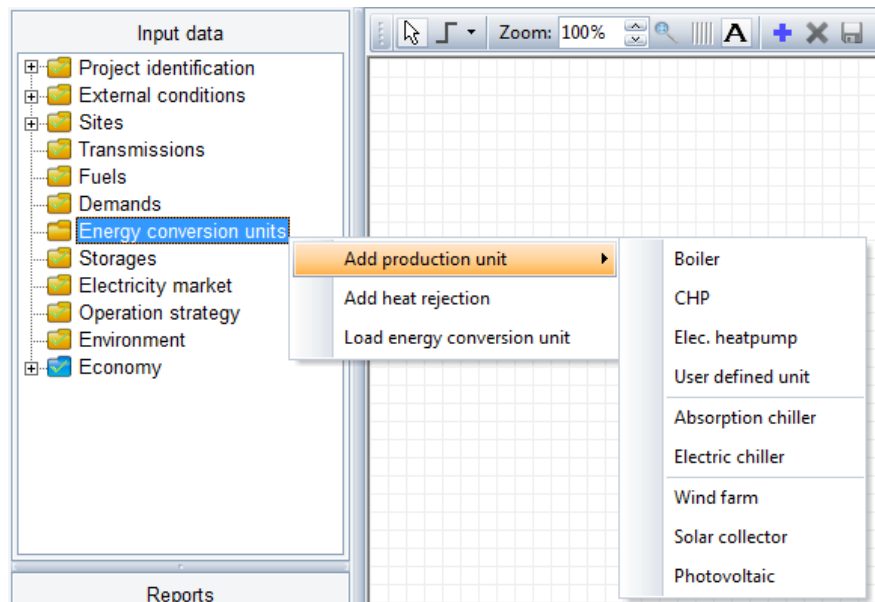

Figure 1.16: Right-clicking the mouse on a folder to reveal the folder options.

The typical options supplementing the “add” and “load” options are options to “save”, “copy” and “rename” the folder.

energyPRO projects are constructed by entering all input data folders and then filling in the needed information in the corresponding editing windows and adding new folders.

1.7.2 The editing windows

The editing windows are highly context sensitive depending on the type of input data. Below is a very brief description of the content of the editing windows that correspond the Input data structure presented in Figure 1.14. Detailed descriptions of the specific editing windows are found in chapter 2.

Project Identification

This is the place to make a description of the project in text and to define which type of projecting there are in question: DESIGN, FINANCE, ACCOUNT or OPERATION. The choice of the option selected will especially change the content of the Economy and Report folders.

- The DESIGN module is selected for one-year calculations, with emphasis on energy conversion and operation payments.
- The FINANCE module is selected for investment analysis. This add Investments and Financing to the DESIGN and includes calculations running over more than one year
- The ACCOUNT module adds the calculation of income statements and balance sheets to the FINANCE module. Add depreciation and taxation to the calculation input.
- The OPERATION module is selected for optimizing the operation in a short period. The content is almost like in the DESIGN module, but with a few more settings.

The REGION module is a supplementary module enabling the possibility of having geographically distributed productions on more sites in the same model. The REGION module might be used for regional energy planning models, and can be used in combination with any of the four types of projecting.

The MARKETS module is a supplementary module enabling the possibility of having more markets. This makes it possible to e.g. sell electricity production on spot market or fixed tariffs and purchase of electricity for your electricity demand on a flat rate.

Or you can have more CHP sites connected in REGION, where the different sites are connected to different markets.

With INTERFACE you will be able to perform energyPRO calculations where the planning period is one year or longer. You will not be able to make calculations with less than one year planning period. This is to avoid misuse of INTERFACE to daily planning in an energyTRADE manner. In order to make short term calculations with INTERFACE, you will need an energyTRADE license.

External conditions

The root folder contains the information about the planning period. It is possible to add folders containing the following types of sub data to the external conditions root folder:

- Time series
- Time series functions
- Indexes

Typical uses for Time series and time series functions are descriptions of electricity market prices, fluctuations of demands and the load curves of the energy units. Indexes are used for describing the development of energy demands over years.

Sites

This folder contains all the sites in the project. A site is defined as a location that contains demands, energy units and storages and can exchange energy with other sites via transmissions. The root folder shows a graphical overview of the different sites and transmissions between them. The sub folders show the graphical overview of a single site.

All energyPRO projects will contain at least one site and users that have the REGION module are able to add more sites and thereby model regional projects.

Transmissions

The Transmissions folder contains all the transmissions between the sites. A transmission in energyPRO is used to connect two sites so that they can exchange energy. A transmission has the following attributes:

- Start and end site
- Transmission in both directions or not
- Energy type, which in the current version can be Heat, Process Heat and Cooling
- Capacity and loss

Fuels

Add subfolders to the fuels root to describe the fuels used in your project. Example could be “Natural gas”, “Biogas”, “Coal” etc. It is optional to define a fuel store and describe that only a restricted amount of a fuel is available.

Demands

It is possible to define four types of demands.

- Heat demands
- Process heat demands
- Electricity demands
- Cooling demands

A demand is specified either by an annual amount of energy and a distribution or by a time series. If for instance a demand is degree-day dependent, a time series folder with ambient temperatures must be

placed in “External conditions” and selected when describing yearly variations in the demand.

There are several options to modify the distribution of a demand during a day, week, month or year.

Energy conversion units

There are two types of energy conversion units in energyPRO. These are:

- Production units
- Heat rejection

The production units consist of nine predefined types of units of which one is a user defined type described by load curve(s) and three renewable technologies described with individual editing windows. The Load curve described units are:

- Boiler
- CHP-unit (Combined Heat and Power)
- Electrical heat pump
- User defined unit
- Absorption cooler
- Electrical cooler

If the production unit type is consuming (or producing) fuel, a fuel defined in a “fuel” subfolder has to be selected.

The ability to convert energy is described with one or more load curves. Each load curve contains two or more loads, depending on the type of unit. The user-defined unit include all load types. The possible loads are:

- Fuel consumption
- Heat production
- Process heat production
- Process heat consumption
- Heat consumption
- Electric production
- Electric consumption
- Cooling production
- Fuel production

For advanced users there is a wide scope of options to describe the behaviour of energy units dependent on formulas, the actual production on other production units and time series specified in the “External condition”- folders.

The special treated renewable technologies without load curve description are:

- Wind farm

- Solar collector
- Photo voltaic

Storages

In this folder the different energy storage facilities are modelled. Three types of energy storages are available in energyPRO. These are:

- Thermal storage
- Electrical storage
- Cold storage

Note that fuel storages are modelled under each fuel.

Electricity market

In the Electricity market folder it is possible to define an electricity market. The options for electricity markets are:

- Fixed tariff
- Spot market

If the MARKETS module is not activated, it is only possible to add one electricity market. With the MARKETS module you can add any number of electricity markets to your model.

Operation strategy

The Operation strategy can be user defined or it can be auto calculated based on the payments set-up in the economy. The Operation strategy is basically a decision table used to describe the priority between energy production units in different tariff periods.

Environment

Emission types, such as CO₂, NO_x and SO₂, can be added in this folder if needed.

Economy

There are several types of input data for the economy calculations. The economic data (and the calculations based on these) are the main difference between the four types of projecting. The groups of economic data are:

- Revenues
- Operation expenditures
- Investment (FINANCE and ACCOUNT modules)
- Financing (FINANCE and ACCOUNT modules)
- Taxation (ACCOUNT module)
- Investment key figures (FINANCE and ACCOUNT modules)
- Annual key figures (ACCOUNT modules)

1.7.3 Reports

The range of reports is dependent on the selected type of projecting in “Project identification”. In the figure below is shown the reports available when the DESIGN-module is chosen. Clicking the folder invokes the desired report.

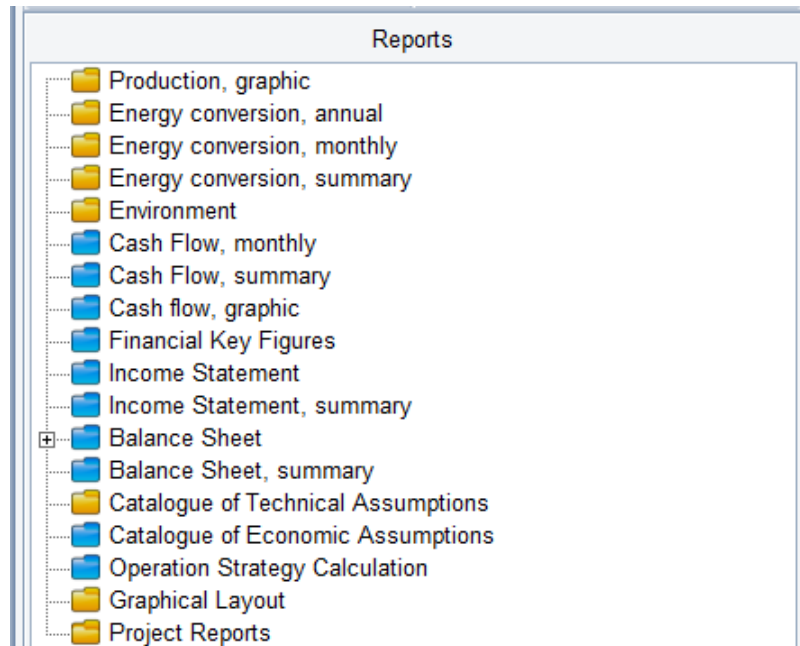

Figure 1.17: Available reports if DESIGN is chosen

Note that the “Operation Strategy Calculation” report is only available if the auto calculated operation strategy is chosen in the “Operation strategy” input window.

1.8 Graphical editing

The graphical editing option provides the user with an overview of the actual project and makes it easier to do the editing.

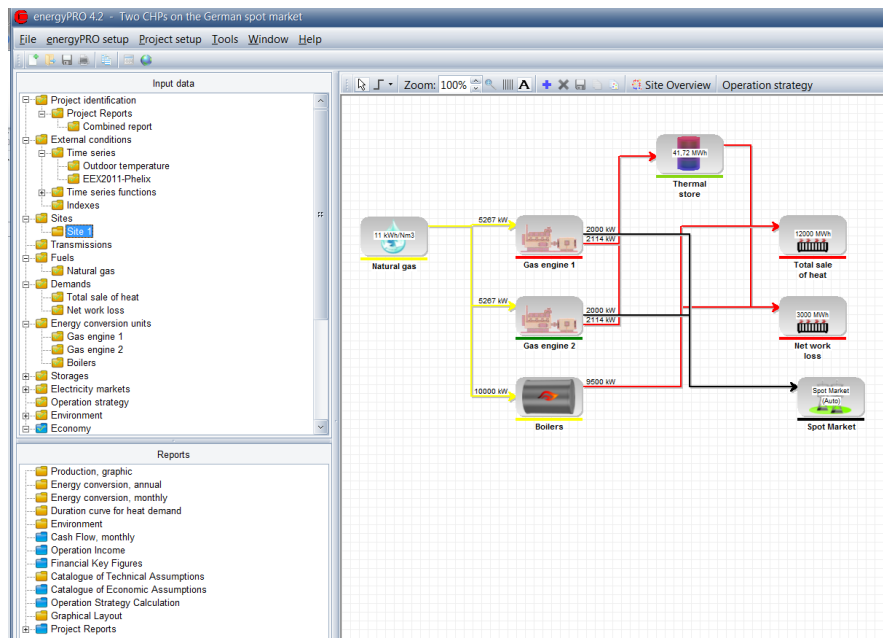

Figure 1.18: energyPRO in Graphical User Mode

1.8.1 What is included?

There are two different types of graphical overview, namely:

- The site overview which shows all the sites in the project and the transmissions between them. This view is only relevant in projects with more sites
- The graphical overview of a single site, which contains the following components:
 - Fuels
 - Demands
 - Energy Units
 - Electricity market
 - Transmission to other sites

This is, so to speak, the physical part of an energyPRO project. External conditions, Operation strategy, Environment and Economy are not included in this version of graphical editing.

1.8.2 What about the old way of doing things?

You can at any point change the settings to the classic user mode. In Setup – Options, you can switch between Graphical User Mode and Classic User Mode (see Figure 1.19). The setting is saved by energyPRO and is not depending on the given energyPRO project file.

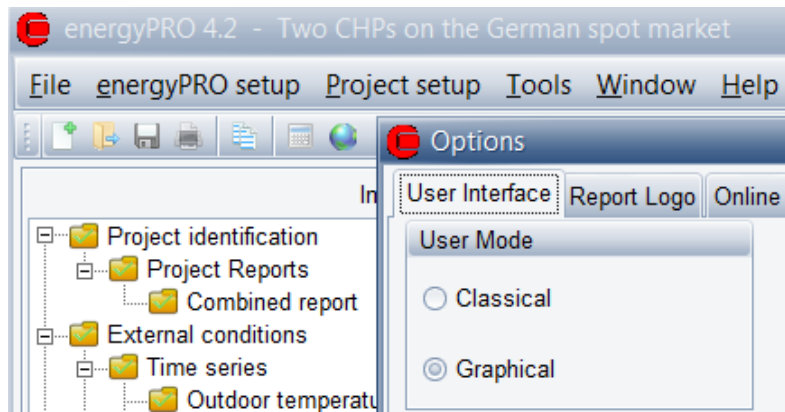

Figure 1.19: Switching between Graphical and Classic user mode

1.8.3 A better overview

The graphical user mode shows all the main figures at a glance. As shown in the screenshot below, you can see the heat value of the fuels, the full load capacities of the production units, the storage capacity, the annual demands and the electricity market type. At the same time you can see what fuel the production units use and if they have access to an energy storage facility or not.

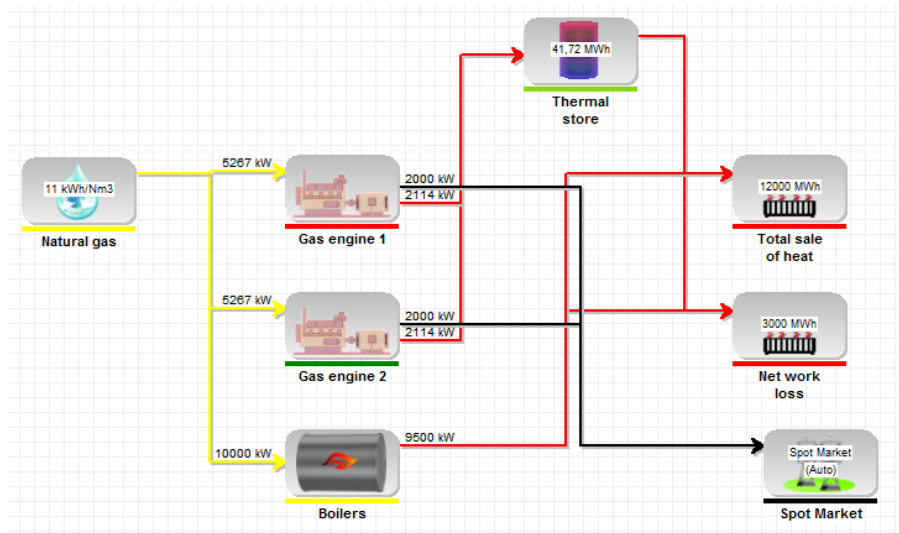

Figure 1.20: Graphical User Mode gives a better overview.

1.8.4 Adjusting View

Depending on the size of your screen it can be desirable to adjust the view of the graphic.

Zoom

In the toolbar above the graphic user interface it is possible to set the zoom-factor:

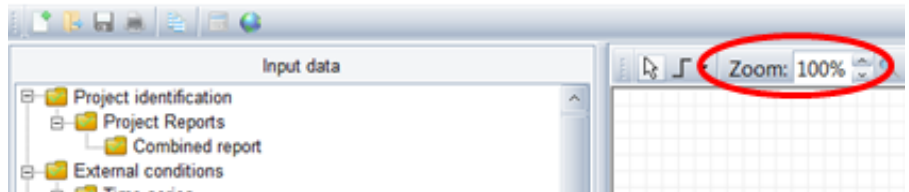

Figure 1.21: Setting zoom-factor

The up and down arrows increases and decreases the zoom-factor by 10%. A more detailed factor can be put in directly.

The magnifying glass icon adjusts the zoom-factor to fit the graphic window.

Arrange

When loading a projectfile saved in energyPRO 3, energyPRO 4 will automatically arrange the components and connections.

You are free to rearrange the components and connections. Figure 1.22 is rearranged by the user, with the same components as Figure 1.20.

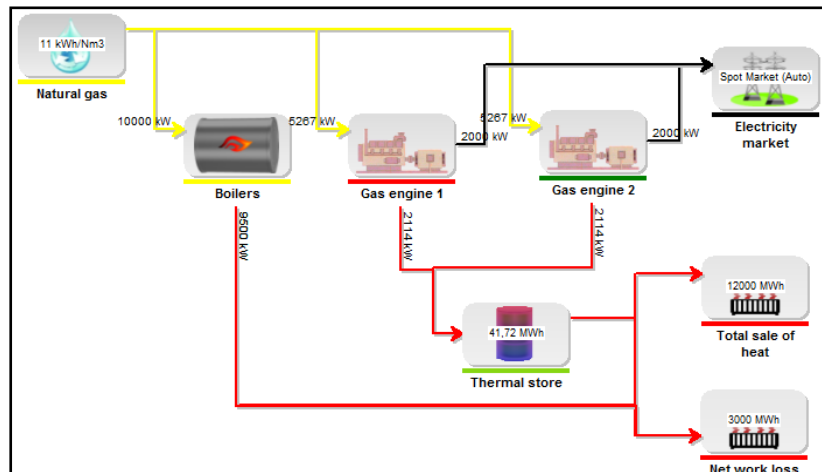

Figure 1.22: Rearranged graphic view

To rearrange, simply mark a component and move it as you like. If you mark a connection you will be able to drag any of the pointers to rearrange the connection, Figure 1.23.

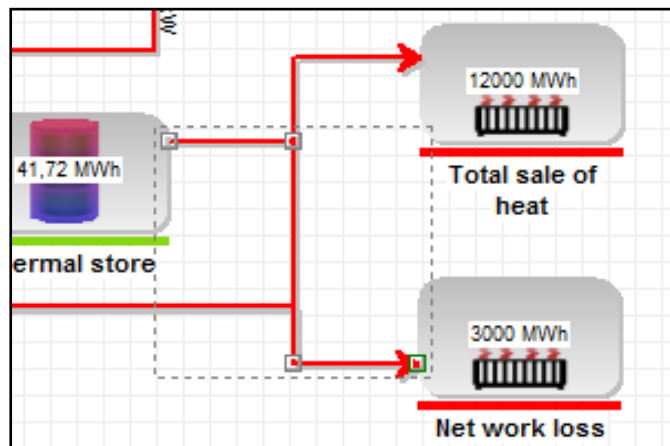

Figure 1.23: Marked connection

With the head or tail pointer the point of connection at the component can be changed, Figure 1.24.

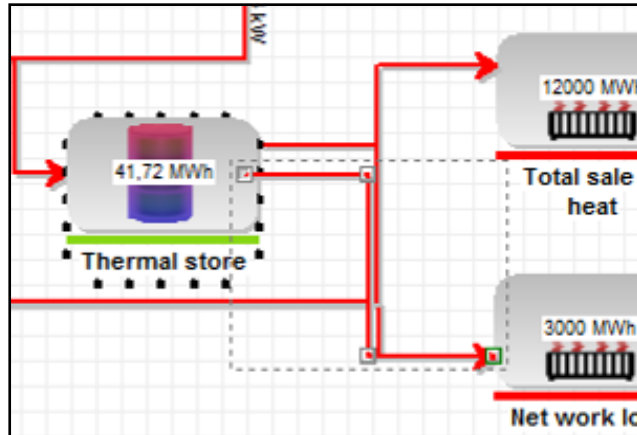

Figure 1.24: Moving connection point

If you regret the rearrangement, pressing the auto-arrange-button arranges the components and connections according to energyPRO default settings, Figure 1.25.



Figure 1.25: Auto-arrange-button

1.8.5 How to edit

Change values

If you need to change a value of a component, e.g. a production unit, you simply double-click the component or right click and select Open:

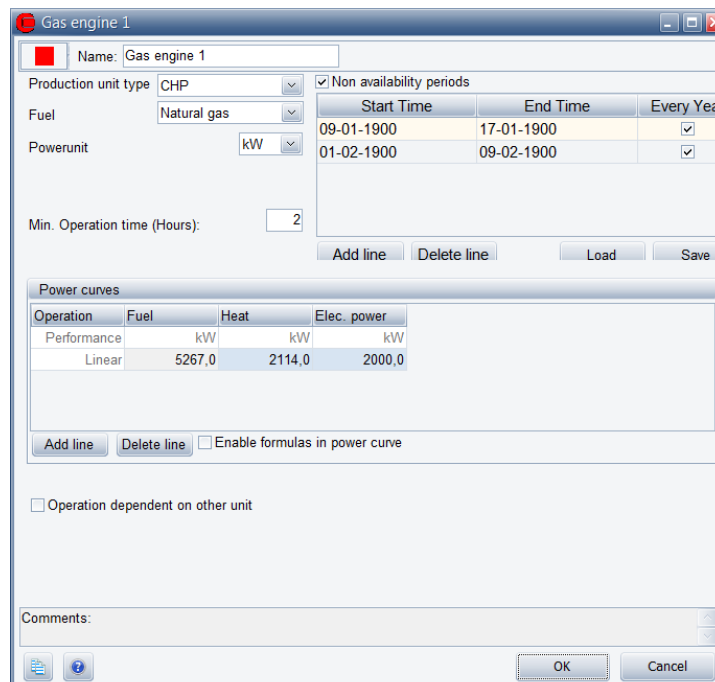

Figure 1.26: Edit-window, production unit

This window is very similar to the classic view. Additionally, you have the option of changing name of the component.

It is possible to cancel any changes by pressing Cancel, in other words your changes are not saved until you press OK.

1.8.6 Add Component

In the graphic user mode, you have two ways of adding a fuel, demand or energy unit. 1), click the blue plus-sign in the toolbar or 2), right-click on the background. In both cases you have the menu shown in Figure 1.27.

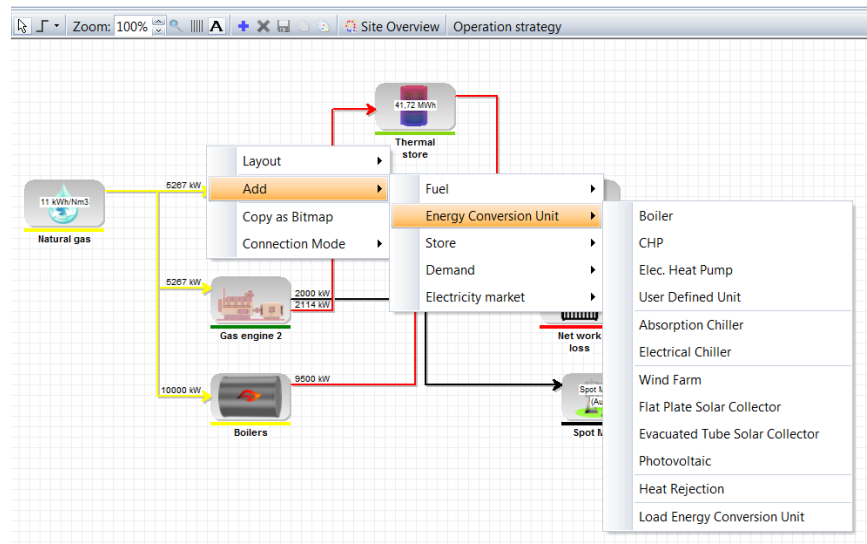

Figure 1.27: Adding a component

Visual Properties

The visual properties of a component are accessed by right-clicking and select Visual Properties, Figure 1.28.

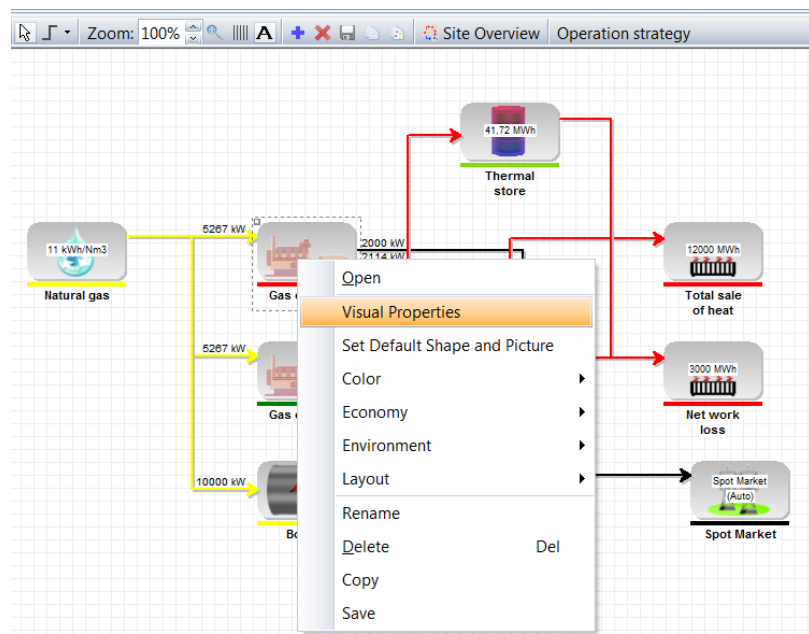

Figure 1.28: Access to Visual Properties

By selecting the Visual Properties the following screen appears, Figure 1.29.

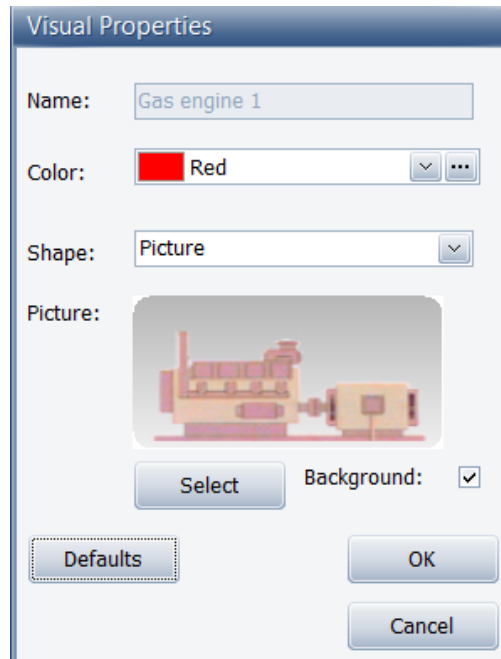

Figure 1.29: Visual Properties

The Color is used when representing the production unit in the Production, graphic report.

As shape you can choose between a rectangle, ellipse, diamond or picture. If choosing picture, you have access to select a picture. Defaults return the component to the energyPRO default setting.

In Select Picture (Figure 1.30) you can choose between a number of build-in pictures or you can add your own pictures.

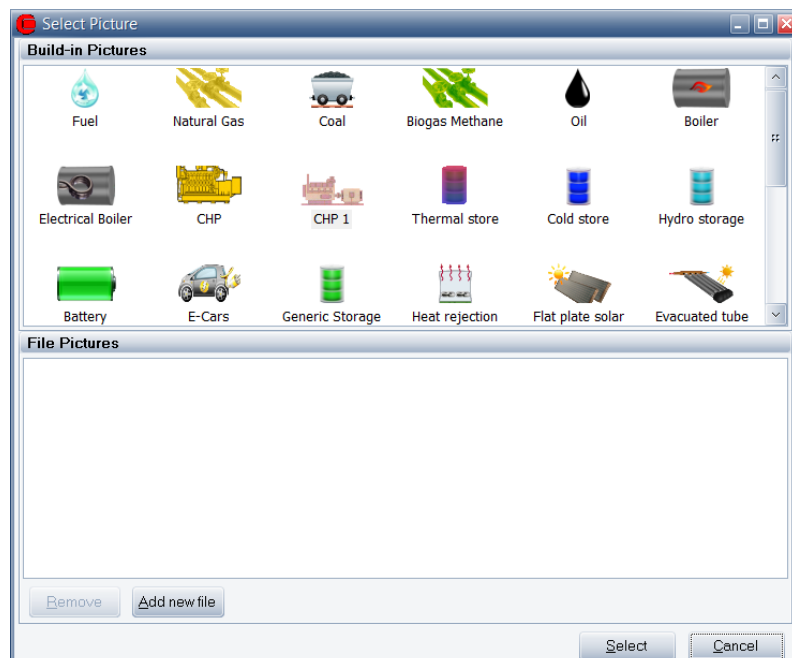

Figure 1.30: Select Picture

1.8.7 Connections

Let's say you want to change the fuel of a production unit. You can in the edit-window Figure 1.26 change the fuel in the drop-down menu or you can move the connection, Figure 1.31.

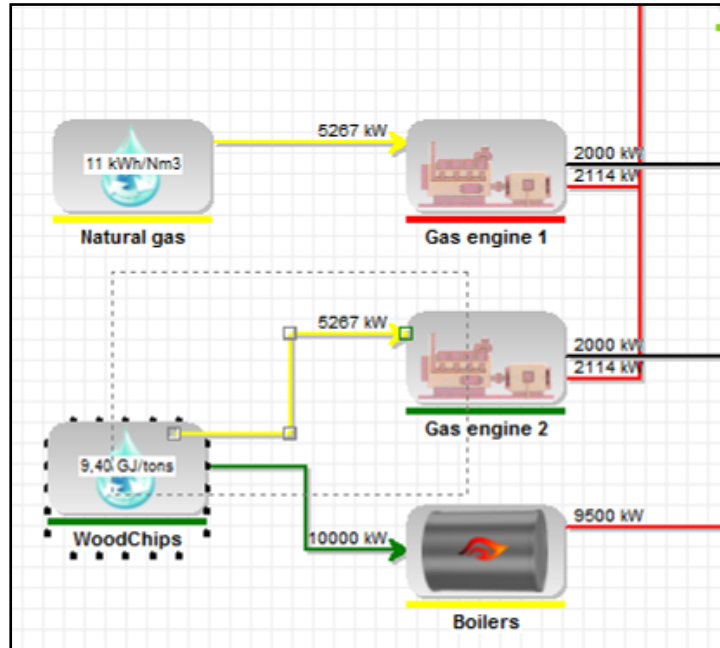

Figure 1.31: Change fuel by moving connection

Click on the connection between the fuel and the production unit, press on the node at the tail of the connection and move it to the wanted fuel. Finally, release the mouse button. The colour of the connection is changed to the colour of the wanted fuel, Figure 1.32.

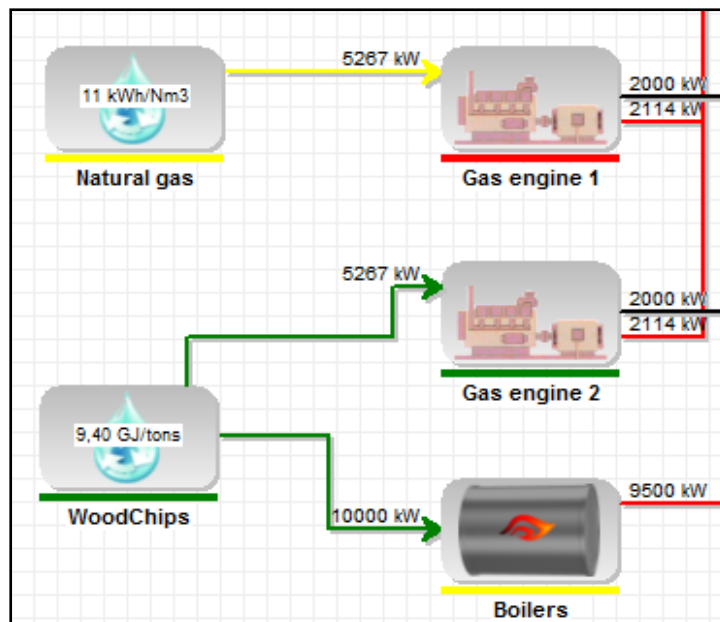

Figure 1.32: Gas engine 2 has changed fuel

Another example, if you want to change the setting of a production unit's access to the thermal store. In the classic user mode you set the

access in the operation strategy. In the graphical user mode you can also change the setting by moving a connection. In the example below you click the connection between Boilers and any of the heat demands and move the head of the connection to the thermal store, now all the production units have access to the store:

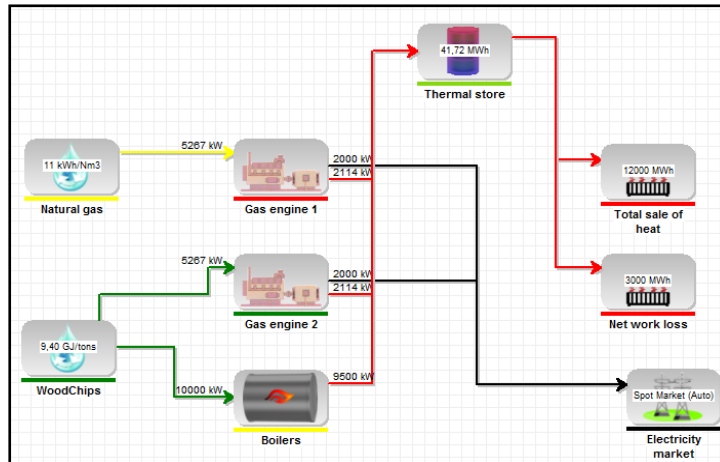

Figure 1.33: Boilers now have access to the thermal store

In some case it does not make sense to move or delete a connection. E.g., a production unit producing electricity has to have a connection to the electricity market. If you try to delete such a connection the following warning will appear, Figure 1.34:

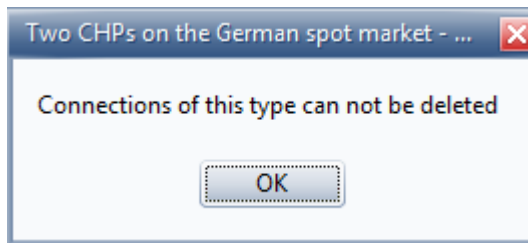

Figure 1.34: Warning, when trying to delete a connection

The colours of the connections cannot be set on the connections. The colour on a connection from a fuel to a production unit is the same as the colour of the fuel. The colour on a connection from a production unit to a demand is determined by the type of energy. Heat is red, cooling is blue, process heat is brown and electricity is black.

Three different lay-outs of a line

If you select a connection and right-click, you can choose between three different types of lines, Figure 1.35.

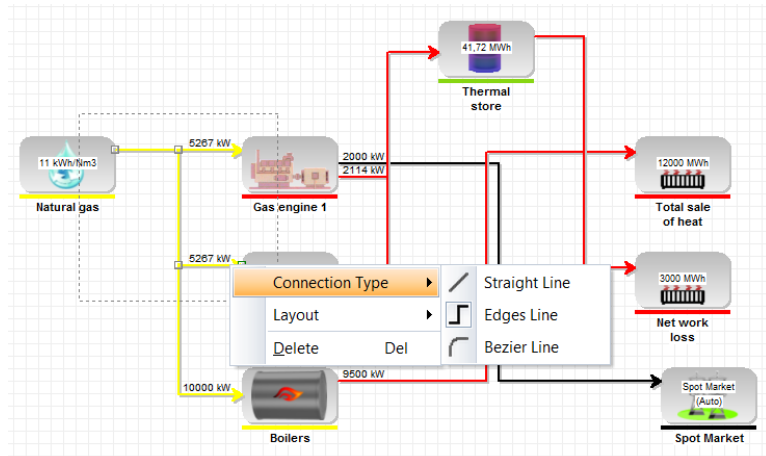

Figure 1.35: Different types of line

Figure 1.36 is an example of the three different types of lines.

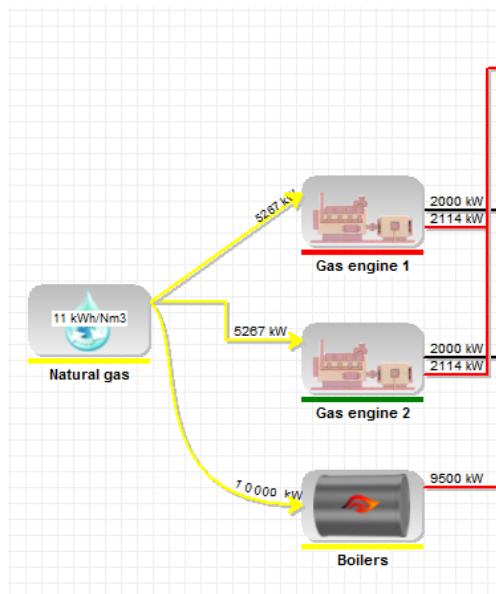

Figure 1.36: Example of different types of lines

The straight line can be modified by adding connector edge, Figure 1.37.

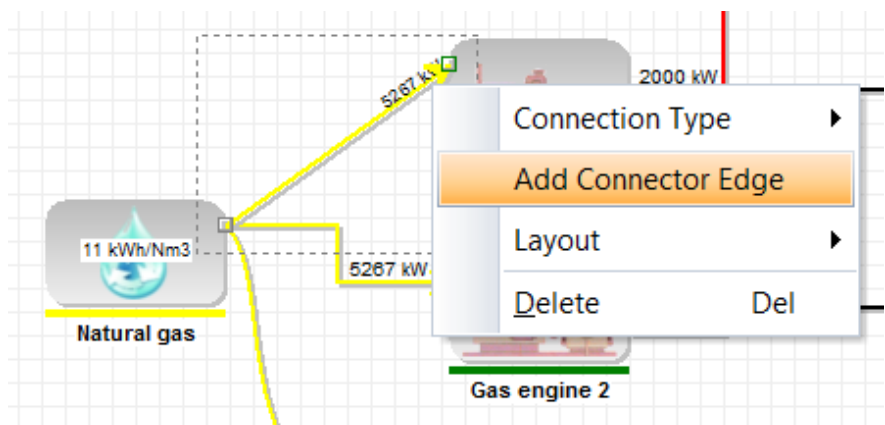

Figure 1.37: Add Connector Edge

Then, the connection can have whatever design you like, Figure 1.38.

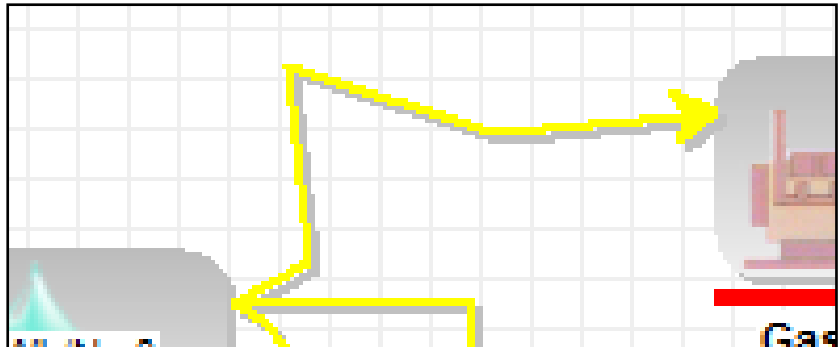

Figure 1.38: User designed connection line

1.9 Data-sets delivered with energyPRO

As a part of the energyPRO installation, a few country specific datasets are installed for each language. They are installed in the data structure shown in Figure 1.39. At present energyPRO is available in Danish, English, German, Lithuanian and Polish. Each of these countries has their own folder. The examples are country specific. Danish, English and German have five standard folders, which in English are:

- Energy units
- Fuels
- Other data
- Project examples
- Weather

Name	Date modified	Type	Size
2 MW wind turbine	19-03-2010 14:27	energyPRO4 Docu...	231 KB
500 kW photovoltaic	19-03-2010 14:28	energyPRO4 Docu...	348 KB
1000 m2 solar collectors	19-03-2010 14:31	energyPRO4 Docu...	358 KB
Two CHPs on fixed tariffs, NPV of 15 year...	31-03-2010 10:21	energyPRO4 Docu...	353 KB
Two CHPs on spot market incl. storage l...	21-09-2010 14:01	energyPRO4 Docu...	302 KB
Two CHPs on spot market	06-04-2010 13:06	energyPRO4 Docu...	289 KB
Two CHPs, Island mode	19-03-2010 14:16	energyPRO4 Docu...	301 KB
Two CHPs, Trigeneneration, Island mode	06-04-2010 14:55	energyPRO4 Docu...	331 KB

Figure 1.39: The default data structure of data delivered with energyPRO

Seeking data. Check eventually folders for other countries

Weather data for several European countries are found in the English weather folder

If you do not find, what you are looking for in your country specific standard folders you might find what you want in the corresponding folder for another country.

At present, the following folders might be of your interest.

In the folder **c:\energyPRO data\English\External conditions\Weather**, you will find weather data for several European countries. The data are mainly based on Test Reference Years.

A library of production units are found in the German energy units folder

A Fuel library is found in the German energy units folder

Your language in which you operate energyPRO decide the default standard folders

energyPRO remembers where data was loaded/saved last

In the German folder for energy units, **c:\energyPRO data\Deutsch\Energieanlagen**, you will find a library of energy production units.

In the German folder for fuels, **c:\energyPRO data\Deutsch\Brennstoffe**, you will find a library of fuels.

Along with the German folder is an extensive data bank with numerous time series, energy conversion units and project examples.

1.9.1 Finding data the first time

The first time you load data, energyPRO will automatically suggest that the data are found in the standard folders. If your computer is operated in an English language set-up, it uses the English standard folders and if in German language, the German standard folders etc.

This means that in an English language set-up it will look for projects in the “Projects examples”-folder and for fuels in the “Fuel”-folder and so on.

After the first load or save operation, energyPRO will remember in which folder data was loaded or saved, this will be the new default setting.

1.9.2 Danish Design Reference Year

Included in the Danish folder is the new Danish Design Reference Year, DRY:

c:\energyPRO data\Dansk\Ydre forudsætninger\Vejrdata\Design Reference Year

The Design Reference Year is made by the Danish Meteorological Institute (DMI).

The DRY is based on data from 2001 – 2010.

The following values are included (in parenthesis the Danish terms):

- Global solar radiation (Samlet solindstråling)
- Direct solar radiation (Direkte solindstråling)
- Diffuse solar radiation (Diffus solindstråling)
- Ambient temperature (Udetemperatur)
- Wind speed (vindhastighed)

Denmark is divided into 6 zones (5 zones when it comes to wind speed).

The zones for each type of data can be seen on the following maps.

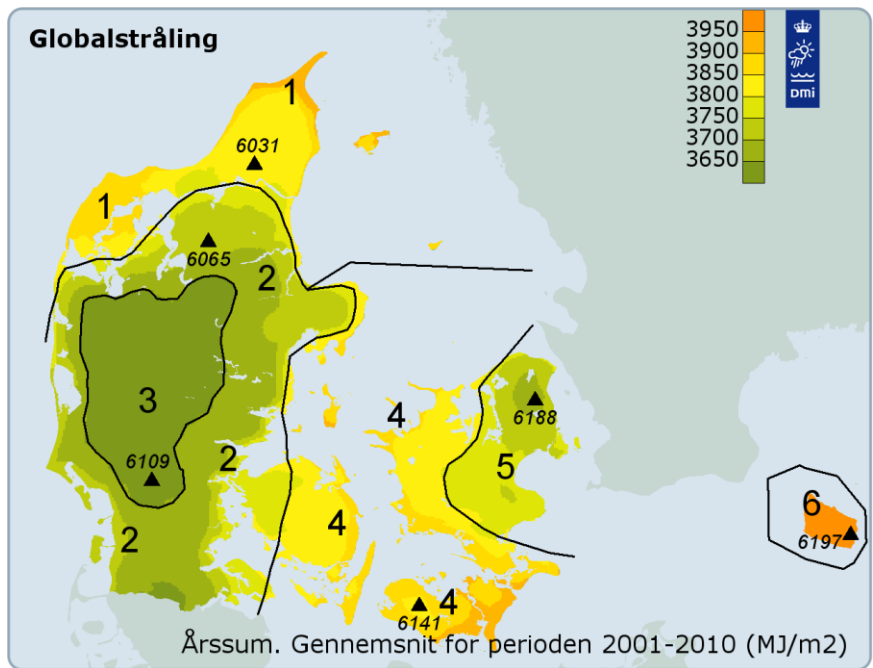

Figure 1.40: The DRY zones with global solar radiation

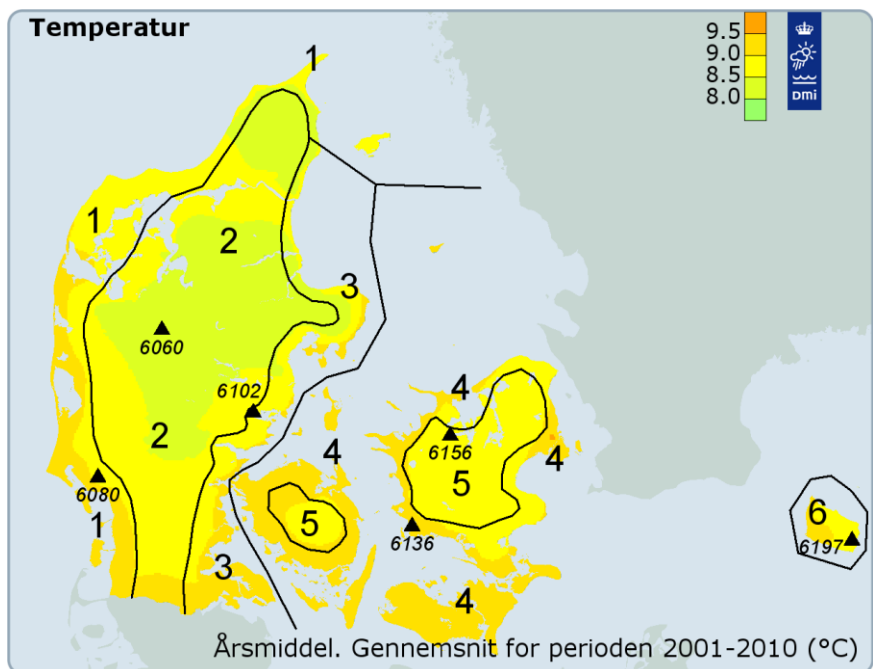

Figure 1.41: The DRY zones with ambient temperatures

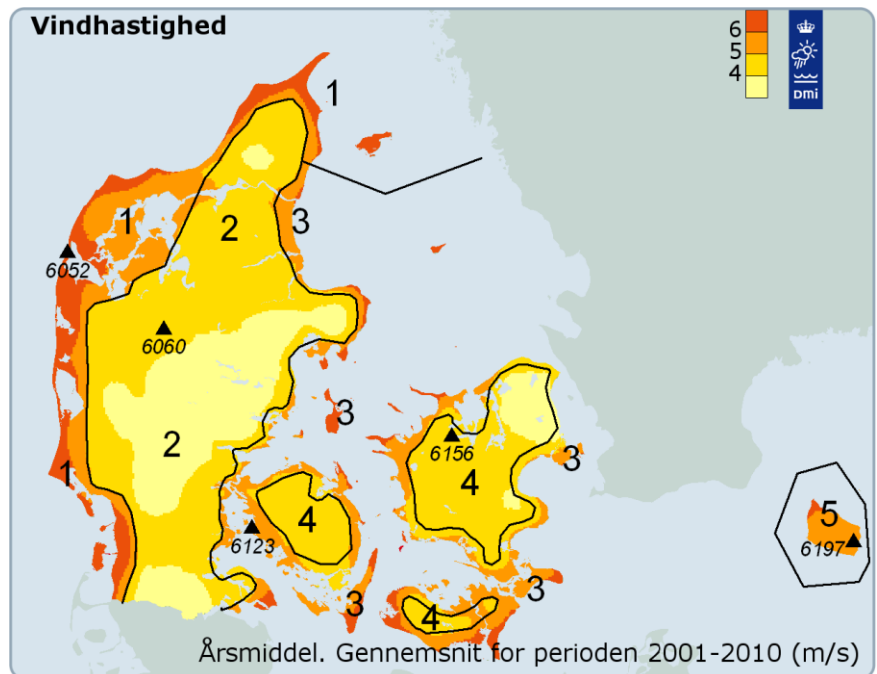

Figure 1.42: The DRY zones with wind speed

When selecting data for e.g. a solar collector the proper zone is selected for radiation and ambient temperature, respectively.

More information on the Danish Design Reference Year can be found at the Danish Meteorological Institute (DMI) website, dmi.dk. Direct link to documentation: <http://beta.dmi.dk/fileadmin/Rapporter/TR/tr12-17.pdf>

2 The energyPRO desktop in details

2.1 Introduction

In this chapter is a description of the Editing Windows used in energyPRO. After starting with information concerning some of the menu bar options, the description follows the order of the folders in the Input Data Structure.

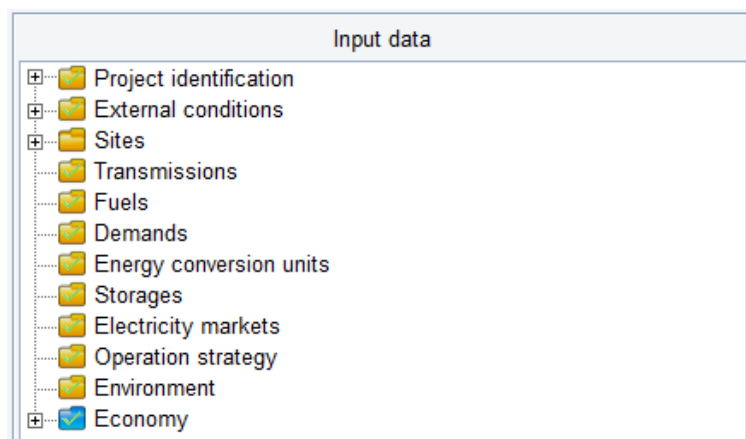

Figure 2.1: The Input-Data Structure

It is possible to use formulas in several of the Editing Windows. In this chapter you will only find a brief description of the functions to be used in these. A detailed description of these is found in the chapter, "Functions in energyPRO", which serves as a reference section for formulas used in energyPRO.

2.2 Menu bar

2.2.1 energyPRO setup

Demo mode

If you switch the program into DEMO-mode, you get the opportunity to evaluate the facilities in the modules, which you have not registered.

In DEMO-mode, you can change the input data, but you cannot save changes and the reports have the text “DEMO-version” written across the pages.

WARNING: If you have made changes to the project you are working with, remember to SAVE it before you switch into DEMO-mode. When first in DEMO-mode, you cannot save the project and you will lose all your changes!

Read only mode

If you switch the program into READ-ONLY-mode, you get the opportunity to print out results from energyPRO-project files you might have received from for instance a project partner without any restrictions.

In READ-ONLY-mode, it is not possible to change the project data, but there is access to calculate, view and print the reports available in the specific project.

Languages

Select one of the languages specified.

If you select a language that you have not licensed and registered, the program automatically turns into demo-mode.

The first time energyPRO is started, it will be operated in the same language as used by Windows (If the language is available for energyPRO - otherwise in English). If you want to change the language, choose Language in the main menu, select the wanted language and restart the program. If you do not have license to the selected language, energyPRO will start in DEMO-mode.

energyPRO is currently maintained in the following languages. English, German and Danish. Occasional updates in Polish and Lithuanian.

energyPRO is currently maintained in the following languages; English, German, Danish with occasional updates in Polish and Lithuanian.

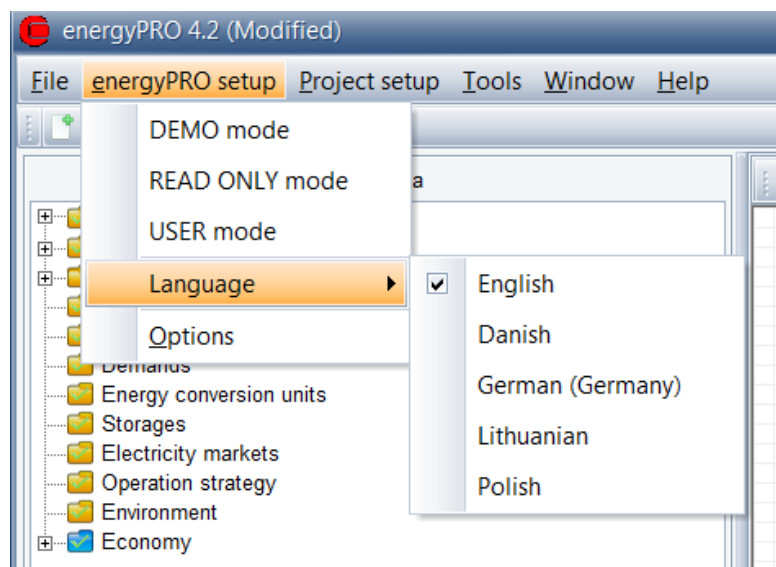

Figure 2.2: How to change language

Options

User Interface

The “User Interface” consists of three boxes.

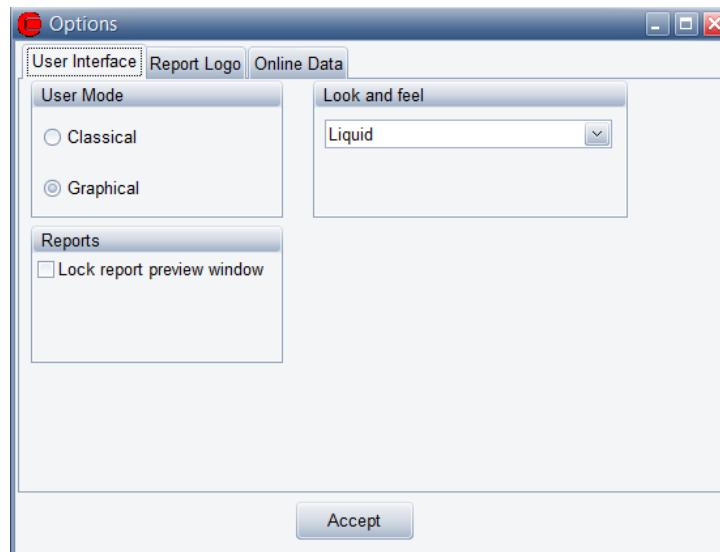

Figure 2.3: User Interface

It is in the User Mode menu possible to change between Classical and Graphical User Mode.

In Reports you can enable Lock report preview window. By enabling this you can only see one report preview at the time.

In Look and feel it is possible to change between a number of skins, changing the appearance of energyPRO. Liquid is standard.

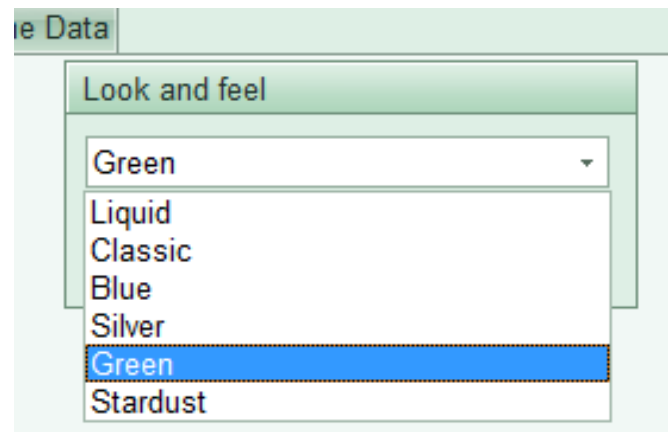

Figure 2.4 :Look and feel

Report Logo

In this menu it is possible to setup a company logo to be used in all the energyPRO reports. The logo will appear in the top right corner of each report as shown in Figure 2.5.

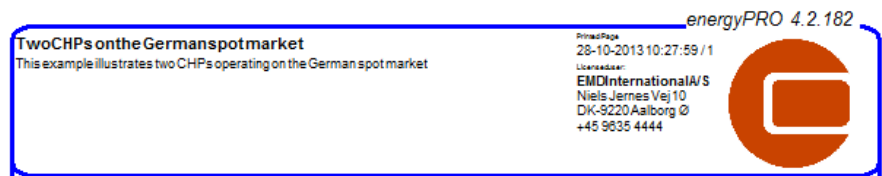

Figure 2.5: Example of company logo in energyPRO reports

Online Data

Here it is possible to change the URL specifying the location of EMD International's online data if needed.

2.2.2 Window

Here are shortcuts to all open reports.

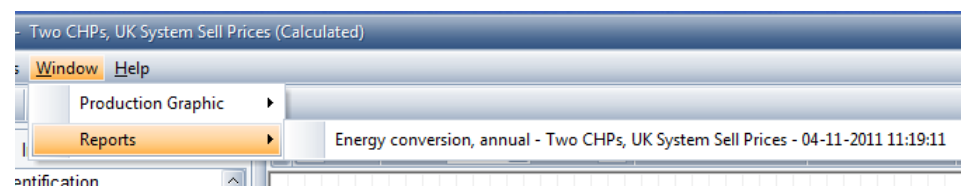

Figure 2.6: User Interface

2.2.3 Help (and license activation)

Help

The context sensitive online-help is activated by either choosing "Help|Help" or simply by pressing the F1-button.

Tutorials (Online)

Clicking this will open www.emd.dk/energyPRO/Tutorials/ in your standard browser, where you can find tutorials on how to use energyPRO.

Check for updates

There are two ways to let energyPRO check for updates. One is by clicking "Check for updates now" and another is by activating "Automatically check for updates", which lets energyPRO automatically check for updates at each energyPRO start-up.

About

In the about box you will find version number of your actual version of energyPRO and your registration data, where you can see which modules you have licensed.

How to activate energyPRO license

To work with energyPRO you need to activate your license. When buying energyPRO you will receive a license file needed for the activation.

The activation process in energyPRO is as described in the previous section 1.5 License activation

2.3 Project Identification

In “Project Identification”, there are two text fields, where comments concerning the actual project are added. The fields have different scopes.

Furthermore, “Project Identification” is the place to select, which module to use for the creation and calculation of the actual energy project.

Project identification (4 lines maximum)
This example illustrates two CHPs operating on the German spot market

Assumptions to be printed in Catalogue of assumptions

Select calculation module
Projecting
 DESIGN - calculating energy conversion in a specific year, including operational economics
 FINANCE - planning more years, including investments and financing
 ACCOUNTS - plus income statements, balance sheets and tax
Optimizing daily operation
 OPERATION - optimising operation for a short period

Advanced
 Delivery of both heat and process heat
 Starting up of production units is slow and expensive
 Fuel producing energy units in project

Show warning when demand is not met:
 Heat
 Process Heat
 Cooling
 Electricity

Length of calculation step: 1 Hour
Warning when time series changes asynchronous with calculation step:

Length of optimisation period: Month (recommended) Year

Check input data: Automatic Only before calculation

OK Cancel

Figure 2.7: Project identification and selection of projecting module

Project identification (4 lines maximum)

The project identification lines are printed in the top of every energyPRO report helping to identify the actual project.

Assumptions to be printed in Catalogue of assumptions

The text written in this part is only printed in the report “Catalogue of technical assumptions”. The text can be used for explaining some core

assumptions identifying the actual project. This might for instance make it easier to remember how this calculation differs from other calculations.

Select Calculation module

Projecting

- The DESIGN module is selected for one-year calculations, with the emphasis on energy conversion and operation costs.
- The FINANCE module is selected for investment analysis. This add Investments and Financing to the DESIGN and includes calculations running over more than one year.
- The ACCOUNT module adds the calculation of income statements and balance sheets to the FINANCE module. Adds depreciation and taxation to the calculation input.

Optimizing daily operation

- The OPERATION module is selected for optimizing the operation in a short period. The content is close to the DESIGN module, but with a few more settings.

WARNING: you might lose information when you change from ACCOUNTS to FINANCE or DESIGN or change from FINANCE to DESIGN

The selection of calculation module determines which facilities will be accessible within the project. You can always change your selection of the project module.

WARNING: If you change from ACCOUNT to FINANCE or DESIGN the specific ACCOUNTS data will be lost. If you change from FINANCE to DESIGN the specific FINANCE data will be lost.

Advanced

There are three groups of advanced settings. The first one is concerning production options, the second group is concerning warning issued when demands are not met and the last group relates to configuration of the optimization.

Advanced

Delivery of both heat and process heat
 Starting up of production units is slow and expensive
 Fuel producing energy units in project

Show warning when demand is not met:

Heat
 Process Heat
 Cooling
 Electricity

Length of calculation step: 1 Hour Warning when time series changes asynchronous with calculation step

Length of optimisation period: Month (recommended) Year

Check input data: Automatic Only before calculation

Figure 2.8: Project identification –advanced

Production options

Checking the advanced setting is only recommended in very specific situations. The available production options are:

- Delivery of both heat and process heat
- Starting up production units are slow and expensive
- Fuel producing energy units in project

The first option is typical used in a situation with both high temperature process heat demands and low temperature domestic heating demands. If this option is selected you will have the option to add both the usual heat demands and process heat demands to your project, and to model production units having both heat and process heat productions.

The second option is used in situations, where the starting up time on a production unit is long and expensive. This could be the case in projects dealing with biomass and waste. If this option is selected there will be access to fill in the duration of starting up and closing down period when defining your production units, see Figure 2.9.

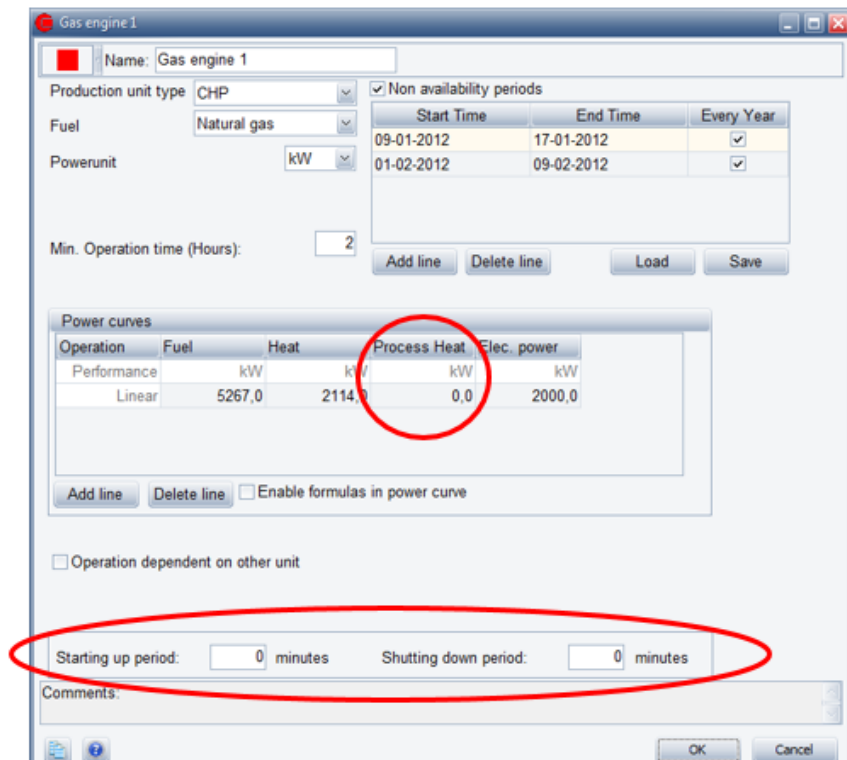

Figure 2.9: Production unit with two advanced options enabled. Starting up and shutting down periods shown and process heat available.

The third option enables fuel producing units, which are able to produce output fuel other units need as input. When this option is enabled a new data field appears in the energy conversion unit, Fuel output:

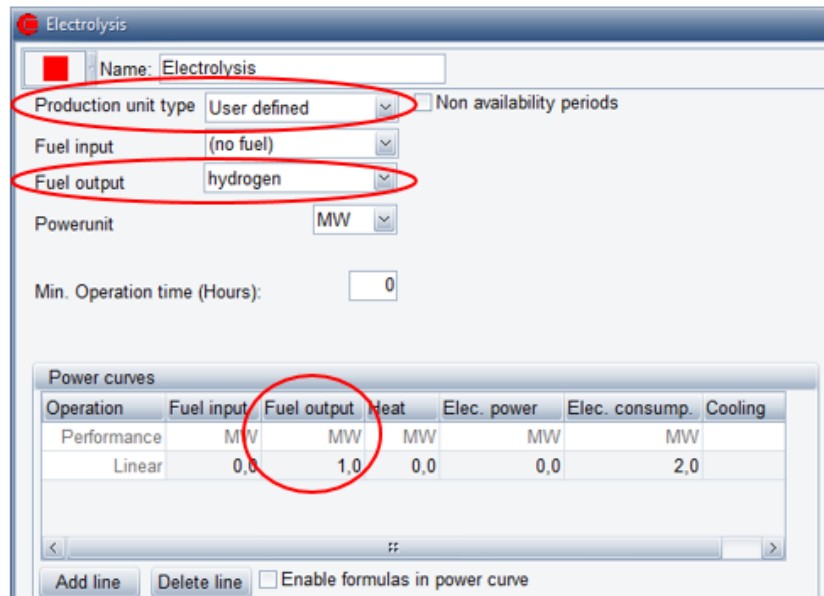

Figure 2.10: User defined production unit with “Fuel producing energy units in project” enabled

You have to change the Production unit type to User defined. Then, Fuel output is added in the Power curves.

Show Warning when demands are not met

By default, warnings are issued when Heat, Process heat or cooling demands are not met, but not for electric demands. If you for some reason might want to change this default setting, you can do this here in the Project Identification under the Advanced settings.

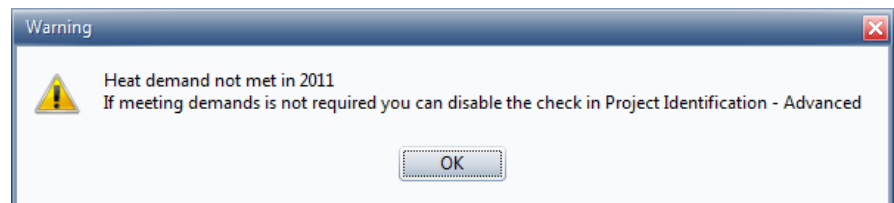

Figure 2.11: Example of warning issued when a the heat demand is not met

Calculation setup

In the advanced options you also have the possibility to configure the optimization engine to some extent. These settings will primarily influence preciseness of the optimization and the time it takes to run an optimization. The settings are:

- **Length of calculation step:** The optimization engine divides the optimization period into steps and this setting defines the size of these steps. The shorter the calculation step, the more precise the optimization ought to be because changes can occur more often. However, shortening the calculation step will increase the calculation time. By default this setting is set to 1 hour since many time series will be in this resolution. By activating “Warning when time series changes asynchronous with calculation step” a warning will be

shown if any time series are more detailed than the calculation step.

- Length of optimization period: When energyPRO calculates energy conversion for a project it will by default do this by splitting the whole optimization period into individual months and then calculate them one by one. This is primarily done to speed up the calculation. If you want a more precise optimization you can try to change this option to Year so that an entire year is calculated in one optimization. Be aware that this can be time consuming and will not always result in significant differences.

Check input data

In the standard operation mode, energyPRO automatically checks the integrity of the data structure while editing. There are some cases often with comprehensive time series, where this checking is too time consuming to work with. In this case, you have the option to check the “Before calculation only”-option. This will remove the automatic integrity checking while editing and only perform it when making calculations.

2.3.2 Project reports

Under Project identification you will also find a sub-folder called Project reports. A project report is a collection of other reports. The idea is that the user can select a number of reports to be printed in a single report which makes it easier for the user to produce a full report for the project.

The project reports are stored in the project and can be saved to a file and then imported in other projects.

To add a new project report you simply right-click on the Project reports sub-folder and Select “Add new project report”. You can give the project report a name to easily identify it later on. Once you have added the project report you can edit it to select the individual reports you want to be included.

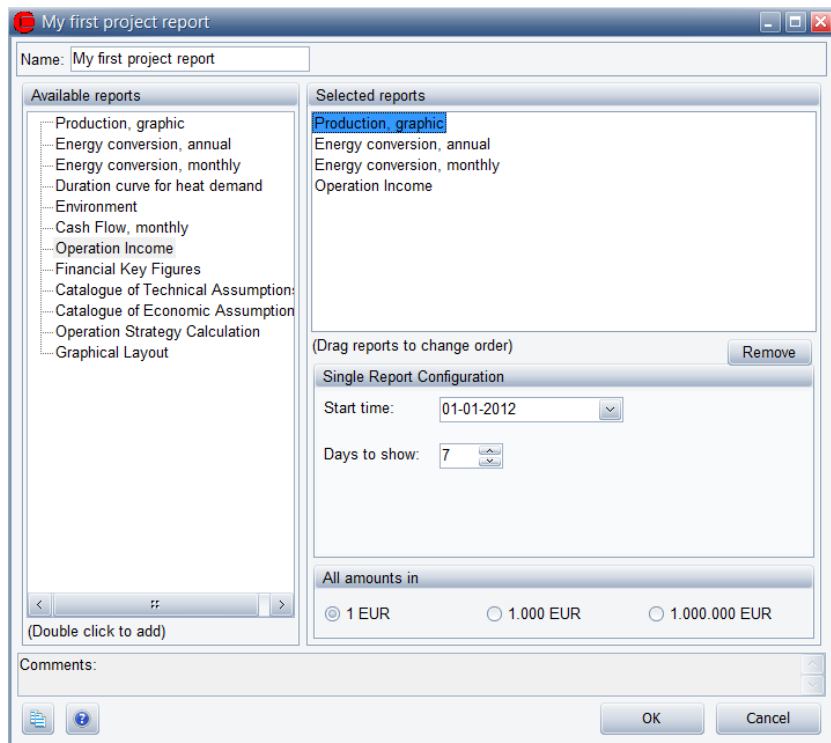

Figure 2.12: Edit window for project reports.

In Figure 2.12 you see the project report edit window which lets the user add individual reports to the project report. On the left hand side all the available reports are shown and on the right hand side the actual reports in the project report are shown. To add reports to the project report you simply Double-click the item on the left hand side. Once the report is added you can configure how the report should look in the final project report.

The example shown in Figure 2.12 shows a project report containing 4 individual reports:

- Production, graphic
 - This type of report requires that the user selects the period to show in the report, which in this case is 7 days starting at 27-01-2011
- Energy conversion, annual
 - This type of report needs no further configuration
- Energy conversion, monthly
 - This type of report needs no further configuration
- Income statement
 - As this is an economy report it requires the user to select the payment lines to show and it will be generated using the select currency in “All amount in”

Once a project report is added it will be available as an item under Project reports in the Report window (on the bottom left side of energyPRO). When the project report is printed the reports in it will simply be generated in the order they appear in the edit window.

2.4 External conditions

The “External conditions” folder serves as parent folder for indexes and time series and time series functions. Hereto comes that the connected editing window is the place to define the “planning period” and eventually to specify use of holidays in the calculation.

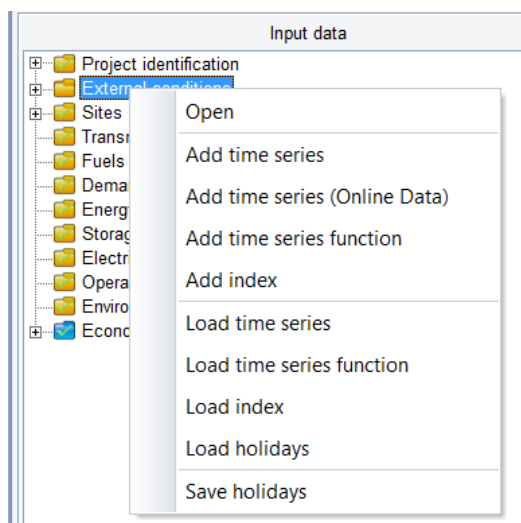

Figure 2.13: External conditions – sub folders

2.4.1 External conditions – Input form

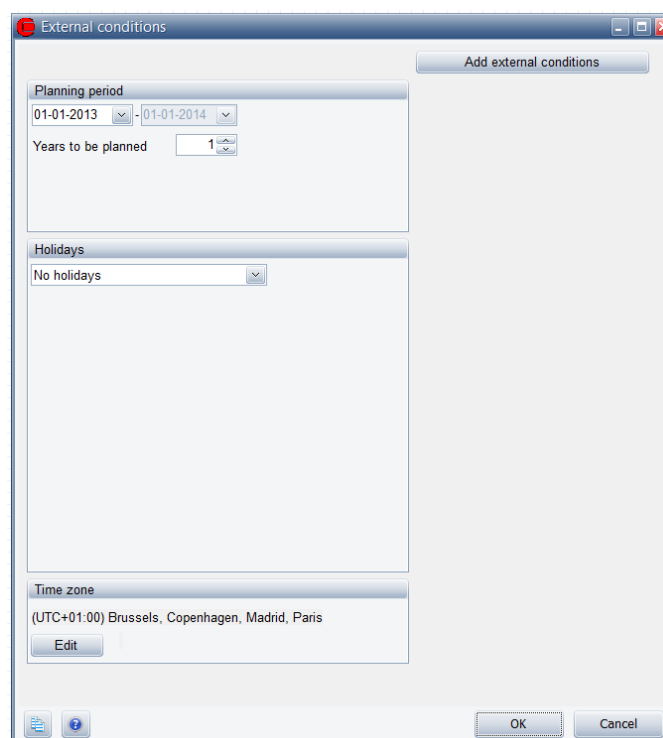

Figure 2.14: External conditions editing window

Planning period and Years to be Planned.

Here you state the start of the period, which are calculated. Note the possibility to state a displaced financial year.

Specifying holidays is only relevant if holiday dependent fixed tariffs is modelled in "Electricity markets"

If DESIGN is chosen, the planning period is always 1 year. The only information to set is the starting month and year. The end of planning period and "Years to be planned" are dimmed and not accessible.

If FINANCE or ACCOUNTS is chosen the "Years to be planned"-parameter determines how many years there will be incorporated in the calculation.

Holidays

Specifying holidays is only relevant if holiday dependent fixed tariffs are modelled in "Electricity markets". Often the electricity tariffs are e.g. lower in holidays. Therefore, it is often relevant to know the dates of these holidays.

The present version of energyPRO has the holidays for Denmark, Germany and Great Britain encoded. For Germany and Great Britain the regional differences in holidays are also accounted for, as one will have to choose which region's holidays are needed for the model. If you are making projects in other countries, and the conditions for e.g. tariffs of electricity differ between holidays and working days, it is possible to type in country specific dates.

When entering the holiday combo box, five options become available.

- No Holidays
- Danish holidays
- German holidays
- British holidays
- Specify holidays manually

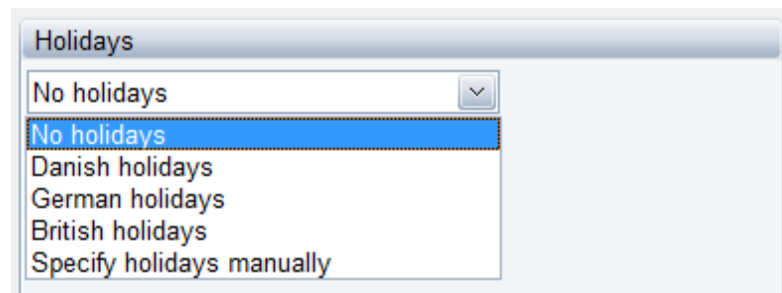

Figure 2.15: Specifying holidays manually

If "Specify holidays manually" is chosen you have to fill in each holiday by a name and a date (format: dd-mm)

It is possible to save and load Holidays. Use the right mouse button while standing in the window for holidays to get access to this facility.

Add external conditions for library

From here, you can load an existing time series from the hard disk into your project.

Time zone

When making a new project file or opening a project file previously saved in energyPRO versions 4.1 or earlier, the time zone will automatically be the same as the time zone used by the computer.

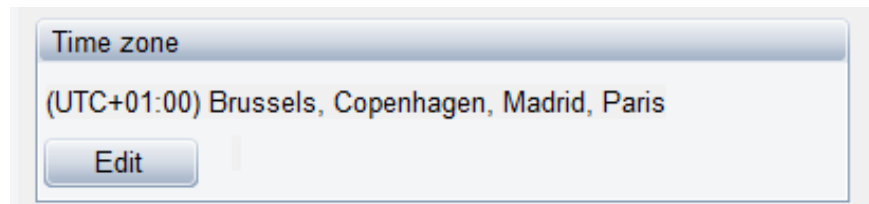

If you are going to work on a project located in a different time zone press Edit.

This gives the following window:

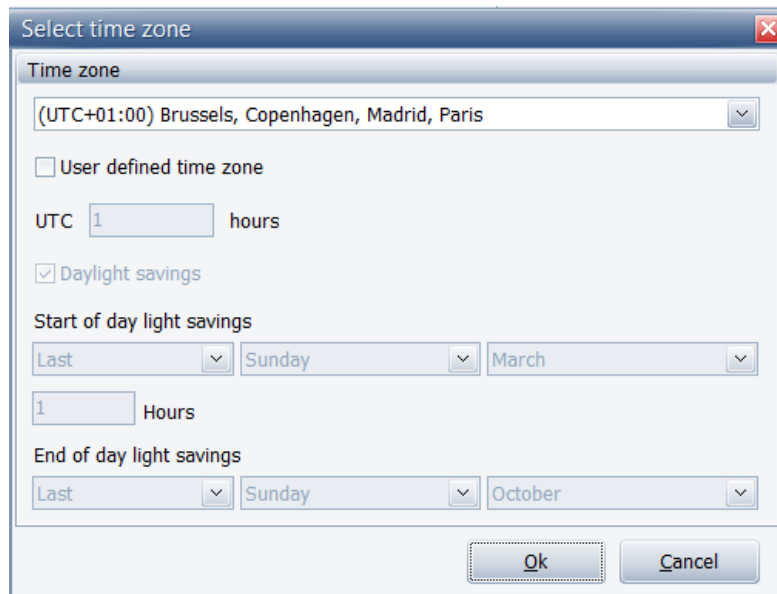

Here it is possible to change the time zone:

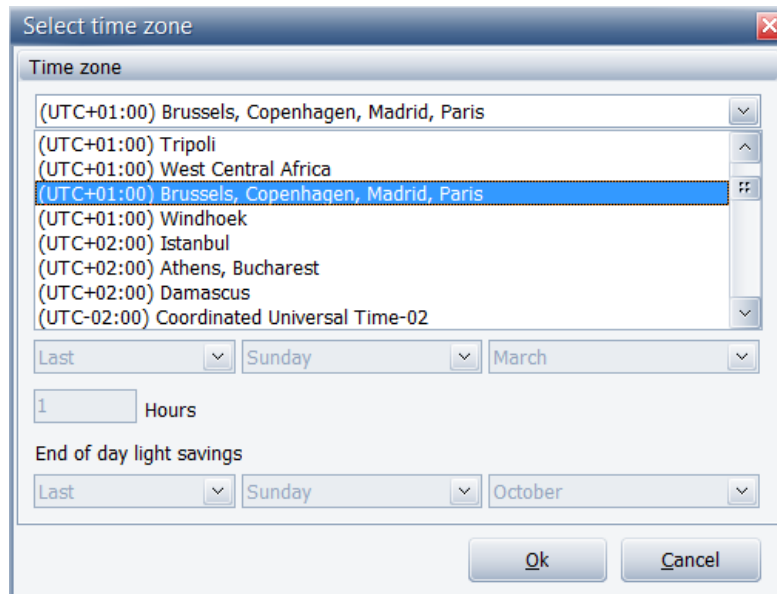

Another option is to make a user defined time zone:

Here you can specify offset to UTC. In this case the time zone is UTC +1 hour. Also, it is possible to enable or disable daylight savings and to detail the daylight saving settings.

2.4.2 External conditions - Time series

Time series are the fundamental data format in energyPRO

Time series are the fundamental data format in energyPRO. Time series relates very closely to spread sheet formats. You can copy a time series to spread sheet and you can copy a time series from a spread sheet.

A time series consists of set of values each connected to a specified date and time. The External conditions time series can be accessed from several of the other editing windows in which the project is specified.

Examples of time series are daily temperatures, hourly solar radiation or electricity spot market prices.

A typical time series example is a series to distribute a heat demand by using a time series holding the ambient temperature. Other examples of using time series are the calculation of the production of a solar plant by using a time series holding the solar radiation, and a time series holding electricity spot prices used for specifying "Electricity market" prices.

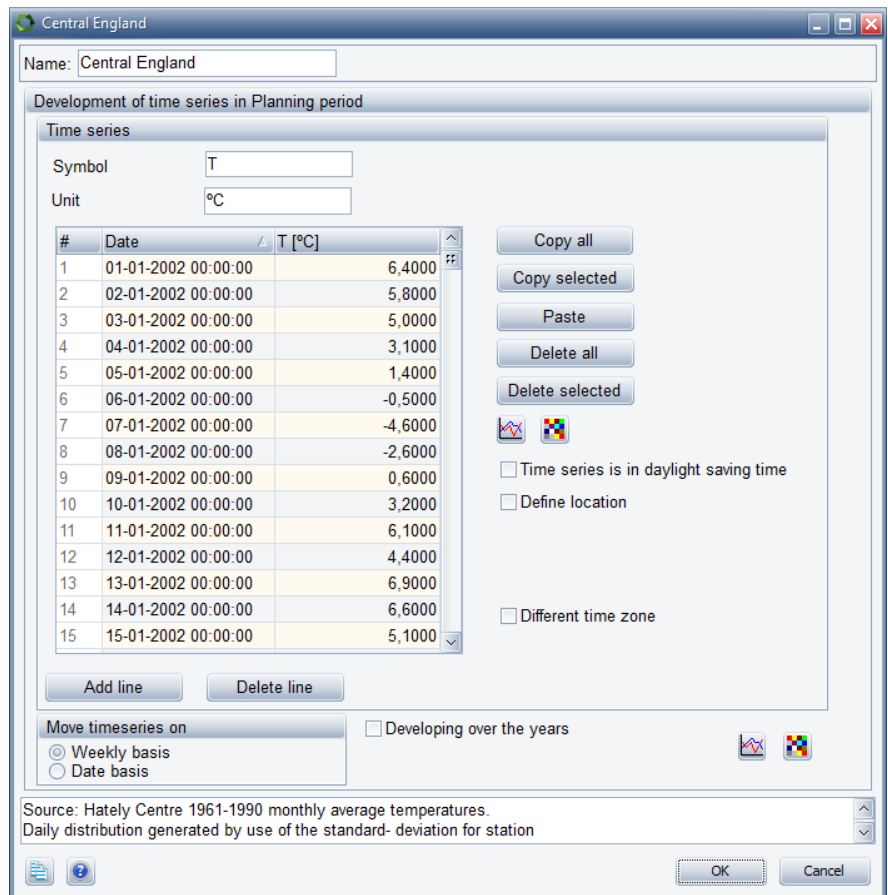

Figure 2.16: Time series – Example: Temperatures in “Central England”

Symbol

The symbol is used for referencing the time series

The symbol is a unique short name for the time series. The symbol is used for referencing the time series elsewhere in the energyPRO. All time series, time series functions and indexes, used in a project, must each have a unique symbol.

Note: The symbol is repeated in the header of the editing window.

Unit



The unit in which, the values in the time series, is stated. The unit is for presentation use only and is not evaluated during calculations.

Time series

Time series consist of rows all specified with the two fields; date/time and value, see Figure 2.16. Arbitrary length of periods between every element in the time series is allowed.

The function of the buttons:

- **Copy all:** Copy all values from the actual time series to the clipboard. From the clipboard, the values can e.g. be pasted into a spread sheet like Excel.
- **Copy selected:** Copies selected row(s) from actual time series into clipboard. Selection is to done by use of the keyboards arrow-tabs or by mouse.

- **Paste:** Pastes the content from clipboard to the time series table. Make sure you are pasting using the correct format; date/time and value. For more on importing data from a spread sheet to a time series in energyPRO, see appendices A.
- **Delete all:** Deletes all values in the time series.
- **Delete selected:** Deletes selected row(s) from the time series. Selection is done by using either the keyboards arrow-tabs or the mouse.
- **As Graphics:**  The upper “as graphics” –button gives a graphic representation of the time series table.
- **As Carpet:** 
- **Add line:** Add a new line below the active line
- **Delete line:** Deletes the active line

Time series is in daylight saving time

If the time series is in daylight saving time, enable this checkbox. This will typically be the case for price time series, such as electricity spot prices and electricity balancing prices.

Typically time series not in daylight saving time are meteorological time series.

Define location

This checkbox has to be enabled if the time series contains solar radiation values and is used in a solar collector or photovoltaic.

The latitude and longitude are specified in decimal degrees. The latitude has positive values north of equator and negative values south of equator. The longitude has positive values east of Greenwich Mean Time (UTC) and negative values west of Greenwich Mean Time.

Different time zone

If the time series is in a different time zone than the time zone of the project, this checkbox is selected.

This gives the same options as in External conditions.

A typical case can be meteorological data measured in UTC time.

Converting time series according to time zone and daylight saving time

If the time series is in a different time zone it is converted according to the difference in UTC offset.

If the projects time zone is with daylight saving time and the time series is with daylight saving time the time series is not changed. If the time series is in standard time the values are moved one hour forward in the daylight saving time period.

Likewise, if the projects time zone is without daylight saving time and the time series is in daylight saving time the values are moved one hour backward in the daylight saving time period.

Figure 2.17 shows an example, where the time series containing daily temperatures in “Central England” is represented graphically.

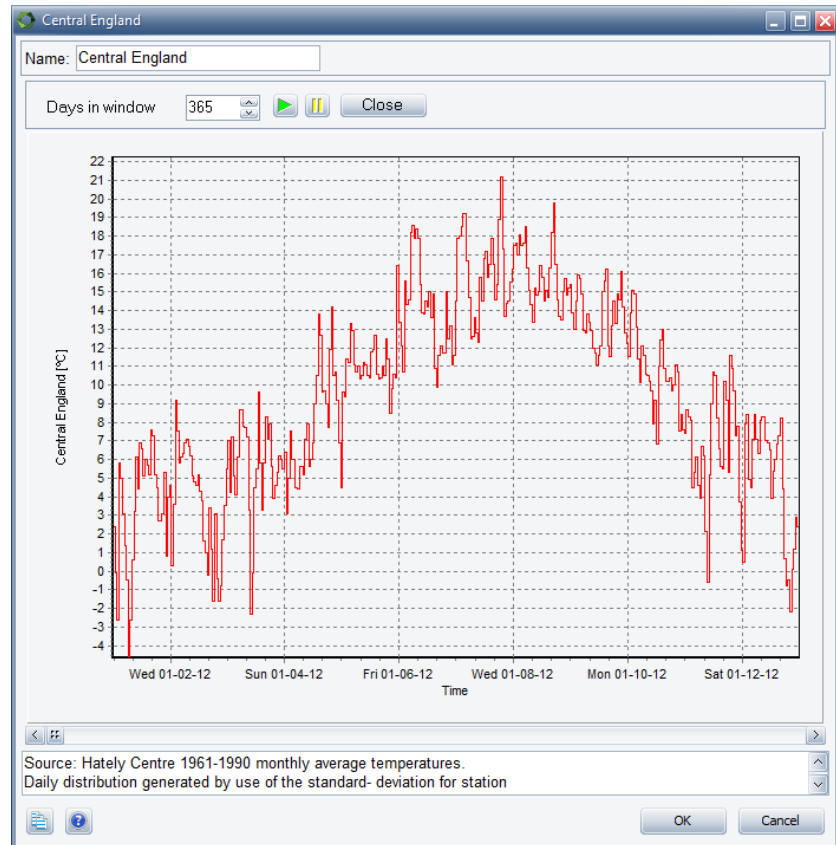

Figure 2.17: Time series – Graphic: Temperatures in “Central England”.

There is an alternative graphic view, Carpet. This view has the days on one axis and hours on the other axis. The Carpet view seen below show an example solar radiation for London. This view show not surprisingly that the solar radiation is concentrated in summertime and round midday.

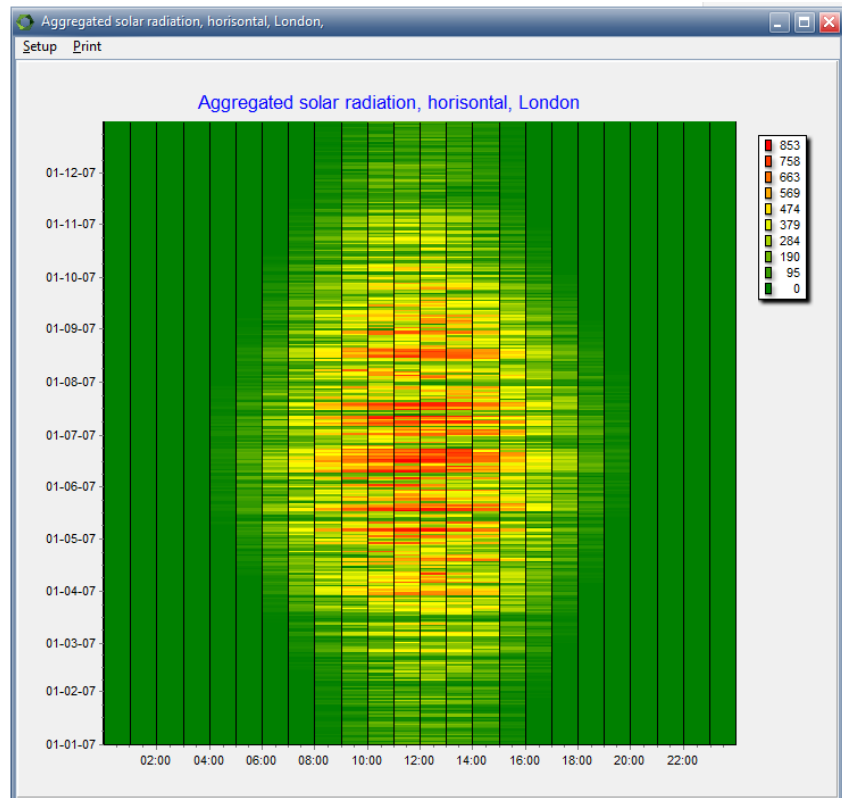

Figure 2.18: Time series – Carpet view: Temperatures in “Central England”.

It is possible to tailor the carpet view via the setup menu in the top of the view. When the project is saved these settings are saved along with the project.

The options are:

- Dates on specified axis
- Vertical axis Lowest value from bottom or top
- Number of intervals
- Color of intervals
- Filtering to avoid extreme values

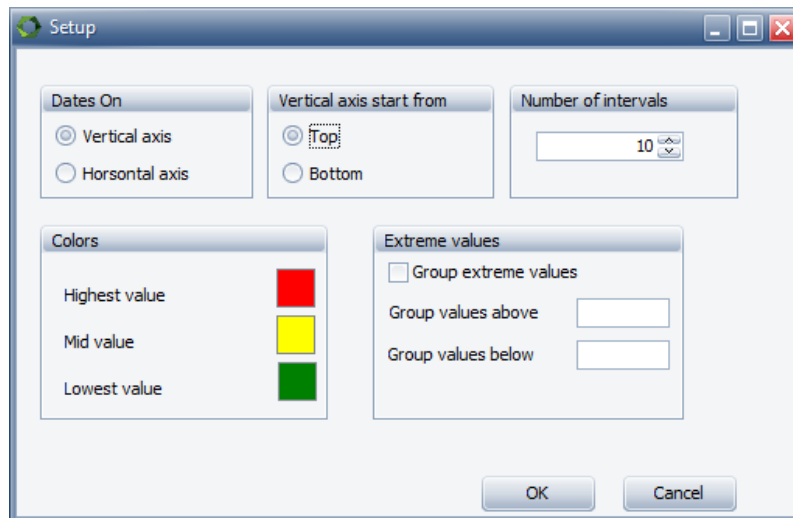

Figure 2.19: Time series – Carpet view: Setting options.

Move time series on

When time series are extended/ copied to another period than actual specified there are two options. The first option is to move the time series on weekly basis (i.e. values in week 2 are moved to week 2 in the following years) and the second is to move on date basis (i.e. values in February 2nd are moved to February 2nd in the following years).



Figure 2.20: Time series –Move time series options.

Developing over the years

It is possible to add an index to describe the development of a specified time series. To do this check the “Developing over the years” – option and select a previously created index. For the creation of indexes, see section 2.4.5. energyPRO develops a time series over time by moving the values as indicated above After moving the values, energyPRO changes the values on a monthly basis according to the selected index.

When the editing windows lower “as graphics”-button is pressed the time series is transformed for the whole planning period. If an index is selected, the index is taken into account.

Similarly when the editing windows lower “as carpet”-button is pressed the time series is transformed for the whole planning period and shown as carpet. If an index is selected, the index is taken into account.

Duplicated values

Note that energyPRO tries to keep the time series as simple as possible

are eliminated in order to improve performance.

in order to improve performance, this means that duplicated values is removed. For instance if coping a time series with 365 daily temperatures you might end up with a time series holding only 320 daily values.

2.4.3 External conditions – Online Data

Instead of importing climate time series from files and spread sheets, energyPRO offers the opportunity to do this using online data provided by EMD International.

NCAR Data

The data originates from the NCAR reanalysis project which provides climate data four times daily in a global grid since 1948 to present. The data available in energyPRO are:

- **Air temperature** : Instantaneous air temperatures in Celsius calculated at 0, 6, 12,18
- **Wind speed** : Mean wind speed in m/s at 10 meters calculated at 0-6,6-12,12-18,18-24
- **Air pressure** : Mean air pressure in HPa calculated at 0-6,6-12,12-18,18-24
- **Relative humidity** : Mean relative humidity in % calculated at 0-6,6-12,12-18,18-24

energyPRO offers the possibility to convert NCAR data into intervals that differs from the standard four times daily. You can either convert the data to 24 times daily or one time a day.

The conversion from four times daily to 24 times daily is done using linear interpolation, so e.g. if the air temperature at 0 is 2 degrees and at 6 it is 8 degrees, the calculated air temperatures will be:

Time	Air temperature	Source
0	2	From NCAR
1	3	Calculated
2	4	Calculated
3	5	Calculated
4	6	Calculated
5	7	Calculated
6	8	From NCAR

The conversion from standard four times daily to one time a day is simply done by finding the mean value of the four NCAR values from that day.

CFSR data

CFSR is an abbreviation for Climate Forecast System Reanalysis. Like NCAR CFSR is based on a wide range of data sources, such as surface weather stations, weather balloons, airport reports, commercial aircrafts and satellite measurements.

The CFSR data has a global grid resolution of 0.3 x 0.3 degree and one hour time resolution.

Time series from 1980 to 2010 can be downloaded. Time series from 2011 is available as CFSR 2. CFSR 2 has a grid resolution of 0.2 x 0.2 degree and 1 hour time resolution.

The CFSR data has the following data set:

- Air temperature [C]
- Solar radiation [W/m²]
- Wind speed [m/s]
- Precipitation [mm]
- Humidity [%]

Adding time series from online data

To add time series from online data you can either use the globe icon button at the toolbar or right click on the External Conditions folder in the folder structure, as shown in Figure 2.21.

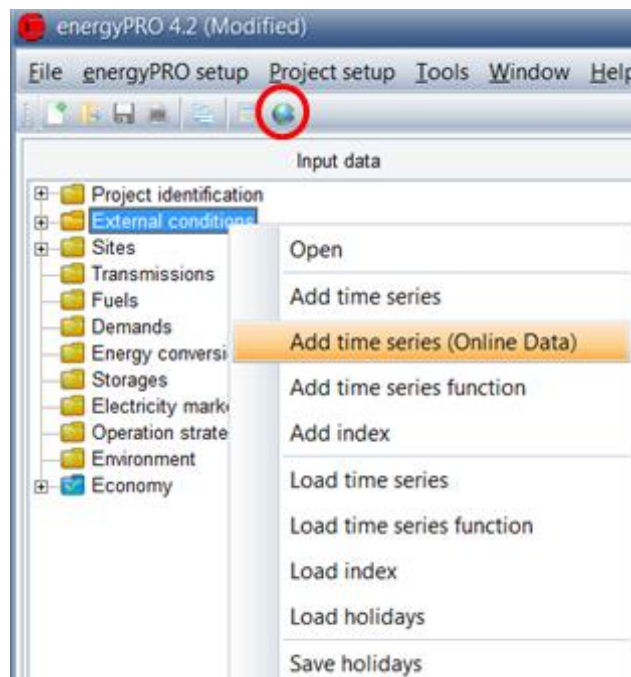

Figure 2.21: Shows how you can add time series from online data. Either, it is accessed via the folder structure, or it is accessed using the icon in the toolbar

After using either of these methods you will be presented with the window shown in Figure 2.22.

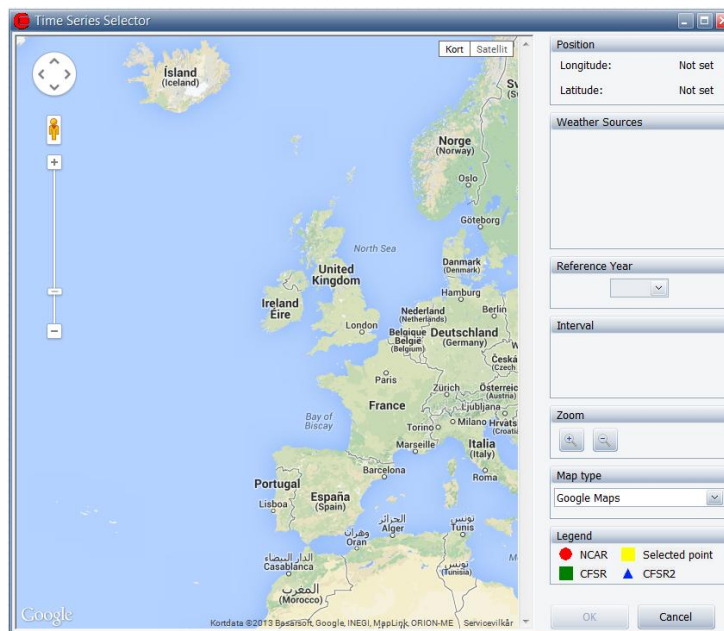

Figure 2.22: Dialog presented when adding time series from online NCAR data

In the window a map is presented on the left-hand side which is used to select the coordinate you wish to add climate time series from. To move the globe around you press and hold the left mouse button while dragging the mouse around. You can zoom in by moving the mouse wheel up and zoom out by moving the mouse wheel down.

Once you have the area of interest in focus you can click on the globe with the left mouse button. This will ask the online server for the nearest data which will be presented on the globe with dots as shown in Figure 2.23.

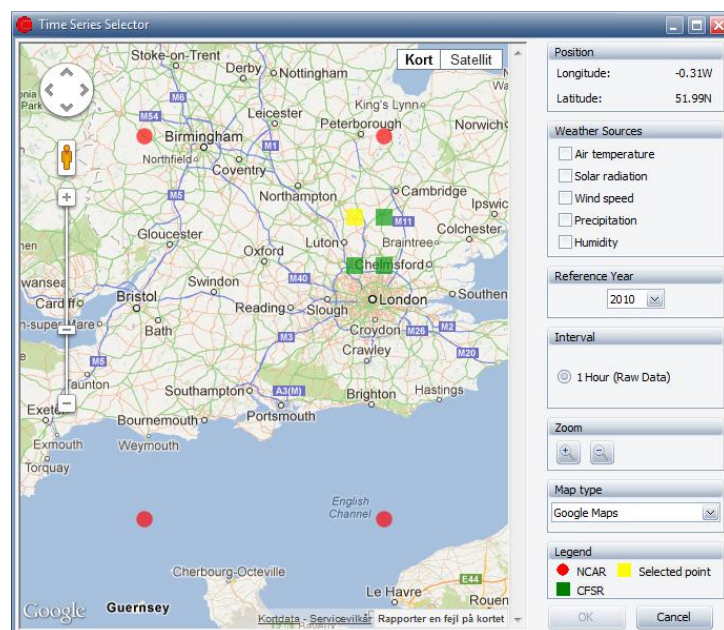

Figure 2.23: Shows the globe view after the nearest NCAR data points have been fetched

The red dots represent NCAR data and the green dots represent CFSR data.

Once the nearest data sources are shown you select one of them by clicking on it with the left mouse button.

The next step is to select which climate data you are interested in which is done by clicking the checkboxes in the Weather sources group. For each checked weather source, a time series will be created.

Before the time series can be fetched from the online server and created in energyPRO you need to select a reference year for the data. In the drop down box you simply select the reference year.

After selecting the reference year you can go ahead and click Ok to create the time series.

However, if selecting NCAR data and you want the time series to be created in different intervals than the standard four times daily you can choose a different interval in the Interval group box. Please refer to the section on NCAR Data earlier in this chapter to find details on how the conversion is done.

Once you click the Ok button energyPRO will contact the online data server provided by EMD International to fetch the selected climate data. For each weather source that was selected it will create a new time series with default names and symbols. You can rename the time series and symbols as you want.

2.4.4 External conditions - Time series functions

Time series functions are primarily meant for modifying existing time series. An example of a time series function is shown in Figure 2.24.

Symbol

The symbol is used for referencing to the time series function

The symbol is a unique short name of the time series. The symbol is used for referencing the time series elsewhere in the energyPRO. Any time series, time series functions and indexes, used in a project, have to use different symbols.

Unit

The unit in which, the values in the time series, is stated. The unit is for presentation use only.

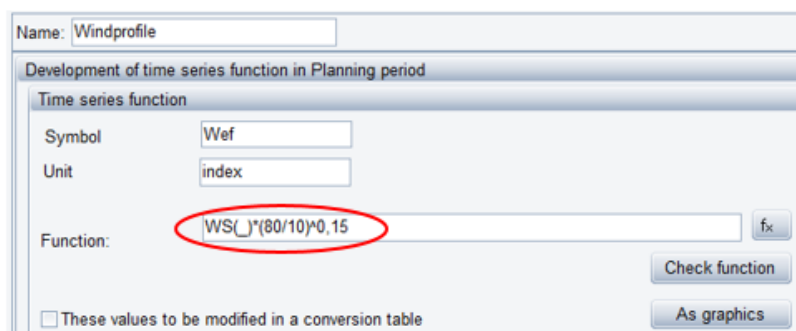

Figure 2.24: Example of a time series function, where a wind velocity in 10 meters height is modified to wind velocity in 80 meters height.

Function

In the function field, you have the option to define a function. If you press the F_x -button, you can see which functions are available for defining your time series function.

If you need a more detailed description of the functions please see chapter 4 “Functions in energyPRO”, that serves as a reference-section describing the functions available in formula fields in energyPRO.

In the function shown in Figure 2.24 a time series is modified. In this example the function modifies a wind speed velocity in 10 meters height to a wind velocity in 80 meters height using a wind gradient exponent of 0.15.

The expression $WS(_)$ refer to a time series, holding hourly values of wind velocity measured in 10 meters height. This time series has the symbol WS . Each value in this time series is modified with the factor $(10/80)^{0.15}$.

These values modified in a conversion table

An advanced option is to check “These values to be modified in a conversion table”. This gives an extra opportunity to modify a time series function.

In Figure 2.25 is shown a conversion table representing the power curve of a wind turbine. This table modifies the time series function shown above in Figure 2.24, so the output is a time series function holding variations in energy in wind instead of variations of wind velocity.

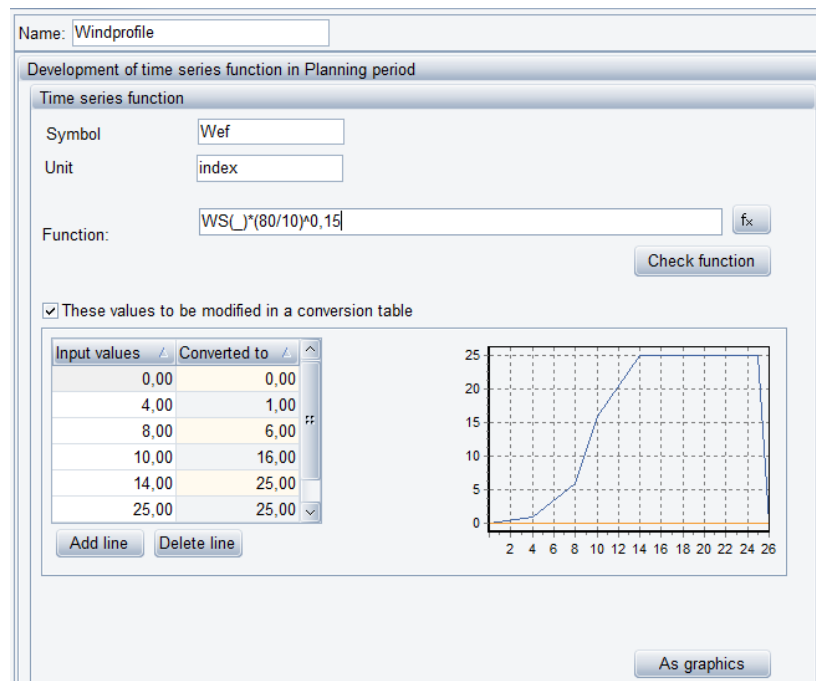

Figure 2.25: Time series function example, where a wind velocity in 10 meters height is modified to wind velocity in 80 meters height and finally converted to energy output using a conversion table, which describes the power curve of a wind turbine.

Figure 2.26 shows the graphical representation of the time series function example before and after the conversion table modifies it.

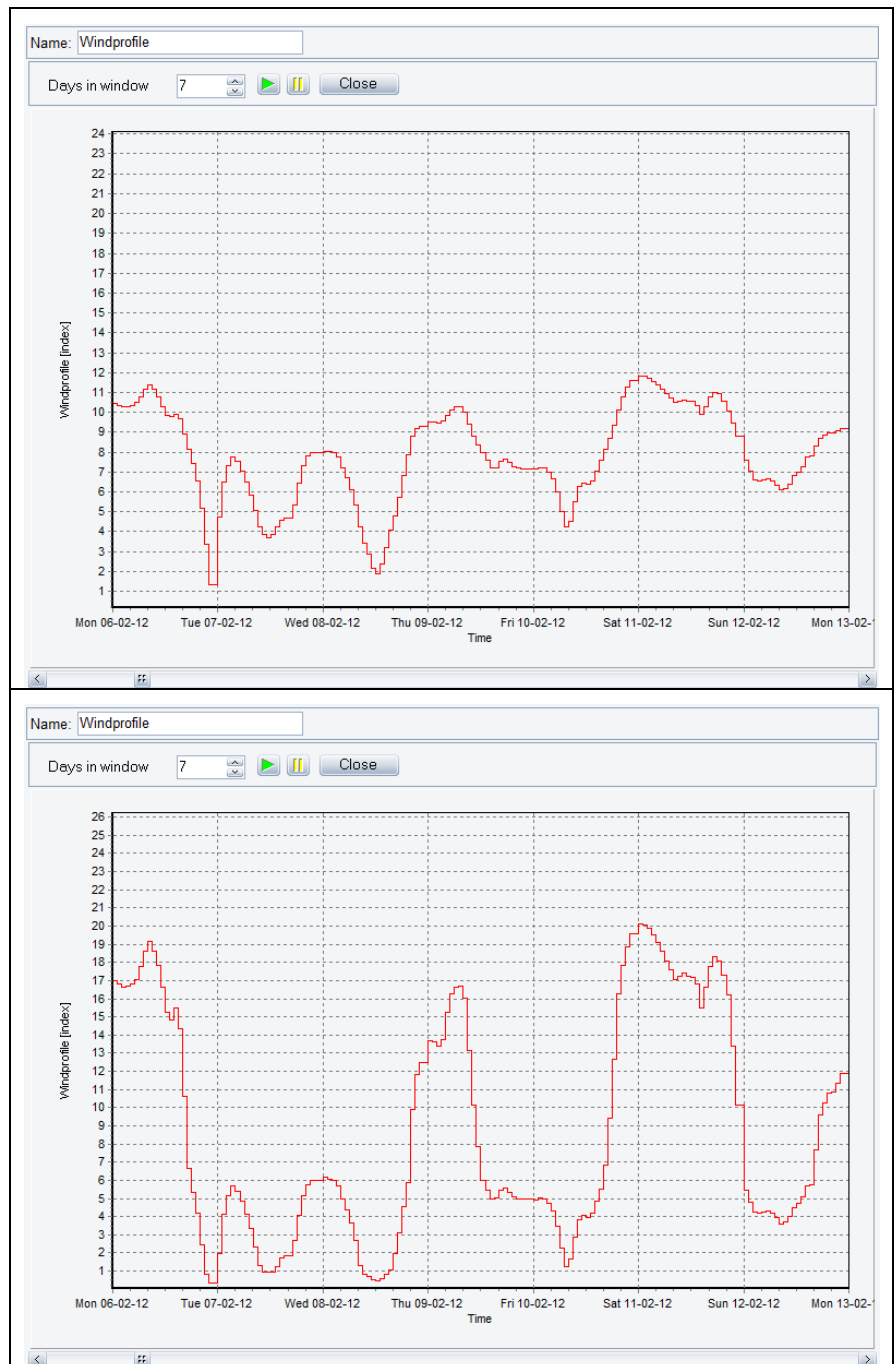

Figure 2.26: Time series function example shown graphically. Upper before modifying in conversion table. Lower after modifying in conversion table.

2.4.5 External conditions - Indexes

Indexes are used to describe developments in demands and prices

Indexes specify the development of a specific parameter. Indexes are in energyPRO used to describe developments in demands and prices. There are three ways of adding an index to a project.

- Constant annual increase
- Annual increase

- Index

Symbol

The symbol is used for referencing indexes

The symbol is a unique short name of the time series. The symbol is used for referencing the time series elsewhere in the energyPRO. Any time series, time series functions and indexes, used in a project, must have unique symbols.

Constant annual increase. The index changes annually with the percentage typed in. In other words, it changes exponentially and is updated monthly. The index covers the total project period. Index is always 100 on the project start date.

Annual Increase is used if the index has to reflect a shift in rate of change. If the first year in the table is before the project start date then the index on project start date is the value calculated based on input from the table, otherwise index is always 100 on the index start date. The index changes exponentially (yearly update).

Index is used in situations, where you have a series of values (for instance the retail prices index) with values that you want to use if monthly specification is wanted. The index does not change between the indexes typed into the table.

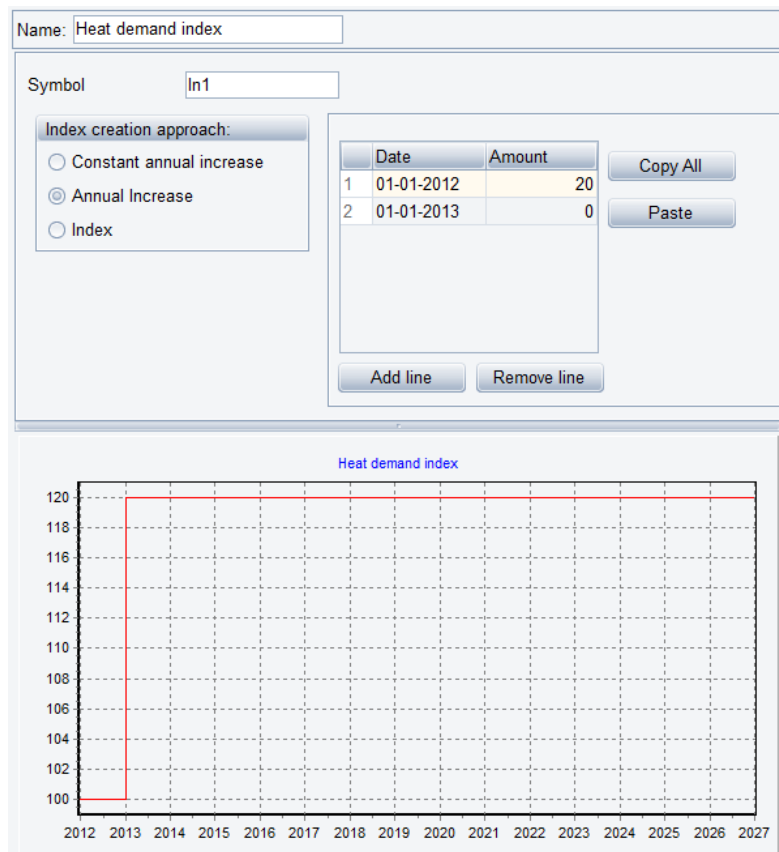

Figure 2.27: Index – example

The example shown in Figure 2.27 is an index used for development of a specific heat demand. Within the first year of the projecting period the

heat demand is expected to raise 20% due to connection of new consumers. Annual increase is chosen. In the first projecting year, 2012, the annual increase is 20% and hereafter 0 %. The result is shown in the graphic in the bottom of the window.

2.5 Sites

The Sites folder is primarily used in projects with more sites where the parent folder shows an overview of the different sites and transmissions.

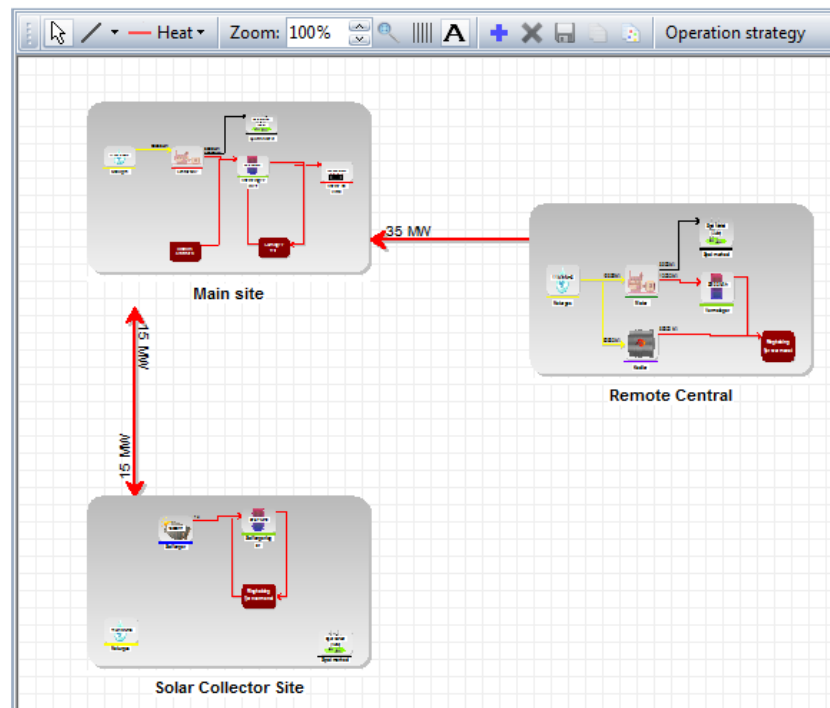

Figure 2.28: Screenshot that shows an example of a site overview with 3 different sites and two transmissions

The graphical overview of a single site is shown either by clicking on its subfolder in the Sites branch or by double-clicking on it in the graphical Sites overview. The appearance and functionality of the graphical overview of a single site is described previously in section 1.8.

2.5.1 Adding more sites

If you have purchased the REGION module you can add more sites to a project in three different ways as shown in Figure 2.29.

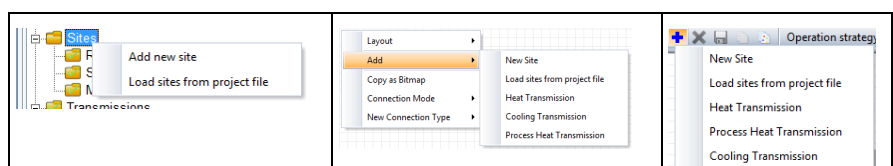

Figure 2.29: New sites can be added either by right-clicking on the Sites main folder in the tree structure, via the popup menu on the graphical interface or via the Add button in the graphical toolbar

Besides adding a new empty site it is also possible to load sites in to your project. When loading sites in to your project the loaded file is another energyPRO project file. So basically this functionality can be used to merge two or more energyPRO projects.

When loading sites from another project file energyPRO will try to identify the identical external conditions, fuels and economy lines so that these are not duplicated in the final project. However, it is strongly recommended that the user verifies that the merging was done in the desired way.

2.5.2 Adding transmissions

The graphical sites overview can also be used to add transmissions between sites. As it can be seen in Figure 2.29 transmissions can be added via the popup menu on the graphical interface or via the Add button in the toolbar. This way of adding transmissions will simply add a transmission between two sites that are not yet connected or report an error if all sites are already connected.

Another way of adding transmissions is by dragging a line between two sites. First you select the type of transmission in the toolbar and you then select connection mode.

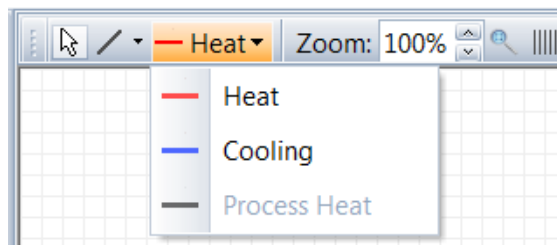

Figure 2.30: To add transmission by dragging a line you select the type of transmission and then go to connection mode

Adding connections in the graphical overview is described in more details in section 1.8.7.

2.6 Transmissions

The Transmissions folder contains all the transmissions between sites in the project. Each transmission is defined by the following attributes:

- Energy type, which can be transmitted: Heat, Cooling and Process Heat
- The two sites that the transmission is connected to
- Attribute that tells in what directions the energy can be transmitted
- The capacity of the transmission, which can be defined by functions and time series. The capacity is the same in both directions.
- The loss on the transmission, which can also be defined by functions and time series. In the current version of

energyPRO the loss is not relative to the amount of energy transmitted, but merely a constant (can vary over time) loss. Transmissions are added to the project as described in section 2.5.2.

The screenshot shows the 'Transmission' dialog box with the following details:

- Name:** Transmission
- Type of Transmission:** Energy Type: Heat
- Sites:** Site A: Site 1, Site B: Site 2
- Direction:** Site A can transmit to B, Site B can transmit to A (both checked)
- Capacity and Loss:** Capacity [Cap]: 10 MW, Loss: 1 kW
- Non availability periods:**

Start Time	End Time	Every Year
01-09-2012	03-09-2012	<input checked="" type="checkbox"/>
- Operation restricted to period:** 01-06-2011 - 01-01-2012 (checked)

Figure 2.31: Screenshot of the Transmission input form

2.6.1 Restricting when transmissions can be used

There are two different ways of restricting the use of transmissions:

- **Non availability periods:** This option can be used for yearly maintenance periods where the transmission is not available. In Figure 2.31 it can be seen that the transmission is unavailable every year from the 1st of September until the 3rd of September.
- **Operation restricted to period:** If a transmission is not available from the beginning of the planning period this option can be used to define when the transmission will be available. As an example you can see in Figure 2.31 that the transmission is not available before the 1st of June 2011

2.6.2 What about fuel and electricity transmissions?

In the current version of energyPRO it is not possible to restrict transmission of Electricity and Fuel between the sites. This means that all sites are connected to each other with Electricity and Fuel transmissions. So if you have a restricted Fuel it will be available on all sites and the storage is common for all of them.

In the same way an electricity producing unit can produce electricity for an electricity demand on another site.

2.7 Fuels

Load or add fuel data via the main menu or via the fuel- folder

You have two options for including the fuels used in your project. The first option is to include them from a library. The second option is to add a new fuel.

You can use earlier saved sets of fuels as a starting point, when you edit data. Right click in the input data folder structure at “Fuels”, select “Load” and choose the data you want to import. The imported data are now present in the editing window and can now be edited.

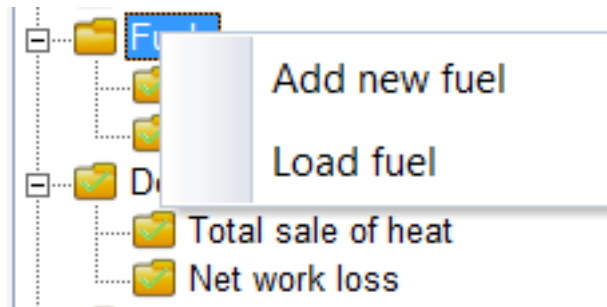

Figure 2.32: Adding fuel data via “Fuel”- folder

If you want to add new data then right click in the folder structure at Fuels and select “Add new fuel”. An empty fuel editing window is now shown and your data can now be filled in.

2.7.1 Editing options for editing a specific fuel

Figure 2.33 shows the editing options when editing a specific fuel. Beside the “load” and “add” options, there are the options to:

- Copy fuel – making a new copy in the fuel folder
- Rename fuel – setting the active fuel folder name in editing mode
- Delete fuel – Deleting the active fuel-folder
- Save fuel – Saving the active fuel, invoking a save dialog

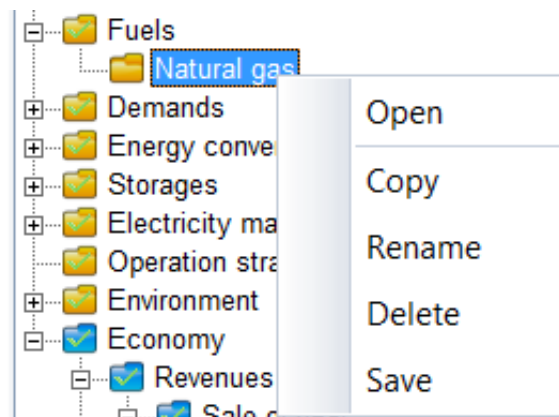

Figure 2.33: Editing options for a specific fuel

2.7.2 Editing the data fields

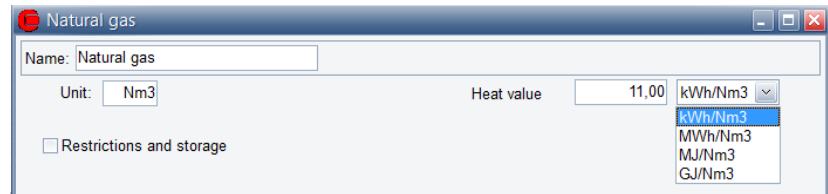

Figure 2.34: Simple fuel (no Restrictions and storage)

Unit

You type the name of the unit (amount), in which the fuel is delivered, e.g. biogas can be delivered in 'm³' (cubic meter) or it can be delivered in 'MWh'. This unit is for information use only. The unit is for instance used in the Heat value combo-box placed to the right.

Heat value

The heat value consists of two data fields. In the first you type the heat value as a number. The second field is a combo-box in which you choose the corresponding energy unit.

Restrictions and storage

If you cross mark this field, you get access to restrict the fuel amount offered and to specify fuel storage.

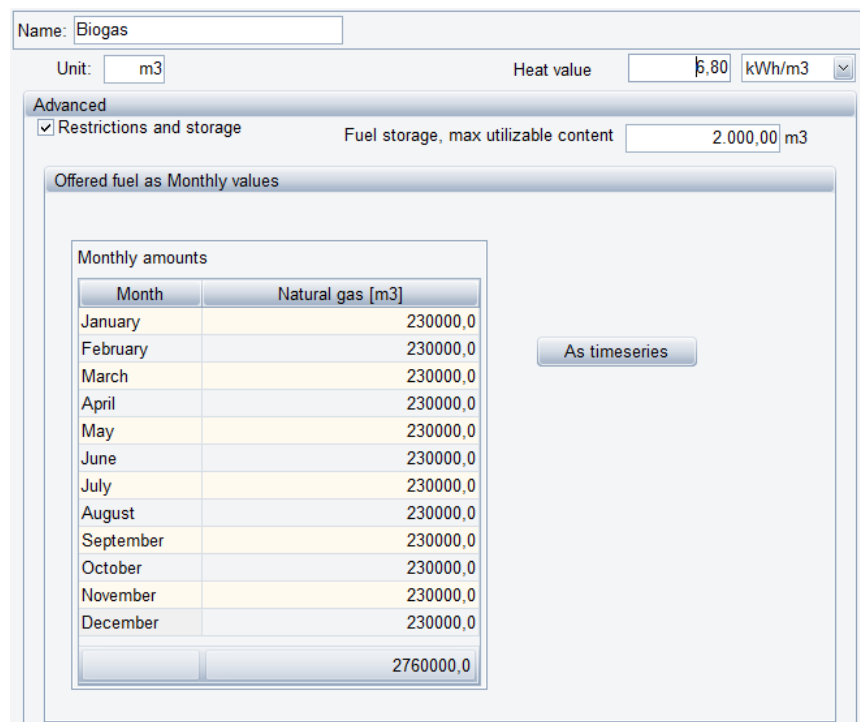

Figure 2.35: Fuel with restrictions - biogas example

Fuel storage, max utilizable content

This parameter states the maximum utilizable content (amount) of the fuel storage.

Offered fuel

Specify how much fuel your production units are offered of the actual fuel each month. The amount of fuel that is not consumed will be put into the storage as long as it is possible. Remaining fuel will not be utilized.

As time series

You can convert the offered fuel into time series by pressing the “As time series”-button or by right clicking the mouse standing in the editing window. This gives you the possibility to type in data as accurate as you wish.

2.7.3 Using fuel when defining energy Unit

To make use of a fuel in your energy calculations you have to choose the fuel when defining your energy units.

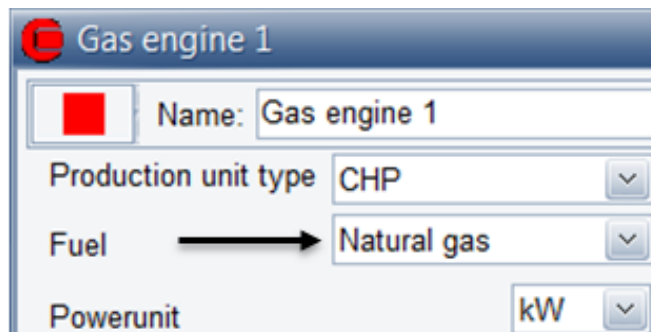

Figure 2.36: Selecting fuel into an energy production unit.

If “Fuel producing energy units in project” has been ticked in the “Project Identification” then a dropdown box called “Fuel output” is added between the fuel input dropdown box and the Powerunit dropdown box.

2.8 Demands

Heat (and Process Heat), Electricity and Cooling demands can be specified within energyPRO. An unlimited number of demands can be specified, and in any detail.

Detail costs. The more demands and the more details the longer calculation time.

All the demands will be summarized before the energy calculation. This gives you an opportunity to make a detailed description of the heat demand. But note that detail costs in calculation time. The more demands and the more details the longer calculation time.

When specifying a demand the first question to be answered is whether the demand is a fixed amount to be distributed in time or a calculated demand. The second question is whether the demand is dependent of external conditions. An external condition would normally be a time series holding ambient temperatures.

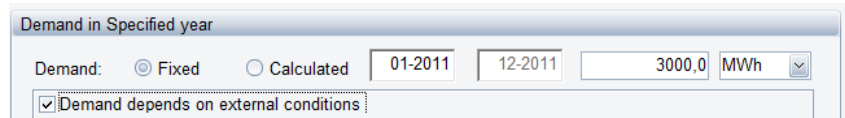

Figure 2.37: Fixed or calculated demand/Demand depends on external conditions

Note that all demands can be converted into a time series representation by pressing the time series button. After this conversion the user has the option to modify this time series as with external conditions.

2.8.1 Demand do NOT depend on external conditions

In its most simple form, a demand is just one single value covering the annual demand or the independent power demand in MW.

Demand is fixed

In Figure 2.38 the only number specified is the annual demand of 3000 MWh. The demand will then be distributed evenly all over the year, taking into account the number of days in the months. The resulting monthly amounts are shown in the “Monthly amounts”-table in the bottom of the window. Note that you have the opportunity to type in and/or change the monthly amounts in that table.

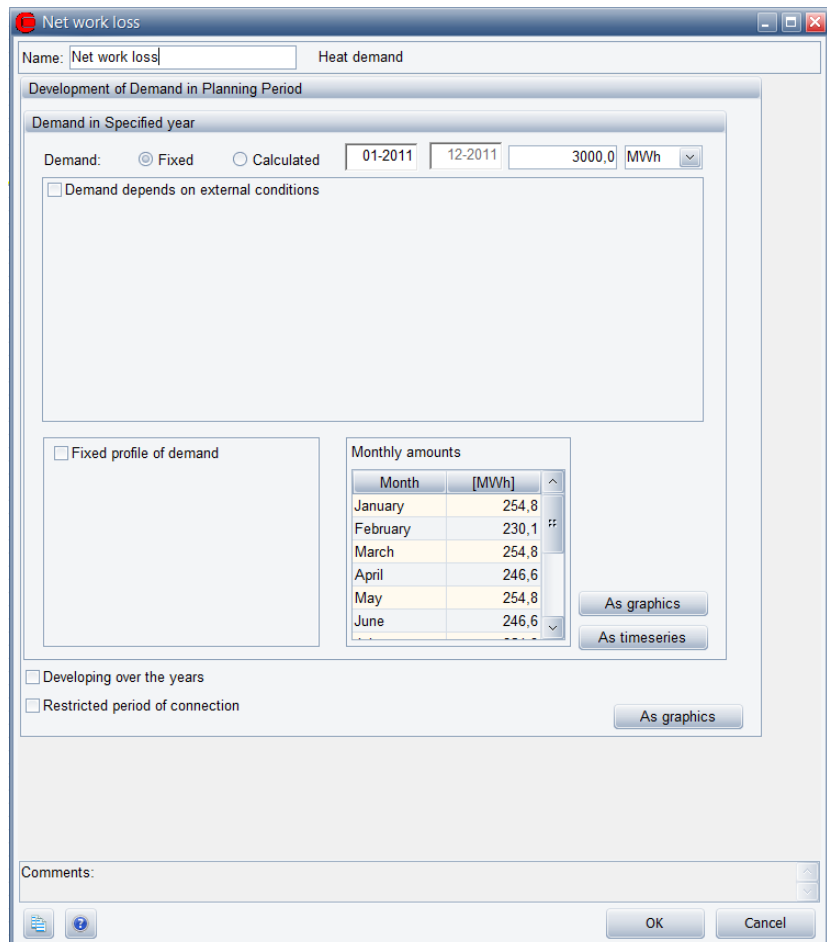

Figure 2.38: Demand – simple. Demand is fixed

There are several opportunities to design a demand in a way that it reflect daily, weekly, monthly, and annual variations (see later).

Demand is calculated

In this case the only number to be specified is the independent demand in MW. In this case the annual demand input field is dimmed and show the calculated annual demand in the figure below 3000 MWh.

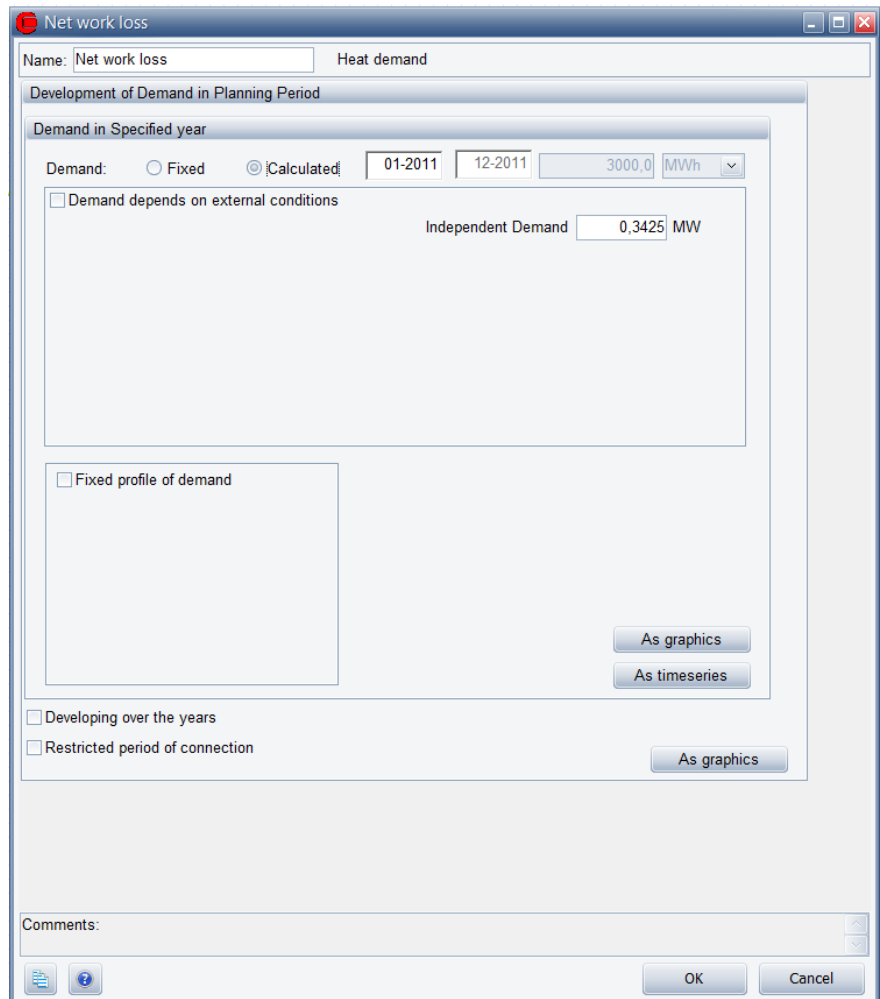

Figure 2.39: Demand – simple. Demand is calculate

The button “As graphics” gives access to view your input graphically. Correspondently the button “As time series” shows the input converted into a time series.

2.8.2 Demand depends on external conditions

Often the demands or parts hereof are dependent on external conditions, most often ambient temperatures. If “Demand depends on external conditions” is marked, a set of options to set will appear. This is shown in Figure 2.40. The options consist of three parts.

- Dependent fraction/dependent demand
- Season for dependent demand
- Formula for dependency

The figure shows two screenshots of the 'Demand in Specified year' dialog box. The top screenshot shows 'Demand' set to 'Fixed' with a value of 12000,0 MWh. The bottom screenshot shows 'Demand' set to 'Calculated' with a value of 12000,0 MWh. Both screenshots show 'Demand depends on external conditions' checked, with a dependent fraction of 80,0% and a restricted season from 01-09 to 31-05. The formula for dependency is 0,1544 * Max(17-T, 0) + 0,2740.

Figure 2.40: Demand depends on external conditions. Upper picture: demand is fixed. Lower Picture. Demand is calculated

“Demand depends on external conditions” is marked by default when a Heat demand is created but unmarked when other demand types are created.

IMPORTANT: Require time series or time series functions created under the external conditions

IMPORTANT: The use of “Demand depends on external conditions” requires that a time series or a time series function containing the external conditions have been established. The time series is normally a time series containing the average ambient temperature day by day during a year.

Dependent fraction /dependent demand

Fixed demand: First, you have to define the fraction of the demand that is weather dependent. In a district heating system for instance 20 % of the heat might be assumed to be heat losses because of transmission and distribution pipes and another 20 % to be used for domestic hot water, leaving 60 % for space heating. These 60 % normally depend on the ambient temperature.

Calculated demand: If calculated demand is selected then a part dependent on external conditions (in MW/<unit>) and a constant part have to be specified (in MW). In this case the annual demand input field is dimmed and show the calculated annual demand as shown in the figure above lower part is 12000 MWh.

Restricted Season for dependent demand

You have the option to define the “Restricted season for dependent demand” by typing in the first date of the restricted season followed by the last day of the heating season, see Figure 2.40.

Formula for dependency

There are two ways of defining formula for dependency. The first option is that the demand “Depends linear on ambient temperature”. The second option is choosing “Is user defined”.

Depends on linear ambient temperature

Demands are distributed after a simple degree-day method. The reference temperature and a time series containing ambient temperatures have to be typed in or chosen. Based hereupon a formula is auto-generated. In the figure below, the user has chosen 17°C as reference temperature and chosen the time series with the symbol “T”.

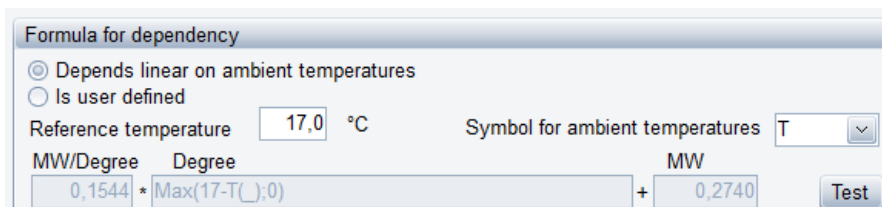

Formula for dependency

Depends linear on ambient temperatures
 Is user defined

Reference temperature °C Symbol for ambient temperatures

MW/Degree Degree MW

* +

Figure 2.41: Formula for dependency - degree-day distributed heat demand

Symbol for ambient temperature. In the symbol for ambient temperature combo-box, you find all the symbols attached to the time series and time series functions included in the “External conditions”-folder. Select the symbol used in the time series containing your ambient temperatures, in the figure “T”.

Reference temperature. The reference temperature is the ambient temperature below which room heating is needed. In Denmark, this temperature is normally assumed to be 17 °C.

Formula. When “Depend linear on ambient temperatures” is chosen the formula field is dimmed and not editable. In the formula field, you see the degree-day formula, including the reference temperature and the symbol for the ambient temperature. The whole formula expression consists of three parts. First part is a factor to be multiplied with the degree-day formula (part two) and finally the constant part. If fixed demand is chosen the first and third part is calculated. If the demand is specified the first and third part of the formula expression is taken from the values stated above (as dependent demand and independent demand).

Short explanation of the used degree-day method. If e.g. the reference temperature is 17 °C, with an ambient temperature one day on 12 °C and another day an average temperature on 7 °C, there will be 17°C-12°C=5 degree days in the first day and 17°C-7°C=10 degree days in the second day. That means that the first day only gets half of the amount of ambient dependent heat demand as the second day.

Is user defined

If “Is user defined” is chosen the options for setting the reference temperature and the ambient temperature is no longer available.

Formula for dependency

Depends linear on ambient temperatures
 Is user defined

MW/Unit Unit MW
 0,1544 * Max(17,0-T(_):0) + 0,2740 fx Test

Figure 2.42: Formula for dependency – Is user defined

The only option is to define the formula. In the formula shown in Figure 2.42 is shown a degree-dependent formula, assuming T is the symbol for a Time series holding ambient temperatures. In chapter 4 “Functions in energyPRO” you find a detailed description of the function to be used in energyPRO.

Fixed profile of demand

Demands do often vary systematically on daily or weekly basis. Checking “Fixed profile demand” and marking one of the two radio-buttons “Daily” or “Weekly” enables options for modelling this. In Figure 2.43 is shown an example, where weekly is chosen.

A fixed profile of demand consists of a number of rows each described by a time and a ratio.

Fixed profile of demand

Daily Weekly

	Day	Time	Ratio
1	Monday	00:00	6,0
2	Monday	06:00	10,0
3	Monday	18:00	6,0
4	Tuesdav	06:00	10,0

Figure 2.43: Fixed profile of demand. Weekly cycle

You can add and delete lines by pressing the “add line” and “Delete line”- buttons. If you choose the “As graphics”-button, you will see a graphical representation of your time cycle. Figure 2.44 shows an example of the variation of a weekly cycle.

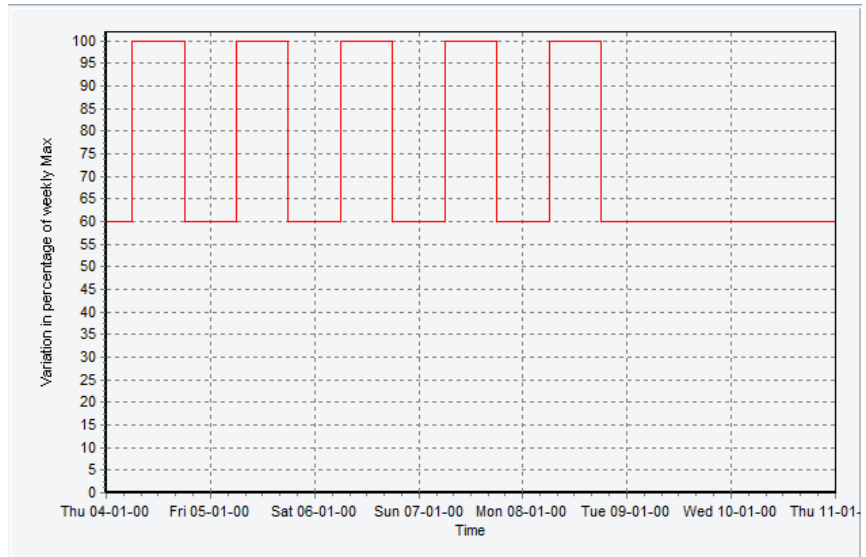

Figure 2.44: Demand - Weekly cycle – graphic. Variations in percentage of weekly max.

Note that this graphic only shows the variation of the time cycle and NOT the variation of the demand.

2.8.3 Developing over the years

It is possible to design a demand that is developing over the years, see figure below. This is done by marking the field “Developing over the years”, and link to an already created “Index”. All the Indexes in the “External conditions folder” in your project are available the in the combo box. For further information about creating Indexes please refer to External conditions - Indexes

Developing over the years Heat demand index ▾
 Restricted period of connection As graphics

Figure 2.45: Demand – developing of the years

2.8.4 Restricted period of connection

Another option is to restrict the period of connection. If you for instance want to model that a new demand will emerge next year you have the opportunity to mark the field “Restricted period of connection” and to type in the period in which the demand is present, see figure below. If the restricted period of connection is not specified it is assumed that the demand is connected in the whole planning period.

Developing over the years
 Restricted period of connection 01-01-2012 ▾ - 31-12-2012 ▾ As graphics

Figure 2.46: Demand – Restricted period of connection

2.8.5 As graphics – button

To see a graphical representation of the demand you have to press the “As graphics”-button placed in the right side of the editing window. In Figure 2.47 a graphical example of a demand is shown.

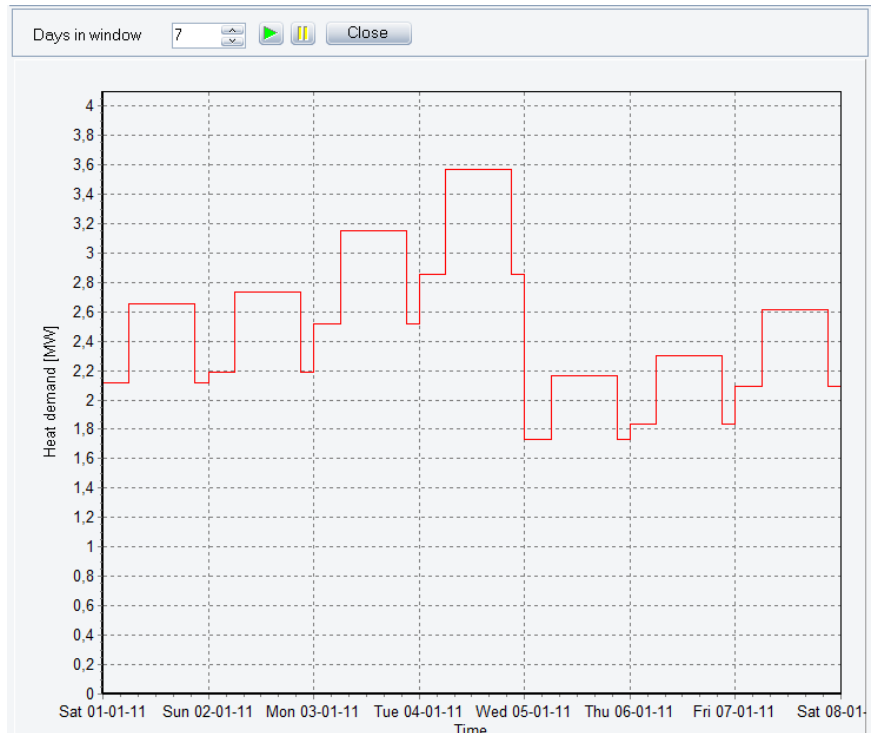

Figure 2.47: A demand shown as graphics example

2.8.6 As time series – button

After having created a new demand, you can right click this demand and select “Convert to time series”. Here the demand specified so far will be converted to a time series. This time series can then be edited as described in the section External conditions - Time series.

Internally within energyPRO all demands are converted to this format, before energy calculations are started.

2.9 Energy conversion units

2.9.1 Energy conversion units – in general

There are two types of energy conversion units in energyPRO. Those are

- Production units
- Heat rejection

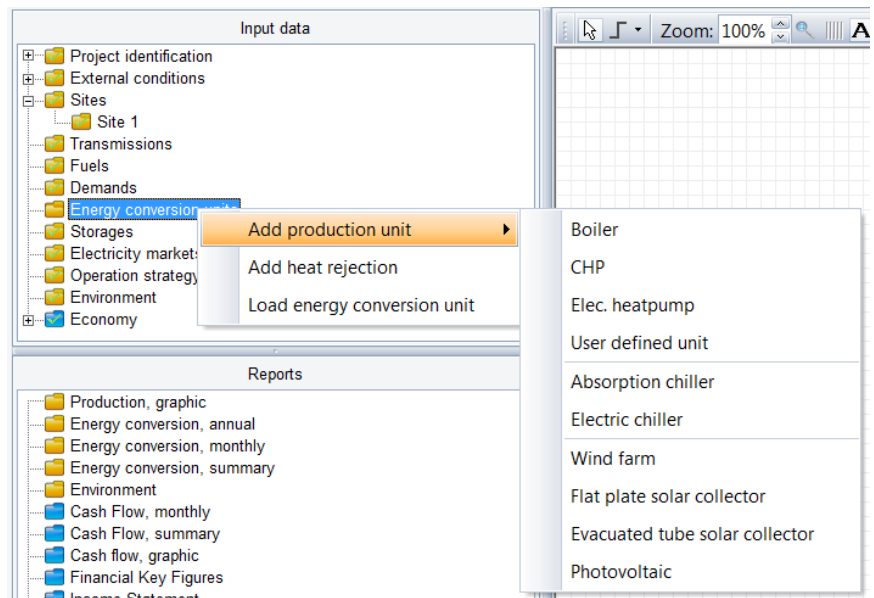

Figure 2.48: The types of energy conversion units in energyPRO

The production units consists of ten predefined types of units of which one is a user defined type described by load curve(s) and four renewable technologies described with individual editing windows. The Load curve described units are:

- Boiler
- CHP-unit (Combined Heat and Power)
- Electrical heat pump
- User defined unit
- Absorption Chiller
- Electrical Chiller

If the production unit type is consuming (or producing) fuel, a fuel defined in a “fuel” sub-folder has to be selected.

The ability to convert energy is described with one or more load curves. Each load curve contains two or more loads, depending on the type of unit. The user-defined unit include all load types except “Heat consumption”. The possible loads are:

- Fuel consumption
- Heat production
- Heat consumption
- Electric production
- Electric consumption
- Heat consumption (only available in absorption cooling)
- Cooling production
- Fuel production

For advanced users there is a wide scope of options to describe the behaviour of energy units dependent on formulas, the actual production on other production units and time series specified in the “External condition”- folders.

The special treated renewable technologies without load curve description are:

- Wind farm
- Flat plate solar collector
- Evacuated tube solar collector
- Photovoltaic

2.9.2 Production units described by load curves

Figure 2.49 shows an example of a production unit, in this case a CHP-plant, fuelled with natural gas.

The screenshot shows the configuration window for a production unit named "Gas engine 1". The settings are as follows:

- Name: Gas engine 1
- Production unit type: CHP
- Fuel: Natural gas
- Powerunit: kW
- Min. Operation time (Hours): 2
- Non availability periods: (checked)

Start Time	End Time	Every Year
09-01-2012	17-01-2012	<input checked="" type="checkbox"/>
01-02-2012	09-02-2012	<input checked="" type="checkbox"/>

Operation	Fuel	Heat	Elec. power
		kW	kW
Max.	5267,0	2114,0	2000,0
Min.	2634,0	1057,0	1000,0

Additional options: Operation dependent on other unit, Enable formulas in power curve.

Figure 2.49: Production unit – CHP example

Production unit type

Figure 2.50 show the available energy units specified by power curves in energyPRO.

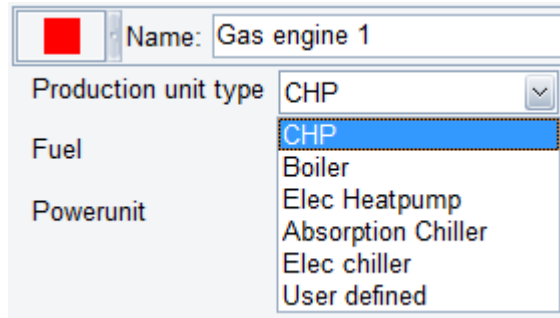

Figure 2.50: Production unit types

Depending on the production unit type selected, two or more power curves are available. Table 2.1 shows the power curves available depending on the selected Production unit type.

	Fuel consumption	Heat consumption	Electricity consumption	Heat production	Process heat production	Electricity production	Cooling production	Fuel production
CHP	X			X	X	X		
Boiler	X			X	X			
Electrical heat pump			X	X				
Absorption cooling		X					X	
Electrical cooling			X				X	
User defined	X		X	X	X	X	X	X

Table 2.1: Available power curves for the different types of energy units

Note that Process heat production is only available if the “Delivery of both heat and process heat” is selected in the “Advanced” setting in the “Project Identification” editing window. Fuel production is only available if “Fuel producing energy units in project” has been chosen in the “Project Identification”.

Fuel type

Only fuels added in the fuel folder are available

Select a fuel in the combo-box. Options are the fuels you have added in your Fuel folder.

If “Fuel producing energy units in project” has been ticked in the “Project Identification” then a dropdown box called “Fuel output” is added between the fuel input dropdown box and the Powerunit dropdown box.

Power unit

Select the power unit, which you will use in the power curves. Options are kW and MW.

Power curve

The top line state the maximum loads, while the bottom line states the minimum loads of the energy unit. The loads of the energy unit between the power lines are calculated by linear interpolation. Note that if only one line is stated then a second imaginary line is automatically assumed created with the content of zeroes.

Enable formulas in power curves:

This facility gives access to adding formulas in the power curves instead of numbers. The formula will in each time step of the calculation call the formula and return a value.

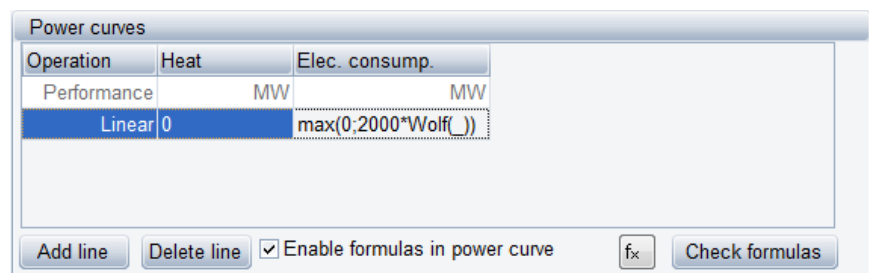

Figure 2.51: Power curve, formula enabled example

Note that you can use all the time series created under external conditions and demands you have defined.

For instance, you can make the power curve depend on the ambient temperature. If the symbol for ambient temperature is T, it is referenced by T(_), where the underscore means the value belonging to the time step calculated.

You have the option to define load curves, including

- External conditions. For instance temperature time series
- Demands
- Production on other production units
- Mathematical standard operators

In chapter 4 “Functions in energyPRO” is found a detailed description of the functions to be used in energyPRO.

Note: The use of formulas in your power curves will normally increase the calculation time considerably.

The use of formulas will normally increase the calculation time considerably

Figure 2.51 shows an example where time series are used for modelling the electricity production from off shore wind turbines. Here 2000 MW

multiplied with a time series representing a normalized 1 MW-production profile.

Function-button

When you push this button a text window will appear. Here you can see the available functions and eventually copy and paste them to the power curve. There are three groups of functions. External conditions, demand functions and other functions. The first two references respectively to time series created under external conditions and to the demands. The last group contain basic mathematical functions and a step-function Z.

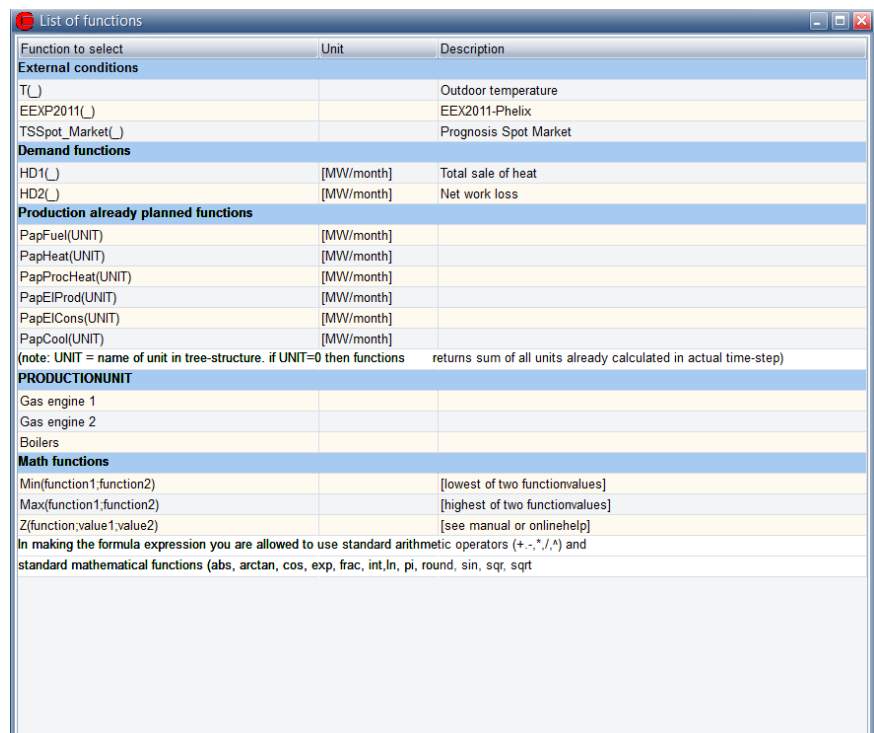

Figure 2.52: Example of list of functions

Restricted period of connection: Checking this option gives access to state the period where the unit exist. No specification means that the unit exist in the whole planning period.

Operation dependent on other unit: With this option checked you can state whether operation on this unit either include or exclude operation on another unit. This choice will appear at the bottom of the window as the choices:

- Allowed only when no production on unit
- Allowed only when production on unit.

In both cases, you have the option to specify one of your already created energy units by selecting them in the two combo-boxes

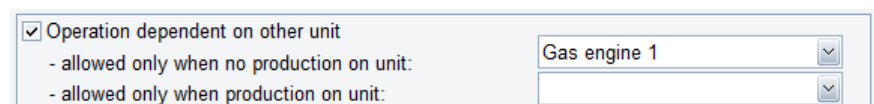

Figure 2.53: Operation dependent on other unit

Below is given two examples of how to use this facility.

If you e.g. have an energy unit running on two different fuels, biogas and natural gas, you can define this energy production unit as consisting of two different energy units (biogas engine and natural gas engine). You select the unit you are specifying, e.g. the natural gas engine part is not allowed to run if the biogas engine is already operating.

If you e.g. have an energy unit where you can add an economizer to improve its heat production power output, you can define the economizer as an extra energy unit (modelled as boiler). When selected, the economizer can only be in operation if the belonging energy unit is producing. You then select the unit that have to be operating at the same time as the actual unit that you are editing.

If no energy unit is selected, no restrictions are imposed on the operation.

Non-availability periods: By checking the “Non availability periods”, you get access to a table where you can specify periods, where the actual energy unit is not available for operation. This could for instance be if the unit in a period is out for scheduled maintenance.

It is possible to define the non availability periods by adding lines stating the occurrences. The possible occurrences are

- Once
- Yearly
- Monthly
- Weekly
- Daily

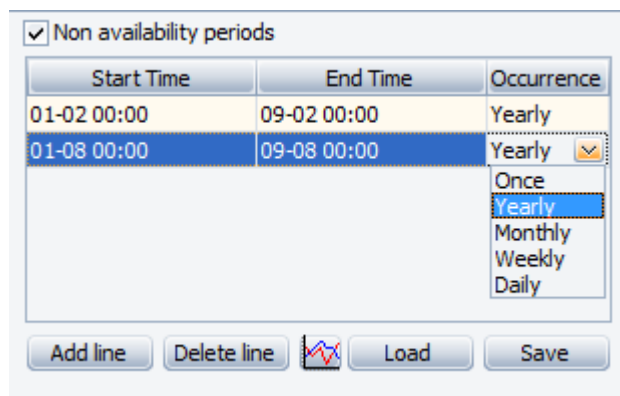

Figure 2.54: Non availability periods. Occurrence options

The figure below shows an example where this is the case 8 days in respectively February and August.

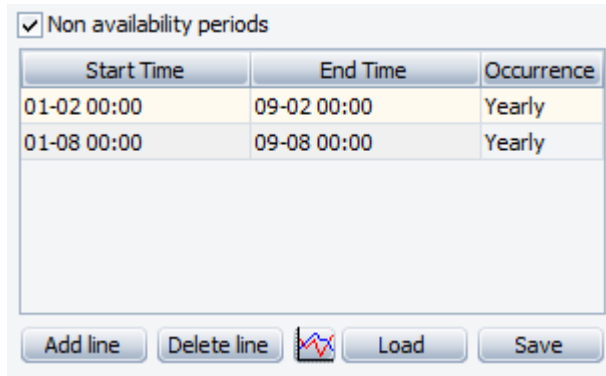

Figure 2.55: Non availability periods

It is possible to construct the non availability periods by adding lines using a random mix of occurrences (once, daily etc.)

2.9.3 Production units not described with load curves

Flat plate solar collector and Evacuated tube solar collector

In energyPRO Solar collectors are described by a) Size and position, b) Time series with ambient temperatures and solar radiation and c) Collector and field specific information, see Figure 2.56.

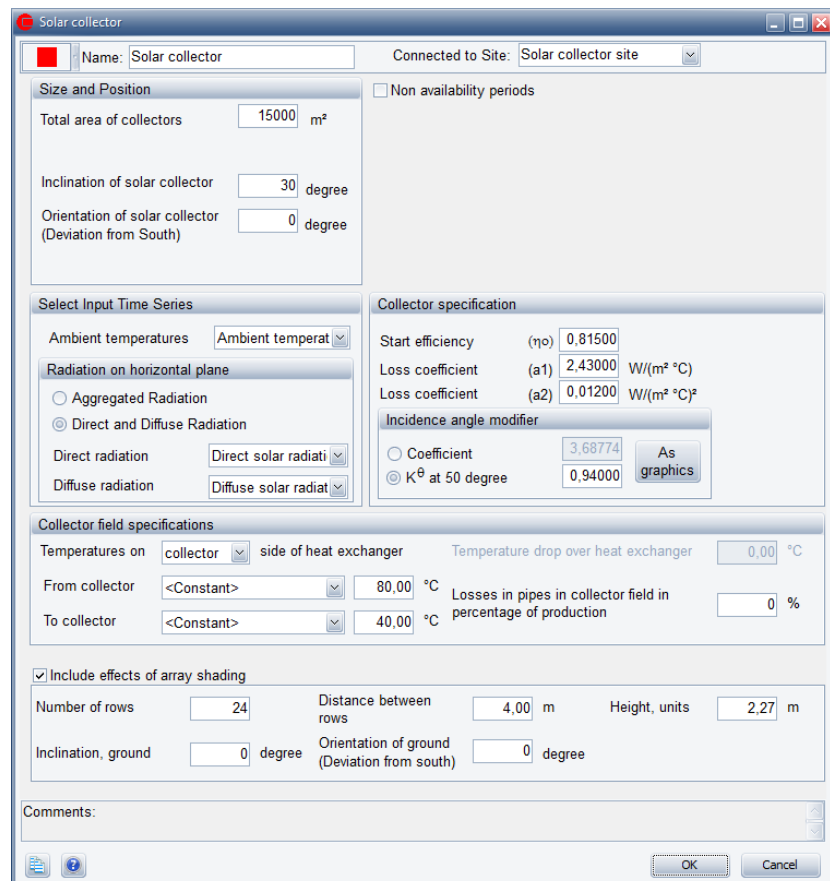

Figure 2.56: Flat plate solar collector editing window in energyPRO

Size and Position

Total area of collectors: Is the aggregated area of the solar collectors.

Inclination of solar collector: This is the tilted angle from ground of the solar collector.

Orientation of solar collector: The orientation of the solar collector is the deviation of the collectors from facing south (northern hemisphere – otherwise deviation from north).

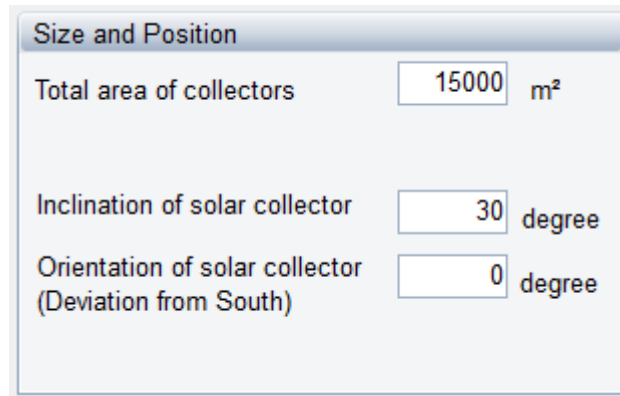

Size and Position	
Total area of collectors	15000 m ²
Inclination of solar collector	30 degree
Orientation of solar collector (Deviation from South)	0 degree

Figure 2.57: Solar collector – Size and position

Select Input Time Series

Prerequisites for the calculation of the heat production are time series with ambient temperatures and solar radiation on the horizontal plane.

These time series must be placed in the “External conditions”- folder before modelling the solar collector.

Ambient temperature: Select a time series holding ambient temperatures.

Radiation on horizontal plane: Depending on the available data solar radiation data two options are available. If “Aggregated” solar radiation is available, then select “Aggregated radiation” and select the time series holding these data. If both “Direct” and “Diffuse” is available then select the two time series holding these data, see Figure 2.58

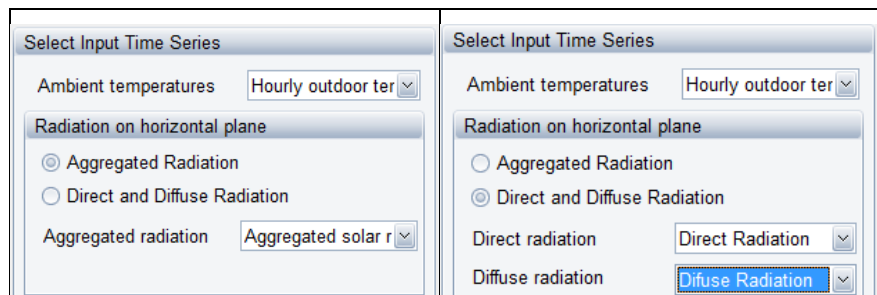

Select Input Time Series	
Ambient temperatures	Hourly outdoor ter
Radiation on horizontal plane	
<input checked="" type="radio"/> Aggregated Radiation	
<input type="radio"/> Direct and Diffuse Radiation	
Aggregated radiation	Aggregated solar r

Select Input Time Series	
Ambient temperatures	Hourly outdoor ter
Radiation on horizontal plane	
<input type="radio"/> Aggregated Radiation	
<input checked="" type="radio"/> Direct and Diffuse Radiation	
Direct radiation	Direct Radiation
Diffuse radiation	Difuse Radiation

Figure 2.58: Solar collector – Select input time series

For correct calculation of the angle of incidence of beam radiation on the inclined surface and correct correlation between the angle of incidence and the solar radiation, it is important that the location of the time series is specified correct.

This is set in the time series with the solar radiation.

If location is not defined, you will have an error warning. The latitude and longitude are specified in decimal degrees. The latitude has positive values north of equator and negative values south of equator. The longitude has positive values east of Greenwich Mean Time (UTC) and negative values west of Greenwich Mean Time.

Collector and field specification

The solar collectors are specified by a number of values, defining their technical characteristics. These values are normally found in the data sheets from the manufacturers.

The equation used for the calculations are

$$P = A * (I * \eta_o - a_1 * (t_m - t_a) - a_2 * (t_m - t_a)^2) * L_p$$

where

I = Calculated radiation based on the position and radiation time series.

t_a = Ambient Temperatures found in specified time series.

η_o = Start efficiency: Start efficiency is also called “Conversion factor”. The collectors start efficiency, where the fluid temperature equals the ambient temperature.

a_1 = Loss coefficient (a1)

a_2 = Loss coefficient (a2)

Collector specification			
Start efficiency	(η_o)	0,81500	
Loss coefficient	(a1)	2,43000	W/(m² °C)
Loss coefficient	(a2)	0,01200	W/(m² °C)²
Incidence angle modifier			
<input checked="" type="radio"/>	Coefficient	4,00000	As
<input type="radio"/>	K $^\theta$ at 50 degree	0,95272	graphics

Figure 2.59: Flat plate solar collector – Collector specification

Incidence angle modifier (K_θ): Refers to the change in performance as the sun's angle in relation to the collector surface changes. The IAM is used for the calculation of I , found in the equation above.



Figure 2.60: Flat plate solar collector – Incidence angle modifier as graphic

The Evacuated Tube Solar Collector differs from the flat plate solar collector when it comes to the Incidence Angle modifier:

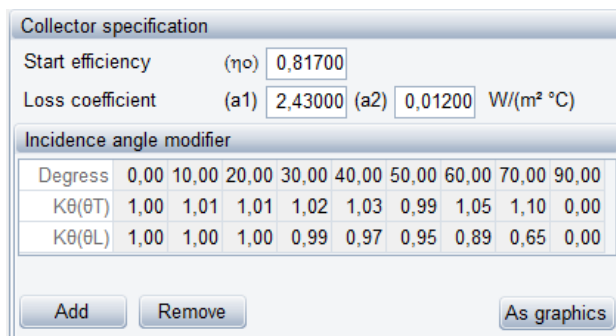

Figure 2.61: Evacuated tube solar collector – Collector specification

Evacuated tube collectors are optically non-symmetric. The incidence angle modifier is divided into a longitude and transversal IAM. The above values look like this as graphic:

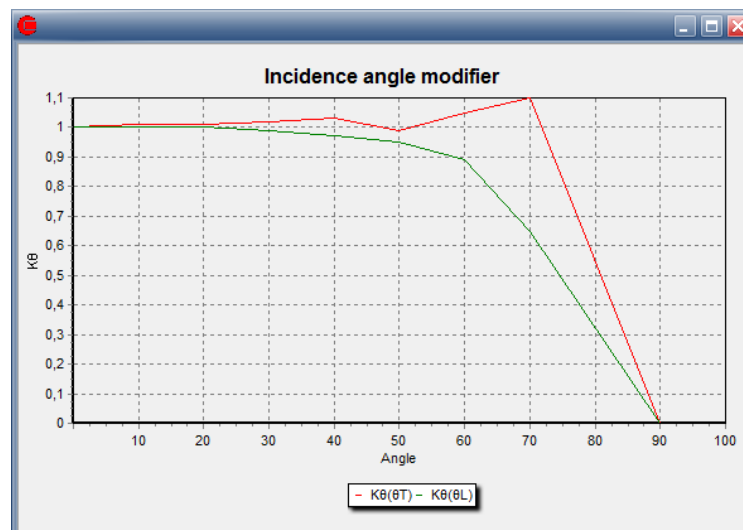

Figure 2.62: Evacuated tube solar collector – Incidence angle modifier as graphic

t_m = Collector temperature: The average temperature of the collectors on the collector side. This temperature is defined by a forward

temperature (the temperature of the water leaving the collector), t_{from} and a return temperature (the temperature of the water entering the collector), t_{to} . These values can either be fixed or referring to an external time series. Most often these temperatures are known on the demand side of the heat exchanger, but in the calculations it is the temperature on the collector side of the heat exchanger that is needed. So if you know the temperature on the demand side you can select that in the user interface and then you also have to specify the temperature drop over the heat exchanger, t_{hx} . The complete equation for calculating t_m is then:

$$t_m = (t_{from} + t_{to}) / 2 + t_{hx}$$

Collector field specifications			
Temperatures on	collector	side of heat exchanger	Temperature drop over heat exchanger
From collector	<Constant>	70,00 °C	Losses in pipes in collector field in percentage of production
To collector	<Constant>	35,00 °C	0 %

Figure 2.63: The Collector field specification window used to define temperatures and losses

$L_p =$ Losses in pipes: This represents the loss in the pipes in the collector field. The loss is simply given as a percentage of the heat production.

Array shading

Often, large scale solar collector or photo voltaic systems will be mounted on the ground in rows which results in array shading. In other words solar collectors in one row will produce shade on the row behind it (compared to the sun). In energyPRO the effect of array shading is included by specifying the following parameters:

Include effects of array shading			
Number of rows	1	Distance between rows	1,00 m
Inclination, ground	0 degree	Height, units	1,00 m
		Orientation of ground (Deviation from south)	0 degree

Figure 2.64: The array shading parameters

- **Number of rows:** The number of rows in the array
- **Distance between rows:** The distance in meters between each row
- **Height, units:** The height of each solar collector in meters
- **Inclination, ground:** The inclination of the ground in degrees. 0 means a flat surface.
- **Orientation of ground:** The orientation of the ground relative to directly south.

These parameters are used to calculate the effect of array shading on direct (beam), diffuse and reflected radiation.

Photovoltaic

In energyPRO solar Photovoltaic is described by a) Size and position, b) Time series with ambient temperatures and solar radiation and c) a PV module specific information, and d) Miscellaneous, see Figure 2.65.

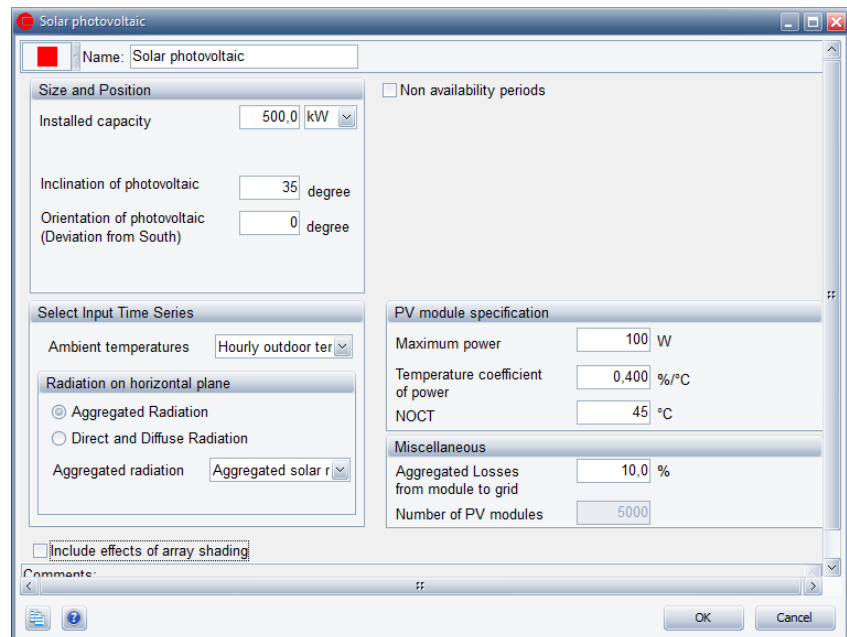

Figure 2.65: Photo Voltaic editing window in energyPRO

Size and Position

Total Installed capacity: Is the aggregated capacity of installed PV panels, the unit is stated in kW or MW.

Latitude UTM: Is the Latitude of the Photovoltaic in UTM coordinates.

Inclination of photovoltaic: This is the tilted angle from ground of the PV panels.

Orientation of photovoltaic: The orientation of the photovoltaic is the deviation of the PV panels from facing south (northern hemisphere – otherwise deviation from north).

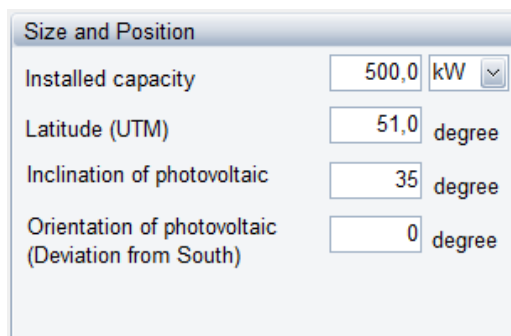

Figure 2.66: Photovoltaic – Size and position

Select Input Time Series

Prerequisites for the calculation of the heat production are time series with ambient temperatures and solar radiation on the horizontal plane.

These time series must be placed in the “External conditions”- folder before modelling the photovoltaic.

Ambient temperature: Select a time series holding ambient temperatures.

Radiation on horizontal plane: Depending on the available solar radiation data two options are available. If “Aggregated” solar radiation is available, then select “Aggregated radiation” and select the time series holding these data. If both “Direct” and “Diffuse” is available then select the two time series holding these data, see Figure 2.67.

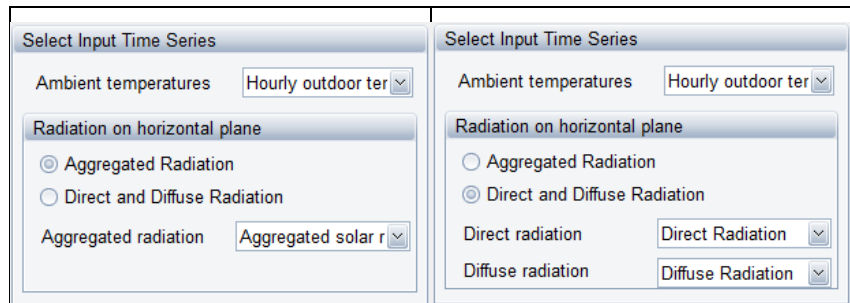

Figure 2.67: Photo Voltaic – Select input time series

PV module specification

The PV module is described by three parameters, normally found on the manufacturers’ data sheets.

Maximum power: The “Maximum power” from the PV panel under standard conditions. This value is not used in the energy conversion but only to calculate the number of panels.

Temperature coefficient of power: This coefficient specifies how the power productions from the panels react to changes operating temperature.

NOCT: Normal Operating Cell Temperature

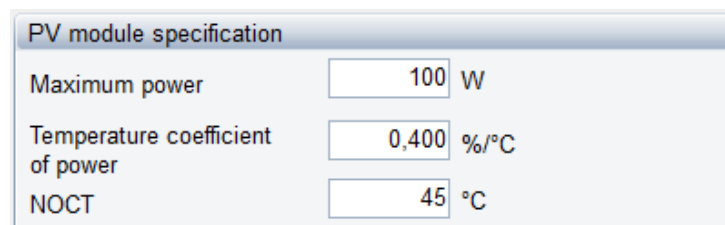

Figure 2.68: Photo Voltaic – PV module specification

Miscellaneous

Aggregated losses from module to grid: This value represents the losses from module to grid and encompasses PV array losses, cable losses, inverter losses etc.

Number of values: The calculated number of panels based on installed capacity and the Maximum power from the PV module specification.

Miscellaneous	
Aggregated Losses from module to grid	10,0 %
Number of PV modules	5000

Figure 2.69: Photo Voltaic – Miscellaneous

Wind farm

The wind farm is a specialised energy unit having the general energy unit properties such as “non availability periods”, the “operation dependent on other unit”-option and the “restricted to period”-option.

The wind farm uses an external time series with measured wind speed and a wind farm power curve to calculate electric production from the wind farm. The time series with wind speed must be present in the “External conditions”-folder, and the power curve must be specified in the wind farm editing window.

Calculation type

There are two approaches for calculation of wind farms in energyPRO.

1. Annual production calculated, divided into two sub cases
 - a. Park power curve is used directly
 - b. Power curve is scaled to another level
2. Fixed annual production (wind speed is scaled)

All approaches require that a time series holding wind speed is available and present in the “External conditions”-folder.

Calculation type	
<input type="radio"/>	Annual production calculated
<input checked="" type="radio"/>	Fixed annual production

Figure 2.70: Calculation type

Annual production calculated. In this case the productions from the wind farm are calculated based on the wind speed specification and power curve of the wind farm. As an advanced setting, there are options to scale the power curve and thereby the production.

Fixed annual production. This option serves to distribute a desired annual production given a specified wind farm power curve. All wind speeds specified through “Wind speed specification” (see below) are scaled by the modification factor that makes agreement between the annual production, the power curve and the wind speeds. This factor is found through iterations.

Wind speed specification

The wind speed at hub height is defined through the following parameters, which is used for converting the wind speed in measure height to wind speed at hub height.

1. A time series holding the wind speed
2. The measure height of the time series
3. The hub height of the turbines
4. The Hellmann exponent

Figure 2.71: Wind speed specification

Ad 1) The time series must be established in “External conditions” prior to the specification.

Specification of power curve

The power curve consists of a data set of values containing the wind speed and the corresponding power output from the turbines. In the calculation, the power output is assumed to be linear between two data elements. The power curve is specified through a data table and shown on a corresponding graph, see Figure 2.72.

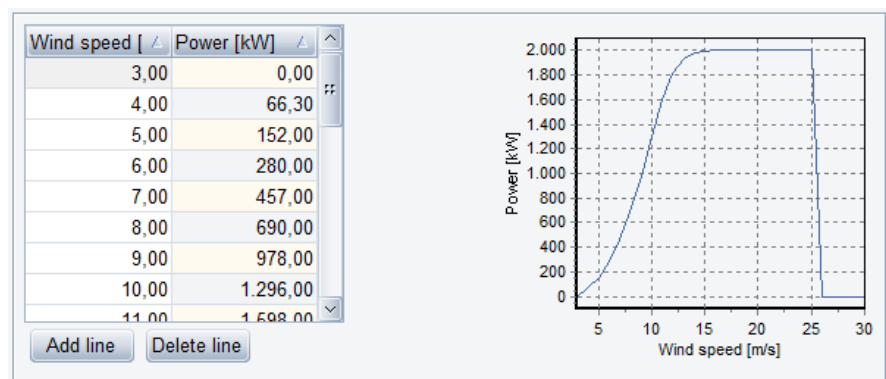

Figure 2.72: The power curve of the wind farm

The functionalities of the table are comparable to the other energyPRO tables. This includes unlimited number of values, add line and delete line buttons. Data is added by typing data into the table or it can be pasted via the clipboard. It is possible to copy a calculated wind park curve from WindPro[®] via clipboard to the wind farm power curve in energyPRO, see Figure 2.73.

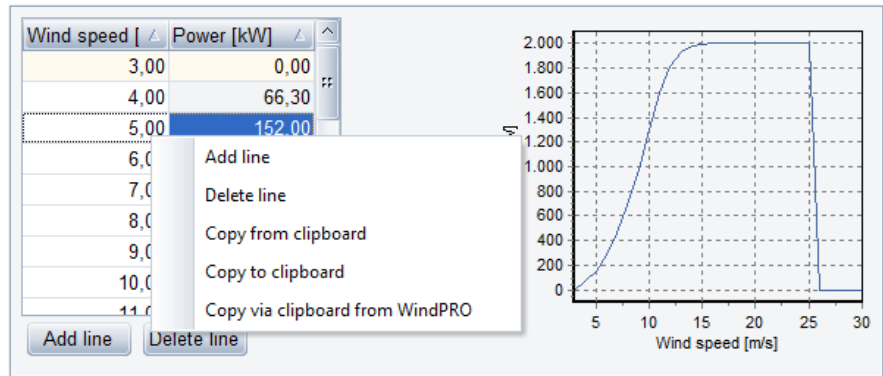

Figure 2.73: The power curve. Values can be copied from clipboard, including park power curve calculated in WindPRO

Figure 2.74 shows the content of the wind farm editing-window if “Annual production calculated” is selected.

This window contains the data described in this window, plus an advanced option.

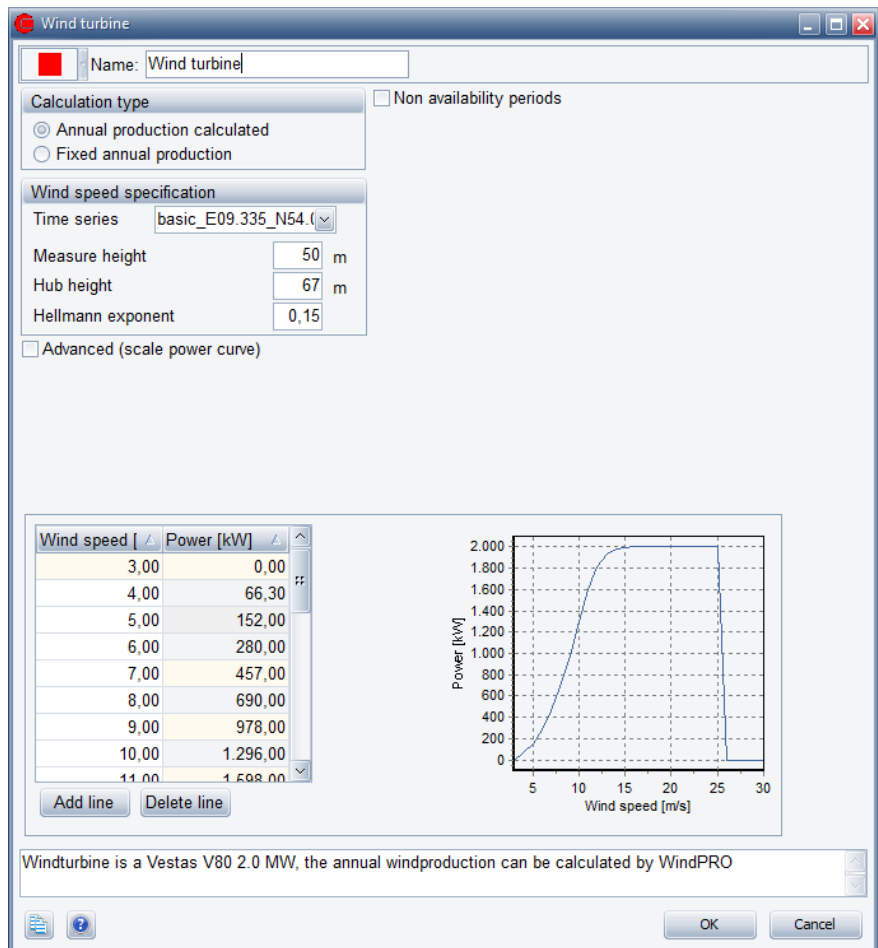

Figure 2.74: Wind farm, “Annual production calculated”, not advanced

Annual production calculated (power curve scaled).

An example of this is shown in Figure 2.75. Notice that the power curve now has a new resulting power curve both in the table presentation and in the graphic representation. There are two variants. It is possible to

scale using a percentage or a new max. power curve value, see Figure 2.75 and Figure 2.76.

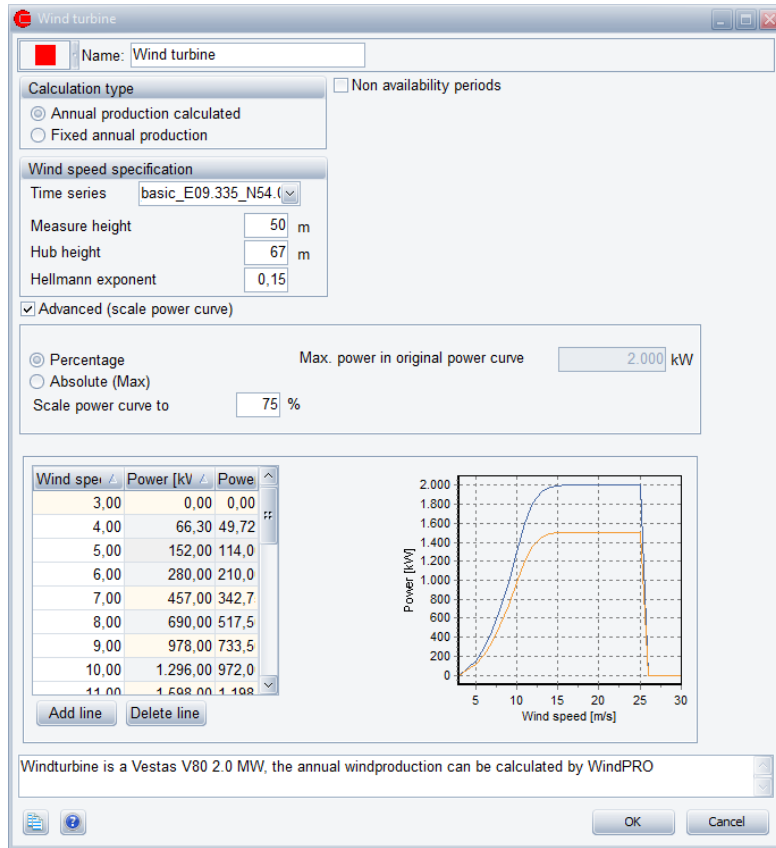

Figure 2.75: Wind farm, "Annual production calculated", power curve scaled with percentage

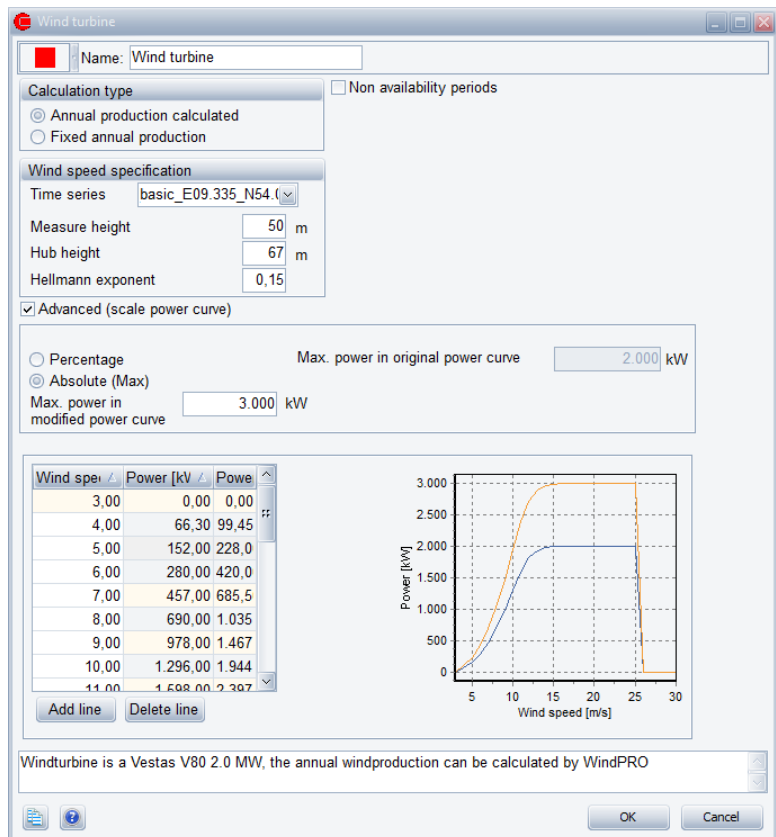

Figure 2.76: Wind farm, "Annual production calculated", power curve scaled with max power curve value

Fixed Annual production

If Fixed annual production is selected then the Annual production and the wind farm power curve is specified (e.g. calculated in WindPro). Given the power curve and a stated annual production all wind speed values are scaled by a factor. This factor is calculated, and is used when calculating the production at any time. See the description in section 3.4.

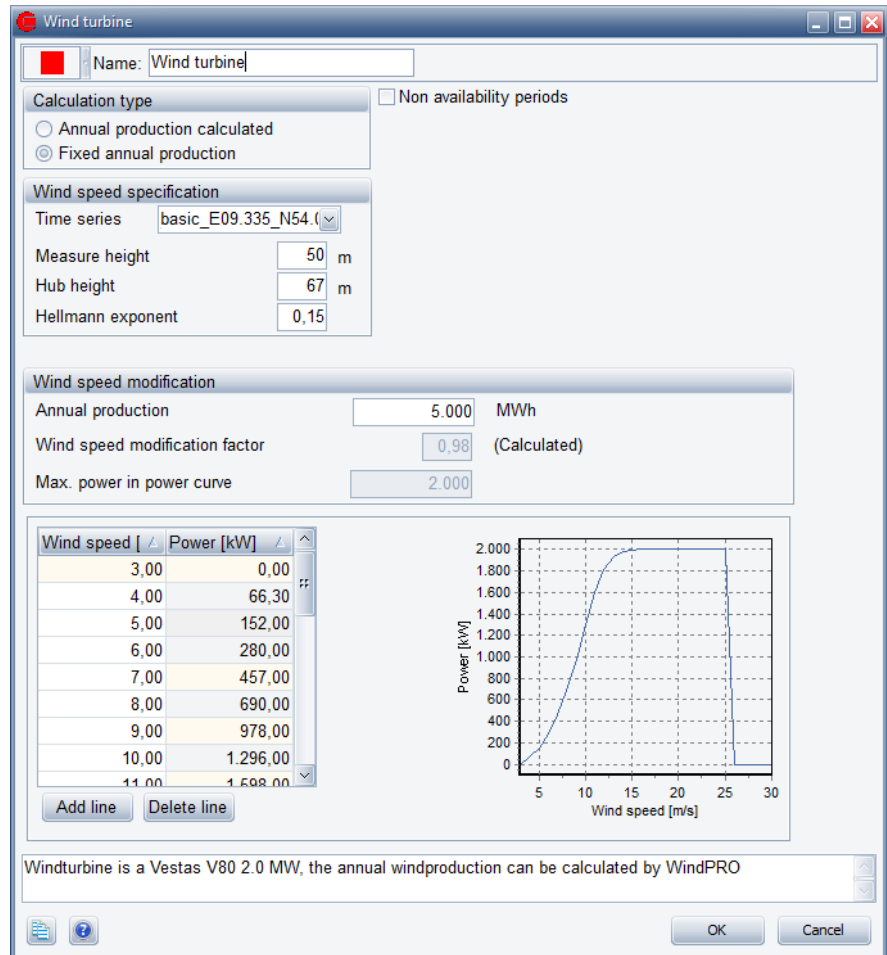

Figure 2.77: Fixed annual production (Scaling wind speed)

2.9.4 Heat rejection

A heat rejection unit is e.g. used in situations, where electricity demands require electricity production from co-generating engines, while the heat produced by the cooling of the engines cannot be utilized.

If a heat rejection unit is inserted, you must remember to select, which of the production units that have access to the heat rejection unit. This selection is done in the "Operation Strategy" editing window.

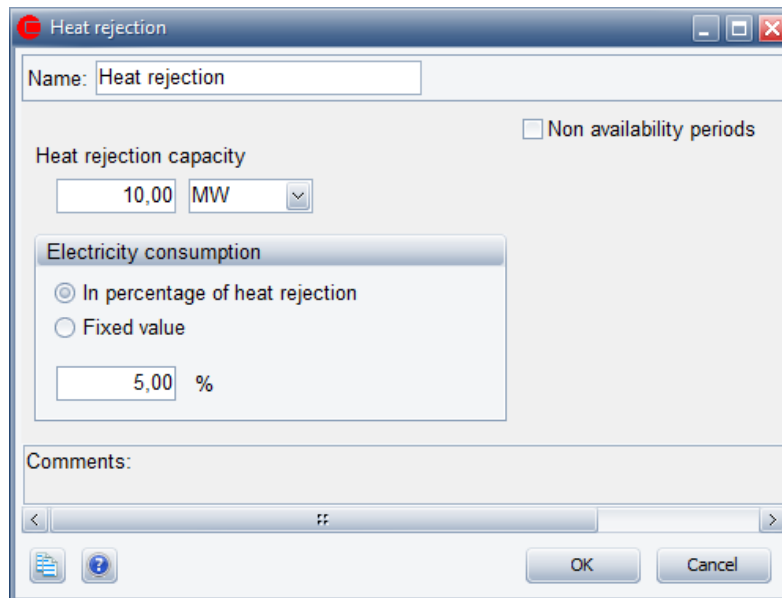

Figure 2.78: The heat rejection window

Heat rejection capacity: Here you state the heat rejection capacity.

Electricity consumption: An eventual electricity consumption can be stated either as a fixed percentage of the actual heat rejection or as a constant consumption when the unit is operated independent of the load.

Note that the heat rejection is post processed the energy conversion calculation. The consequence hereof is that there will be a residual import of electricity when demand and productions has been balanced.

Operation restricted to period: By checking this option you got access to state the period where the unit exist. No specification means that the unit exist in the whole planning period.

Non-availability periods: By checking the “Non availability periods”, you get access to a table where you can specify periods, where the actual energy unit is not available for operation.

2.10 Storages

2.10.1 Storages in general

There are three types of storages available in energyPRO. These are:

- Thermal Storage
- Electrical Storage
- Cold Storage

2.10.2 Thermal store

Thermal stores are often key elements in creating cost-effective energy systems

Energy systems do often require the use of thermal stores to reach cost-efficient solutions. Two of the main reasons are heat load situations during summertime and fluctuating electricity tariffs.

If you insert a thermal store, you must select which of the production units that have access to the store. This selection is done in the “Operation Strategy” editing window.

A thermal store also often has a loss over time that depends on the amount of energy in the storage. This loss can also be modelled in energyPRO.

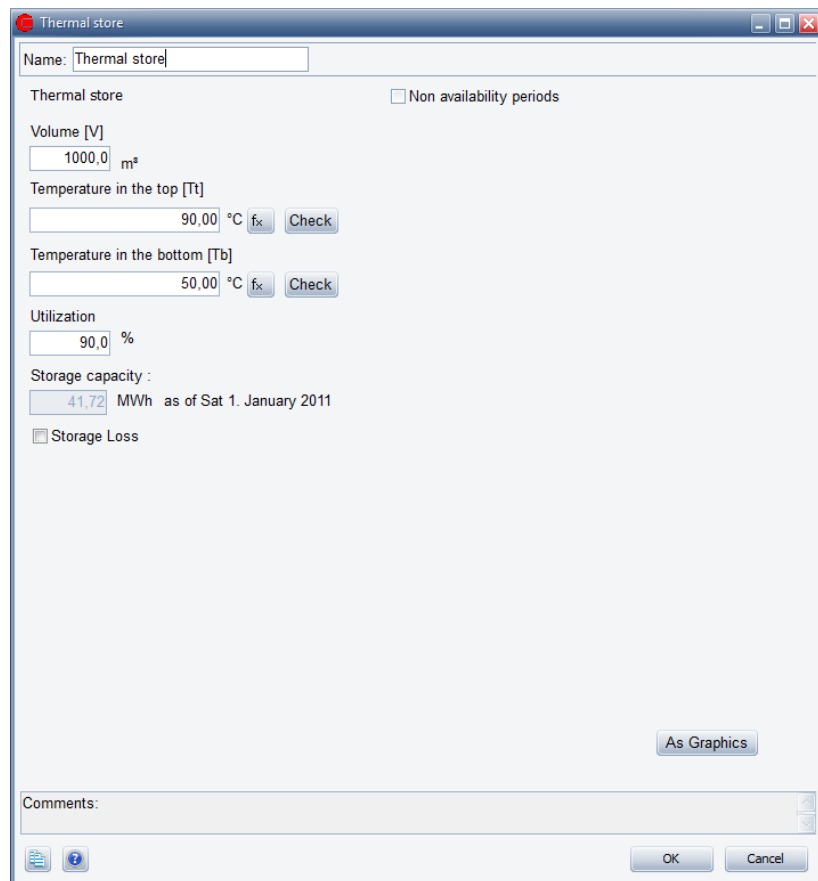

Figure 2.79: The thermal store window

Volume: Is the volume of the thermal store.

Temperature in the top: The temperature in the hot zone at the top of the thermal store. This temperature can be defined as a function using external conditions.

Temperature in the bottom: This defines the cold temperature at the bottom of the thermal store. Together with the temperature in the top this temperature is used to calculate the temperature difference.

Utilization: The percentage of the net volume actually used. The utilization might reflect both technical restrictions (e.g. volume below injection point), and operational reasons.

Storage capacity: Based on the information stated above, storage capacity is calculated and shown.

Operation restricted to period: If you are working in Finance or Accounts you have access to this point. Checking this point gives you access to state the period where the unit exists. No specification means that the unit exists in the whole planning period.

Non-availability periods: By checking the “Non availability periods”, you get access to a table where you can specify periods, where the actual energy unit is not available for operation.

Storage Loss: Clicking this check box gives you access to define a loss for the thermal store which is described in the following.

Storage Loss

In energyPRO the thermal store loss is defined by: Loss when store is full and loss when store is empty. Both these losses can vary over time, which means that they can depend on things like temperature variations in the planning period. In order to calculate the loss at a given storage content linear interpolation is used, so if the storage is 75% full the loss will be (Loss at full – Loss at empty) * 0.75 + Loss at empty.

Defining the loss at full and empty store can be a tedious task for the user so therefore energyPRO allows the user to define the loss via:

- Temperature at top and bottom (already defined as part of the thermal store capacity)
- Storage Height, which is the height of the storage in meters
- Insulation thickness in mm
- Thermal conductivity of the storage walls
- Ambient temperature, which is the temperature the storage is located in. This can be constant if the storage is located inside the building or it can be dependent on a time series if it is located outside

Storage capacity :
57,36 MWh as of Sat 1. January 2011

Storage Loss

Storage Height [h]	Insulation Thickness [s]	Thermal Conductivity [Lambda]
14,20 m	300,00 mm	0,0370 W/(m°C)

Ambient Temperature [Ta]
Outdoor temperature 20,00 °C

Formula for loss at full store User Defined MW

$$\frac{(\text{Lambda} \cdot 1000 / \text{s}) \cdot \pi \cdot \sqrt{\text{V} / (\text{h} \cdot \pi)}}{2 \cdot \text{h} + \sqrt{\text{V} / (\text{h} \cdot \pi)}} \cdot (\text{Tt}(_) - \text{Ta}(_)) / 10^6$$

Formula for loss at empty store MW

$$\frac{(\text{Lambda} \cdot 1000 / \text{s}) \cdot \pi \cdot \sqrt{\text{V} / (\text{h} \cdot \pi)}}{2 \cdot \text{h} + \sqrt{\text{V} / (\text{h} \cdot \pi)}} \cdot (\text{Tb}(_) - \text{Ta}(_)) / 10^6$$

Figure 2.80: The storage loss part of the thermal store window

Based on these attributes energyPRO will calculate the two losses, however it is also possible for the user to click the User Defined

checkbox and thereby be able to define the losses freely using functions and time series.

2.10.3 Electrical storage

In energyPRO an electrical storage is basically a storage that can store electricity by converting it to another energy type (called internal energy type). So you should think of an electrical storage as a unit that consists of three individual units; a storage unit, a charging unit and a discharging unit.

The charging unit uses electricity and converts it to the internal energy type and the discharging unit uses the internal energy type to produce electricity.

These units will have a capacity and an efficiency. The capacity indicates the amount of energy they can convert and the efficiency indicates the loss associated with converting the energy.

Battery

The simplest form of electrical storage in energyPRO is a Battery. In this type of electrical storage you can simply think of it as a battery where you only have to define the electrical capacity of the battery and the capacity and efficiency of charging and discharging units.

The screenshot shows the 'New Battery' dialog box with the following fields and values:

- Name: Battery
- Power and capacity units: MW/MWh
- Non availability periods:
- Battery section:
 - Max Capacity: 100,0 MWh
 - Utilization: 80,0 %
 - Capacity: 80,0 MWh
- Charging / Discharging section:

	Capacity	Efficiency
Charging Power	5,0 MW	85,0 %
Discharging Power	5,0 MW	85,0 %
- Operation restricted to period:

Figure 2.81: The edit window for a Battery

The actual usage of the battery in a calculation is automatically done by energyPRO to use it in the most efficient way.

Hydro pumping station

A Hydro pumping station is an electrical storage that utilizes the potential energy in elevated water. So the charging unit is a pump that uses electricity to pump water in to an upper reservoir. When electricity is needed or it makes sense to sell it, the water is let through a turbine from the upper reservoir to the lower reservoir and thereby producing electricity.

For the Hydro pumping station the electrical capacity is defined through the attributes of the two water reservoirs:

- **Height difference:** The height in meters between the two reservoirs
- **Water reservoir:** The volume of the upper reservoir in m³
- **Utilization:** The amount in percentage that can be used of the reservoir

The screenshot shows the 'Hydro pumping station' input window with the following fields and options:

- Name:** Hydro pumping station
- Storage:**
 - Height difference: 130,0 m
 - Water reservoir (Max): 1.500.000 m³
 - Utilization: 92,5 %
 - Capacity: 490,0 MWh
- Non availability periods
- Water inlet:**
 - Time series: Water from Mountain
 - Unit: m3/h
- Pumping station:**

	Capacity	Efficiency
Pumping Power	10,0 MW	82,0 %
Producing Power	10,0 MW	90,0 %
- Operation restricted to period
- Comments:** (empty text area)
- Buttons: OK, Cancel

Figure 2.82: The Hydro Pumping Station input window

Based on these attributes the electrical capacity, STcap, is calculated as follow:

$$STcap = V * \rho * g * L * u / (3,6 * 10^9) \text{ [MWh]}$$

where

V is the volume of the elevated water, m³

ρ is the density of water $\approx 1000 \text{ kg/m}^3$

g is gravity, $9,8 \text{ m/s}^2$

L is the elevation or height difference, m

u is the utilization factor in percentage

This capacity is measured according to the elevated water. The electricity output will be lower due to the efficiency of the turbine; likewise, the electricity input will be higher due to the efficiency of the pump.

The charging and discharging capacity of the hydro pumping station is set by the electric capacity of the pump and the turbine.

For a Hydro pumping station it is also possible to include a water inlet which is used to simulate water coming in to the upper reservoir. The water inlet is selected as a time series which can be either in the form of potential electrical energy (MWh) or in the form of water running to the reservoir per hour (m^3/h).

E-Cars

The E-cars electrical storage is a special kind of storage that besides the storing capability also simulates electrical car usage.

If you have a group of electrical cars you can regard them as a battery capable of storing electricity from the grid in their batteries, but also capable of producing electricity back to the grid. This is very similar to the Battery electricity storage, but two things make electrical cars special:

- **Driving demand:** Compared to a simple battery, E-cars will drain the battery as they drive around. So for E-cars, electrical storages you have to define the driving demand as a time series.
- **Availability for charging/discharging:** An electrical car will only be available for charging/discharging when it is connected to the grid. In energyPRO this can be simulated in three different ways:
 - *The simple method:* When the driving demand is zero the E-cars are available for charging/discharging.
 - *A more sophisticated method:* The peak demand (seen during the month) is equal to zero charging/discharging. Zero demand is equal to full charging/discharging. Any value as percentage of the demand in between peak and zero sets the reciprocal value in percentage of the charging/discharging.
 - *A third method:* A user defined time series. 0 is equal to zero charging/discharging. The highest number is equal to full charging/discharging.

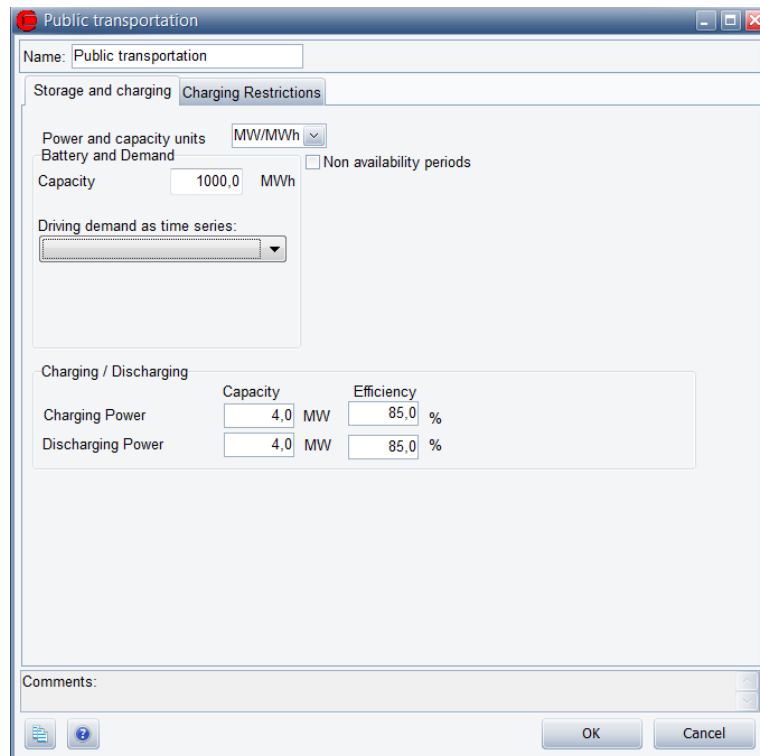

Figure 2.83: The edit window for E-Cars

2.10.4 Cold Storage

Cold Storages in energyPRO are modelled using the same principles as described for Thermal Storage. Cold Storages differ by storing cooling and hereby operation with lower temperatures.

As with a thermal store, you must select which of the production units that have access to the cold storage. This selection is done in the “Operation Strategy” editing window.

A cold storage will also often have a loss over time that depends on the amount of cooling in the storage. This loss can also be modelled in energyPRO.

2.11 Electricity Markets – Wholesale markets

Electricity markets are added either by right-clicking the folder “Electricity market” and choosing “Add new electricity market” or by right-clicking in the Graphical User Mode’s editing window, selecting “Add” and choose “Electricity Market”.

Note that unless the MARKETS module is activated, ONLY one “Electricity Market” may be added to a model. If the MARKETS module is activated any number of “Electricity Markets” may be added. See section 2.11.3 for more on several “Electricity Markets”.

When adding the first (and possibly only) “Electricity Market”, it is possible to choose between two market types.

- Fixed Tariffs
- Spot Market

It is often preferable that energy units produce or consume in certain hours. The reason can e.g. be that the prices paid for electricity may vary significantly within day and night and between weekdays and weekends. In such cases, you need to define an “Electricity Market” and have to choose either “Fixed Tariffs” or “Spot Market”.

Fixed tariffs are tariffs such as the Danish triple tariff or a UK “Day and Night” tariff. “Spot Market” is used when optimization is based on fluctuating electricity spot market prices.

The addition (auto) or (User def.) indicates whether “Operation strategy” is selected to be calculated automatically (Minimizing net heat production costs) or it is user defined.

The layout and functionality of the rest of an Electricity Market window depends on the actual Market Type and choice of “Operation Strategy”.

“Electricity Markets” are fundamental for the optimization calculations done by energyPRO

In an “Electricity Market”, the hours in the planning period are placed into groups with different priorities. In a cogeneration example the hours with the best electricity prices normally will group those hours as top priority, lower prices will get a lower priority and so on. The definition of an “Electricity Market” is fundamental for the optimization calculations done by energyPRO.

“Electricity Market” is closely related to the folder “Operation Strategy”

The “Electricity Market” folder is closely related to the folder “Operation Strategy”, in which the defined “Electricity Markets” is used for setting up an operation strategy for all the production units defined in the project.

Saving and loading

If you choose to import an earlier saved setup of an “Electricity market” you can use this in your calculation or use it as a starting point, when you are editing data. Right click on the folder “Electricity market” and choose “Load electricity market”. The imported data are shown in the window and can now be edited.

If you want to save data, you right click the electricity market you want to save and select save, and specify an expressive name of the file.

2.11.1 Fixed Tariffs

If a fixed tariffs market is chosen you need to define “tariff element names” i.e., names of your tariff levels, and you need to define the priority periods connected to the tariff element names.

Tariff element name

The year will often be divided into several periods, maybe hundreds or even more.

However, they are normally grouped into very few groups, e.g. Peak load periods, High load periods and Low load periods or Day tariff and Night tariff, as seen on Figure 2.84. These groups are named “Tariff element names” and are added in the upper right table.

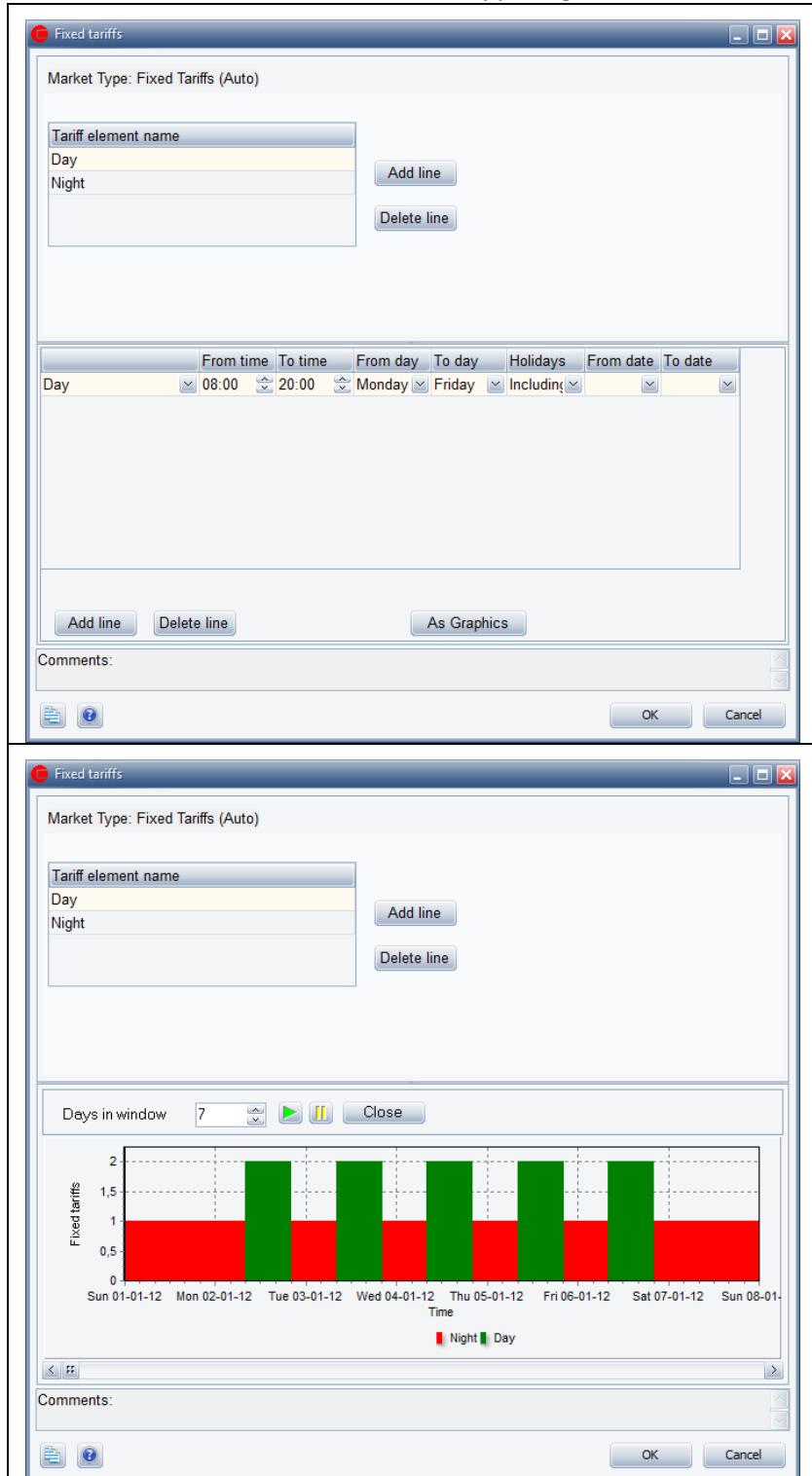

Figure 2.84: Periods of priority –Day-Night tariff example.

In the simple example shown in Figure 2.84, the “Day tariff” is limited to the period from 07:00 to 21:00, Monday to Friday, including holidays. ALL other hours are then automatically defined as “Night tariff”.

In the lower table you define when the already specified “Tariff element names” are located within the year. A period is specified by one or more lines. It is allowed to make overlaps in the description, because the period, which is first in the Tariff element name-list (e.g. Day tariff) are selected first and hereby reserving the specified time span. The next periods on the list have only access to the time spans that are not already reserved by “Tariff element names” with higher priority.

Note: You cannot define periods for the last name, in this example Night tariff. The residual periods that are not defined in the table are automatically allocated to the last “Tariff element name” in the example “Night Tariff”.

If there are no dates specified for “From Date” and “To Date” the period are valid for the whole year.

A whole day is specified as from 00:00 to 00:00.

The screenshot shows a window titled "Fixed Tariffs" with a "Market Type: Fixed Tariffs (Auto)" label. It features a list of "Tariff element name" items: Winter hight, Winter med, Winter low, and Summer. Below this list are "Add line" and "Delete line" buttons. A table below the list details the time periods and dates for each element:

Tariff element name	From time	To time	From day	To day	Holidays	From date	To date
Winter hight	16:00	19:00	mandag	fredag	Including	01-12-21	31-01-22
Winter med	16:00	19:00	mandag	fredag	Including	01-11-21	28-02-22
Winter low	08:00	20:00	mandag	fredag	Including	01-11-21	31-03-22
Summer	08:00	20:00	mandag	fredag	Including	01-04-21	31-10-21
Rest	07:00	00:00	mandag	søndag	Including		

At the bottom of the window, there are "Add line", "Delete line", and "As Graphics" buttons, a "Comments:" field, and "OK" and "Cancel" buttons.

Figure 2.85: Electricity markets. Fixed tariffs, detailed example.

2.11.2 Spot Market

The year will often be divided into several periods, for instance one value for each hour in the year. In the energyPRO optimization, those values have to be divided into a few groups each covering an interval of values.

Depending on whether “User Defined” or “Minimizing Net Heat Production Cost” (auto calculation operation of strategy) is selected in the “Operation Strategy” this is done different and the part of editing window right to the “Market Type” is consequently different, see figure below.

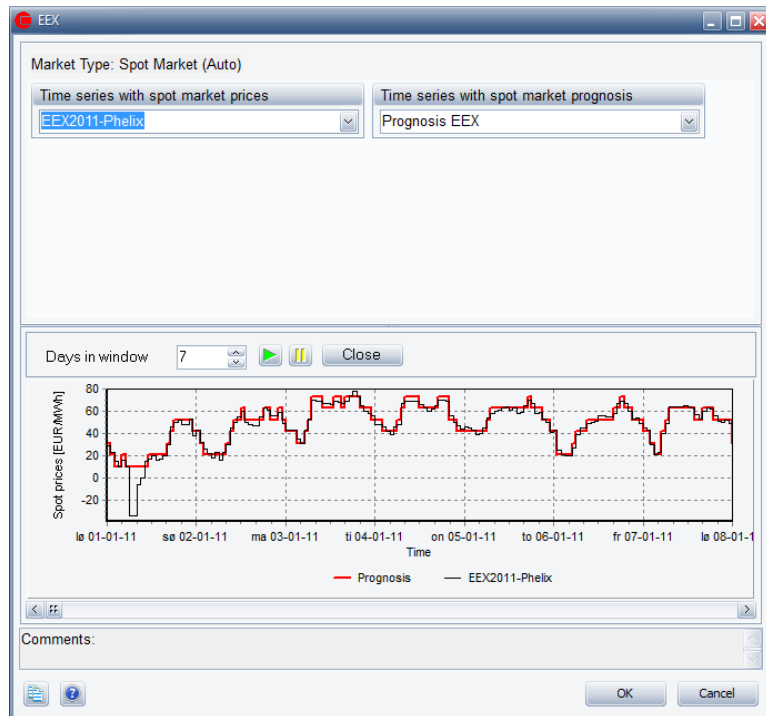

Figure 2.86: Defining “Spot market”.

Common for both the user defined and the auto calculation approach is that they must be based on a selected time series containing spot prices. Note that the time series must first be established as an element in the External conditions folder.

In the example below the time series has got the name “EEX2011-Phelix”, indicating that the time series is holding a set of electrical spot prices.

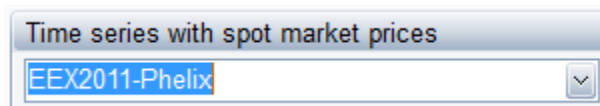

Figure 2.87: Adding name of spot price time series or time series function

Normally you have to create those time series on your own. Delivered with energyPRO there are few examples of time series containing historic electricity spot prices.

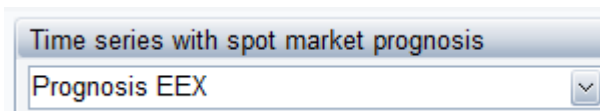

Figure 2.88: Adding prognosis name of time series or time series function

2.11.3 More than one “Electricity Market” in a model (MARKETS)

If you have an activated license to the energyPRO module MARKETS you will be able to have more markets in the same model.

The number of markets is unlimited and the different types of markets can be combined. This is for instance relevant when one CHP engine is selling electricity into the spot market, while another CHP unit is selling electricity to a flat rate tariff. You can have a spot market for your electricity production on CHP and a flat rate market for your electricity consumption. Or, you can have a spot market for one site and a fixed tariff market for the other site (requires REGION).

2.12 Operation Strategy

Intelligent operation strategies are core elements in creating cost-effective energy systems. The layout of the “Operation Strategy” editing window is closely connected to the “Electricity markets”.

You have the option to choose between automatic calculated operation strategy (Minimizing Net Production Cost (NPC)) and user defined (User Defined Operation Strategy).

The figure below shows two examples of operation strategy editing windows for a project with no cooling demand.

The upper example is a project with a user defined operation strategy optimized on a flat rate electricity market, while the lower shows a project with an automatic calculated operation strategy optimized against a spot market.

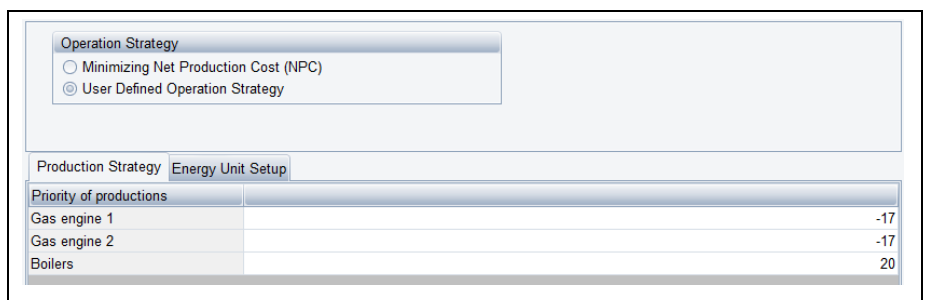

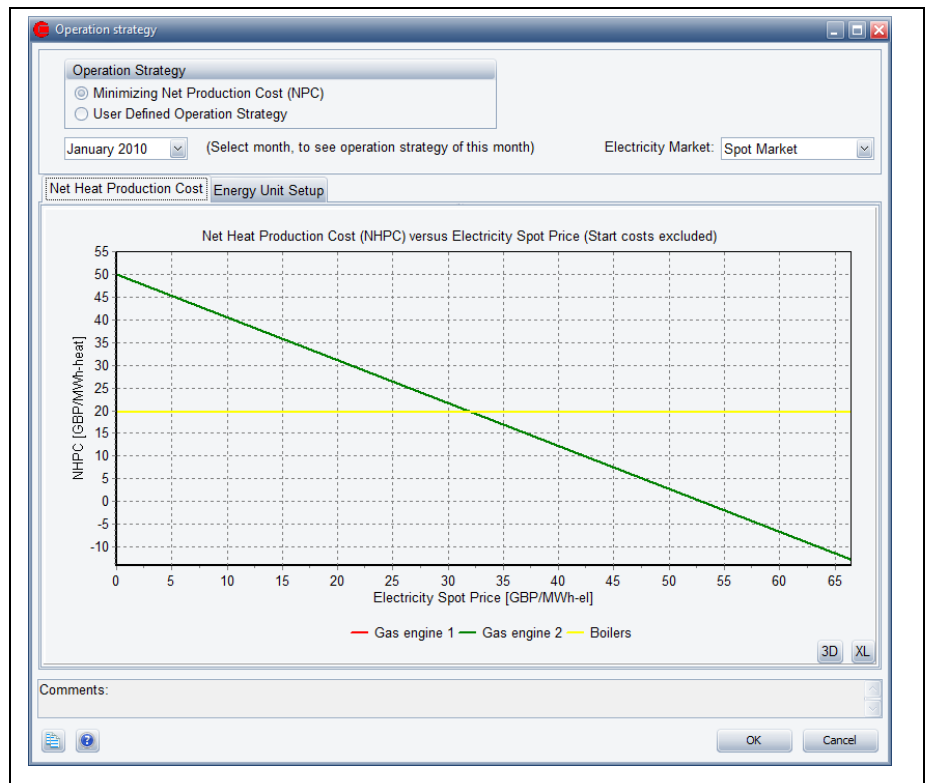

Figure 2.89: Operation Strategy window – Upper simple user defined example – lower auto calculated operation strategy example

energyPRO calculates the optimisation period (month or year) several times. First, it calculates the optimisation period with only the energy units with top priority (e.g. the lowest number) in operation in the considered time interval. Hereafter it calculates the optimization period adding the energy unit with next highest priority in operation, etc. This iterative technique is using the priority set-up in the Operation Strategy.

The two examples in Figure 2.89 are without a cooling demand or fuel producing units enabled. If a cooling demand is added together with cooling producing units, e.g. Electric chillers, a new tab for the “Net Cooling Production Cost” will be added to the operation strategy. This tab will be similar to the tab “Net Heat Production Cost”, except that it will show the priority of production of cooling at different electricity prices. Similar if “Fuel producing energy units in project” has been enabled in the “Project Identification” a tab called “Fuel Production strategy” will appear, in which you can define the max allowed priority number of the fuel producing unit, which is the highest priority number in the Production Strategy the units consuming the fuel produced will allow the fuel producing unit to run at.

For the shown auto calculated operation strategy in Figure 2.89, the tab “Energy Unit Setup” looks as shown in Figure 2.90.

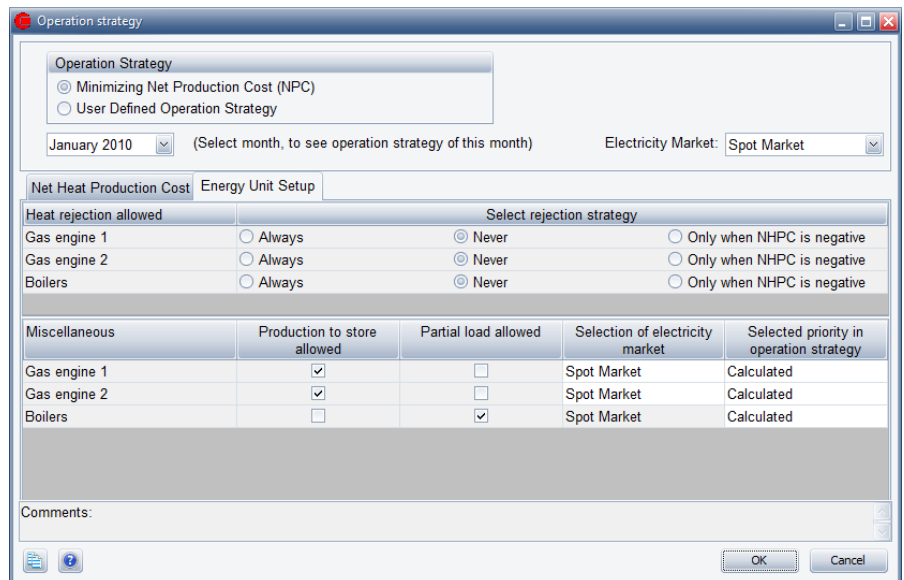

Figure 2.90: “Energy Unit Setup” tab for the lower example in Figure 2.89

Heat Rejection allowed: This section is visible only if a heat rejection unit is added. You check the production unit(s) that has access to the heat rejection unit.

Miscellaneous: The Operation Strategy window changes its appearance dependent on the following factors:

- Does the project include electricity demand
- Does the project include thermal storage
- Does the project contain transmissions
- Is the operation strategy calculated automatic

You have to check allowances and restrictions towards these options. E.g. is the production from an energy conversion unit allowed to be transmitted to another site? Which energy conversion units are allowed to produce to thermal store? Which energy conversion units are allowed to run on partial load etc.?

2.12.1 Operation strategy

You have to decide how your “Operation Strategy” should be set up. There are two options “Minimizing Net Production Cost”, which automatically will fill in numbers in the Priority table, and “User Defined Operation Strategy”. There are three situations depending of selected wholesale market

- No wholesale electricity market present in project
- Whole sale market is a fixed tariff market
- Whole sale market is a spot market

Operation strategy if no electricity market is defined

The figure below show an operation strategy in a project, where there is no electricity market defined. In the user defined (upper) part you simply state the priorities for the production units. In this example the solar collector get the top priority, here 1 (lowest number) and the boiler priority 2 covering the residual demand. In the automatic calculation (lower) the priorities are calculated automatically. In the example the operation cost of the Solar collector is calculated to 0 €/MWH-heat and the production cost on the boiler is calculated to 29€/MWH-heat .

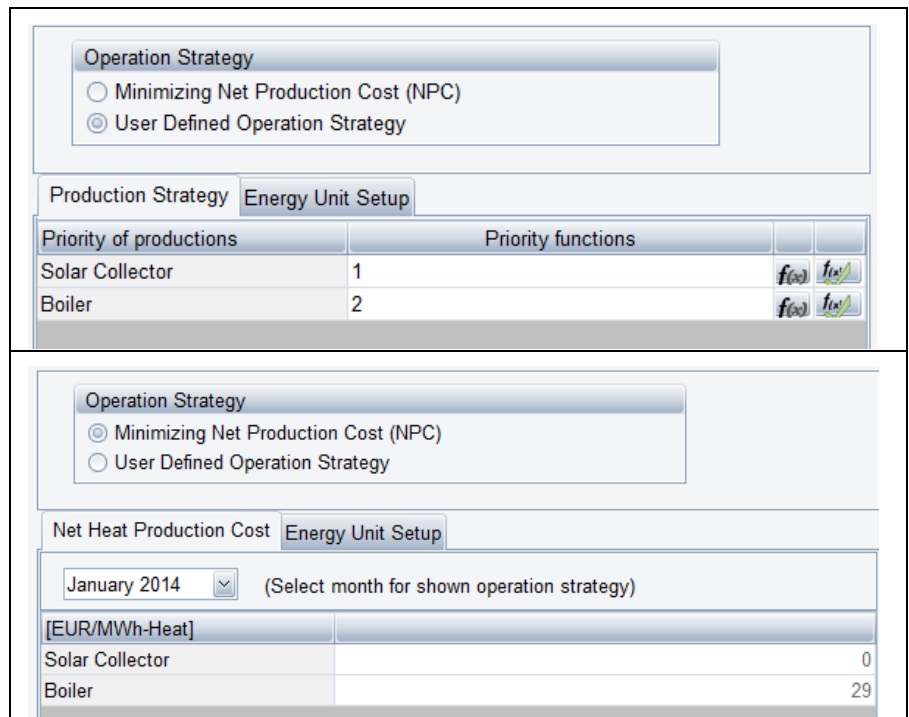

Figure 2.91: Operation strategy table, no electricity markets. Upper: "User Defined Operation Strategy". Lower: "Minimizing Net Heat Production Cost".

Operation strategy if the electricity market is a fixed tariff market

Figure 2.92 shows an example of an operation strategy, where the wholesale market is a fixed tariff market. If "Minimizing Net Production Cost" is selected then the Operation Strategy will be calculated based on the "Operation Expenditures" and the "Revenues" that you have defined in your "Economy". Hence, it is of crucial importance that these are made accurate. These priority numbers cannot be edited while "Minimizing Net Heat Production Cost" is selected. Choosing "User Defined Operation Strategy" hereafter will keep the calculated values and make the table editable.

The functionality of "Minimizing Heat Production Cost" is described in the next section.

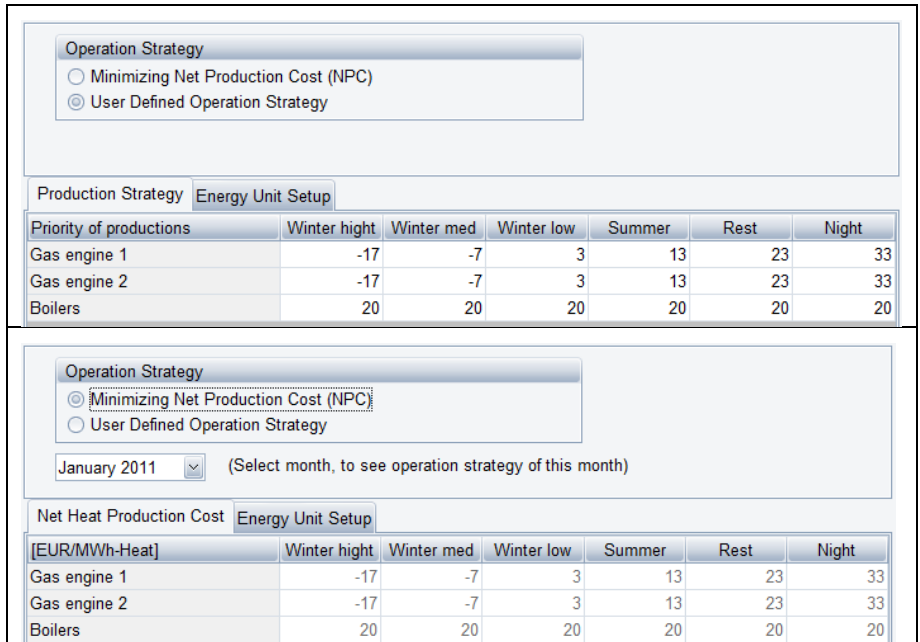
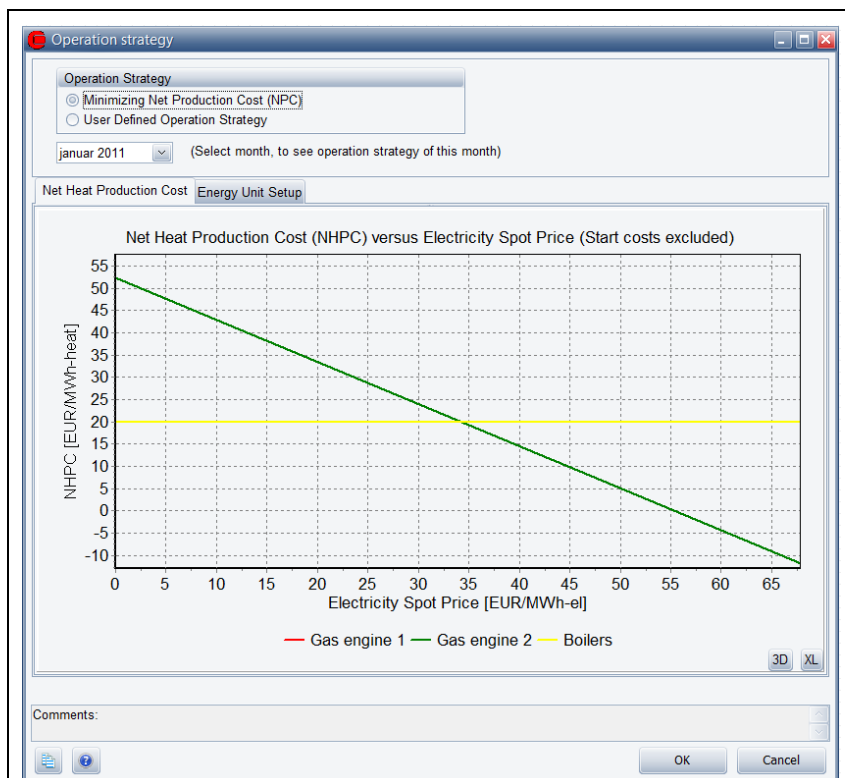

Figure 2.92: Operation strategy table, fixed tariffs. Upper: "User Defined Operation Strategy". Lower: "Minimizing Net Heat Production Cost".

Operation strategy if Electricity market is "Spot market"

If the "Electricity market" is "Spot market", the Operation strategy window is different depending on whether "Minimizing Net Production Cost" or "User Defined Operation Strategy" is selected, see Figure 2.93.



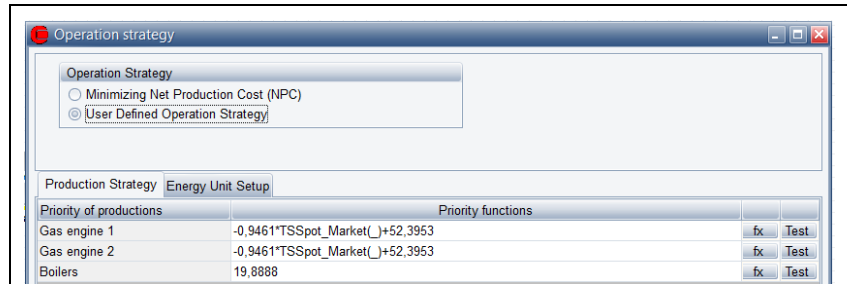

Figure 2.93: Operation strategy table, Spot Market. Upper: “Minimizing Net Heat Production Cost”. Lower: “User Defined Operation Strategy”.

If “Minimizing Net Production Cost” is selected the operation strategy table is substituted by a graphic representation of the Net Heat Production Cost for energy production units as function of the electricity spot prices.

If “User Defined Operation Strategy” is selected the priority of productions tabsheet has a priority functions input field instead of the period divided input seen in fixed tariffs.

When swapping from “Minimizing Net Production Cost” to “User Defined Operation Strategy”, the priority functions will initially be generated automatically based upon the values behind the “Minimizing Net Heat Production Cost” graphics. The functions in Figure 2.93 (lower figure) are linear functions identical with the lines in Figure 2.93 (upper figure).

Functions available for creating priority functions can be seen by pressing the Fx-button. Available functions are symbols from time series and time series functions and some mathematical functions.

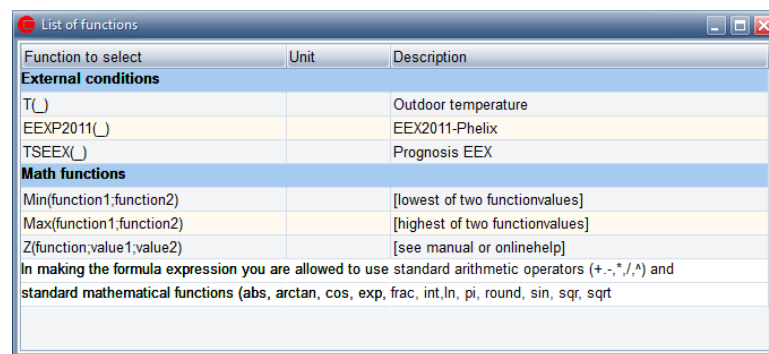

Figure 2.94: Example of list of functions available for setting priorities in user defined strategy

Pressing the test –button checks that the specified function expression is valid.

Automatic calculation of operation strategy – How is it done?

The basic idea behind the automatic operation strategy calculations in energyPRO is that the “Net Heat Production Costs”, and “Net Cooling Production Costs” if a cooling demand is added, are calculated for each production unit in all time intervals. For instance, if there is six tariff periods in a fixed tariff calculation, six prices for the “Net Heat Production Costs” and “Net Cooling Production Costs” are calculated for

each of the production units, forming a priority table. When calculating the energy conversion, energyPRO first places as much production as possible on the production unit/tariff period combination represented by the smallest value in the priority table. Hereafter the production unit/tariff period represented by the second smallest net heat production cost will get as much production as possible, etc. This is done until all demands are met or the production opportunities are exhausted. Also see 3.1 Method of energy calculation in energyPRO.

The calculation of the operation strategy is entirely based upon the “Revenues” and the “Operation expenditures” set up by the user to describe the Operation income. Therefore it is of crucial importance that these payments are set up properly, prior to the energy conversion calculation. The energy and economy calculation are tied together and will affect each other. The operation strategy is calculated for each month in the planning period.

The methodology for calculating the operation strategy is an incremental approach where each of the heat-producing units is calculated as stand-alone units producing one MWh-heat, and each of the cooling producing units as producing one MWh-cooling. In this calculation, all the payments in “Revenues” and “Operation expenditures” are evaluated and calculated. The calculation is repeated for each production unit in each electricity tariff period.

This is the case for production units with heat production. In Figure 2.95 is shown the heat-producing units in energyPRO. This is CHP, Boiler, Electrical heat pump and User defined. Note that a “User defined” production unit needs a heat production typed into the power curve.

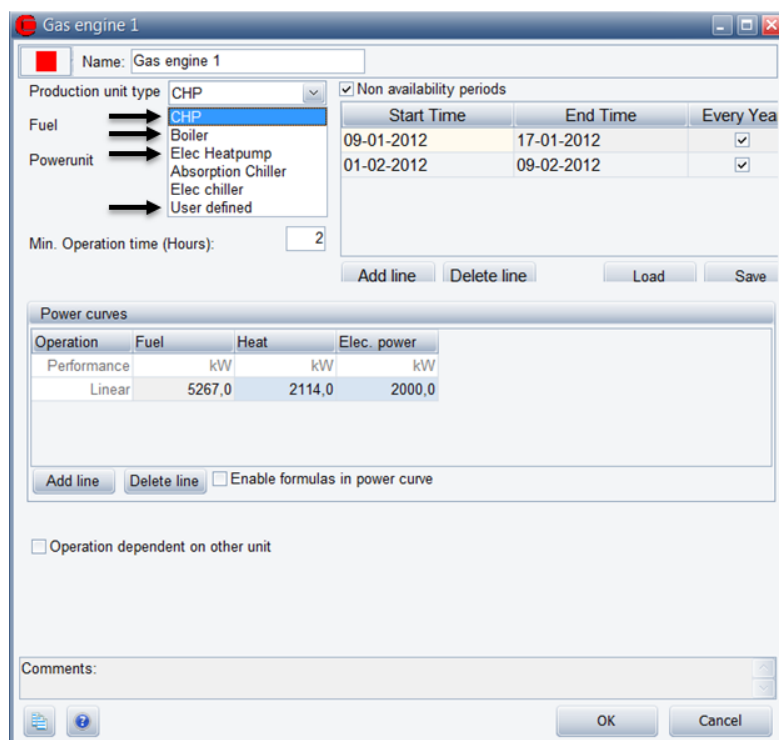

Figure 2.95: Net Heat production costs are only calculated for Heat producing Production units.

Photovoltaic and Wind farms are always set to a priority higher than all heat-producing units. Hereafter the heat producing units are calculated followed by the cooling producing units. Of the cooling producing units the absorption chillers are calculated first and finally the electric chillers.

The priority of the absorption chiller is defined as Max allowed heat production cost. Meaning, that if the Absorption chiller is to produce cheaper than the electric chiller in the same time interval, then the heat producing unit has to have a heat production cost lower than Max allowed heat production cost.

If a payment is the same for all productions units in all tariff periods the payment is ignored. By other words fixed payments not related to the operation of production units are eliminated.

In annex D is shown how the formulas that may occur when describing the payments, are interpreted when being used to calculate the operation strategy.

Each month new operation strategies are calculated. By selecting a month in the project period, the corresponding operation strategy is calculated and shown in the table as shown in Figure 2.96.

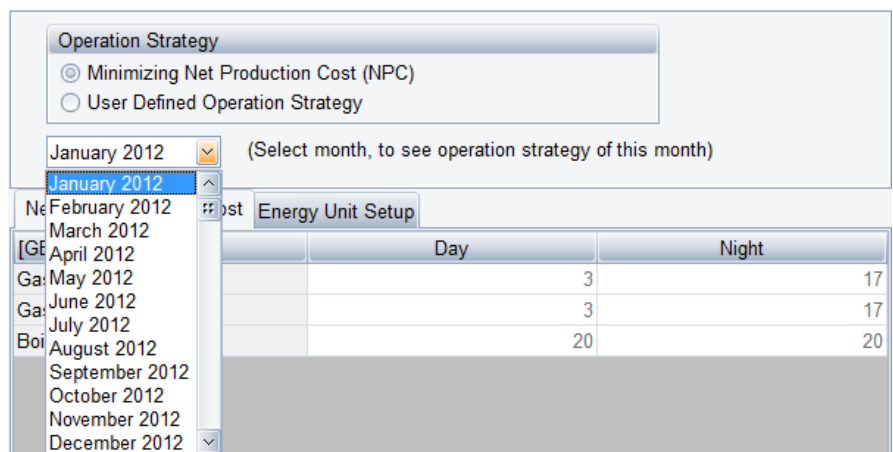

Figure 2.96: The operation strategy for an arbitrary month of the planning period can be selected

Limitations in use of the automatic calculation of Operation Strategy

If either the process heat production option or the fuel producing option is enabled, as indicated on Figure 2.97, then only the user defined operation strategy is available.

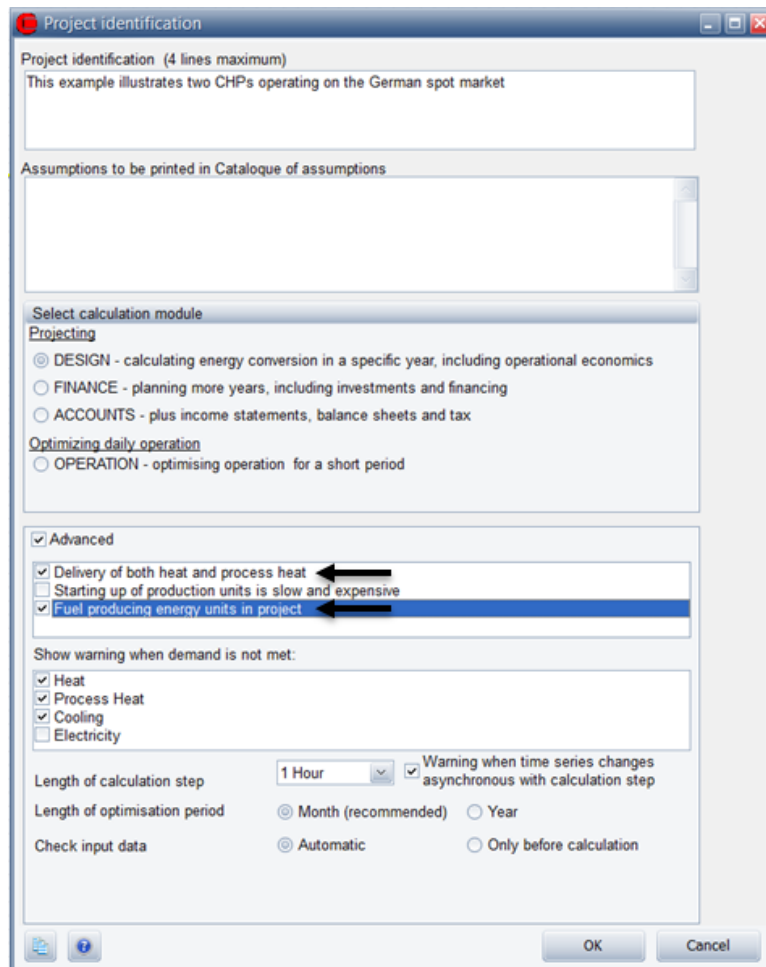

Figure 2.97: Automatic calculation of the operation strategy are not possible if either the process production option or the fuel producing units option are enabled.

2.12.2 Heat rejection table

The heat rejection table is only visible if a heat rejection unit is defined (an Energy Conversion Unit). The heat rejection table is located in the Energy Unit Setup tab.

Heat rejection allowed	Select rejection strategy		
Gas engine 1	<input type="radio"/> Always	<input type="radio"/> Never	<input checked="" type="radio"/> Only when NHPC is negative
Gas engine 2	<input type="radio"/> Always	<input type="radio"/> Never	<input checked="" type="radio"/> Only when NHPC is negative
Boilers	<input type="radio"/> Always	<input checked="" type="radio"/> Never	<input type="radio"/> Only when NHPC is negative

Figure 2.98 Heat rejection table layout

In the heat rejection table there are three options. These are that the energy production unit 1) always has access to blow off, 2) never has access to blow off and 3) the units have access to blow off only if the units are able to produce heat at negative heat production costs. An example hereof could be hours with high prices at the spot market.

2.12.3 Miscellaneous table

There are five standard columns in the miscellaneous table, those are:

1. Production to thermal store allowed (only visible if a thermal store is specified)

2. Transmit to other sites allowed (only visible if there is more than one site in a project)
3. Partial load allowed
4. Selection of electricity market
5. Selected priority in operation strategy (only visible if the operation strategy is auto calculated)

Miscellaneous	Production to store allowed	Transmit to other sites allowed	Partial load allowed	Selection of electricity market
Gas engine 1	<input checked="" type="checkbox"/>	<input checked="" type="checkbox"/>	<input type="checkbox"/>	Fixed tariffs
Gas engine 2	<input checked="" type="checkbox"/>	<input checked="" type="checkbox"/>	<input type="checkbox"/>	Fixed tariffs
Boilers	<input type="checkbox"/>	<input checked="" type="checkbox"/>	<input checked="" type="checkbox"/>	

Miscellaneous	Production to store allowed	Transmit to other sites allowed	Partial load allowed	Selection of electricity market	Selected priority in operation strategy
Gas engine 1	<input checked="" type="checkbox"/>	<input checked="" type="checkbox"/>	<input type="checkbox"/>	Fixed tariffs	Calculated
Gas engine 2	<input checked="" type="checkbox"/>	<input checked="" type="checkbox"/>	<input type="checkbox"/>	Fixed tariffs	Calculated
Boilers	<input type="checkbox"/>	<input checked="" type="checkbox"/>	<input checked="" type="checkbox"/>		Calculated

Figure 2.99: Miscellaneous table layout. Upper is when the operation strategy is User defined, and the lower is when it is automatic operation strategy

ad 1) State whether the production units have access to the storages.

ad 2) State whether the production units are allowed to transmit energy to other sites.

ad 3) State whether the production units are allowed to run on partial load.

ad 4) If the operation strategy is auto calculated this column give the opportunity to overrule the predefined standard settings, which are

- Boiler: calculated
- CHP: calculated
- Elec. Heat pump: calculated
- User defined unit: calculated
- Absorption cooler: calculated
- Electric cooler: calculated
- Wind farm: High
- Solar collector: High
- Photovoltaic: High

If an electricity market is added to the model a new column is opened in the miscellaneous table in the operation strategy. This table contain a drop-down box in which it is possible to select between the different electricity markets (It is only possible to have more than one electricity market if MARKETS module is activated). This is done for each production unit that are producing and/or consuming electricity.

Miscellaneous	Production to store allowed	Partial load allowed	Selection of electricity market	Selected priority in operation strategy
Gas engine 1	<input checked="" type="checkbox"/>	<input type="checkbox"/>	Spot Market	Calculated
Gas engine 2	<input checked="" type="checkbox"/>	<input type="checkbox"/>	Spot Market	Calculated
Boilers	<input type="checkbox"/>	<input checked="" type="checkbox"/>	Spot Market Flat Rate	Calculated

Figure 2.100 Select the electricity market each of the energy production units are traded at. Here the electricity markets are named "Spot Market" and "Flat Rate".

If electricity demand(s) are defined in the project a market has to be selected as for the production units. Note that all demands are pooled in this table and subsequently attached to the same market.

Miscellaneous	Production to store allowed	Partial load allowed	Selection of electricity market	Selected priority in operation strategy
Gas engine 1	<input checked="" type="checkbox"/>	<input type="checkbox"/>	Spot Market	Calculated
Gas engine 2	<input checked="" type="checkbox"/>	<input type="checkbox"/>	Flat Rate	Calculated
Boilers	<input type="checkbox"/>	<input checked="" type="checkbox"/>		Calculated
Electricity demand			Flat Rate	

Figure 2.101 Select the electricity market for electricity demands(s).

2.12.4 The Island Operation Strategy

If you have created an electricity demand in your project, you will in the Operation strategy-window be able to choose "Island operation".

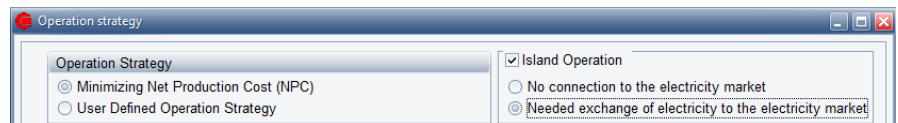

Figure 2.102: The island operation mode is visible in the upper right corner of the Operation Strategy when you have electricity demands in your project

When "Island operation" is chosen, the operation will not be focused on optimizing the electricity productions at the chosen electricity markets, but will be focused on covering the electricity demand (at "the island"). The "island" is not necessarily a real island, but could be a local area, that has focus on covering its own electricity demand.

In such a project there will often be a heat and/or cooling demand to be covered (at "the island"). It has equal priority to cover these demands.

The produced heat to cover the heat demand can be stored for a longer period in a thermal store.

The produced electricity to cover the electricity demand can be stored for a longer period in e.g. a hydro pumping storage.

The produced cooling to cover the cooling demand can be stored for a longer period in a cold store.

In the Operation strategy window you may choose User Defined Operation Strategy to determine in which order the production units will be put in operation.

You may also choose to accept the suggested operation strategy determined by the net heat production costs. In this version of energyPRO you will then have to decide yourself the priority of the production units that do not produce heat but produce electricity. For these units you can choose between High priority and Low priority, compared to the production units producing heat.

You are NOT able to decide the priority of a hydro pumping storage. Excess electricity (compared to the electricity demand) will be stored in the hydro pumping storage (if possible).

In hours where the production units are not able to cover the electricity demand, the hydro pumping storage will try to deliver the rest (perhaps limited by the capacity of the hydro pumping storage).

When "Island operation" is chosen, you can further choose between:

- NO connection to the electricity market
- Needed exchange with the electricity market

If "Needed exchange with the electricity market" is chosen, production units with excess capacity will be allowed to export (Exported electricity) and not covered electricity demand will be covered through import (Imported electricity).

Only production units with a negative number in the "Priority of production" section of the "Operation strategy" are allowed to export.

2.13 Environment

This folder is used to define emissions in energyPRO, such as CO₂, NO_x and CO₂.

The folder structure under environment is also used to structure the report "Environment, summary".

Emission types can be established by right clicking the mouse standing on the environment root folder under the option "add new emission".

To each emission type physical units of amounts has to be chosen. This is done in the editing windows, corresponding with the actual emission folders. For each emission type, there are two options for units. Those are:

- Mass
- User defined

The first one is shown in the figure below. There are five mass units that are allowed. Those are "gram", "kg", "ton", "1000 ton" and "mill. ton". The "Used in input" unit is the one used when describing specific emission values in the editing window". The "Used in reports" units is the one used in the "Environment"-report. If the emission type is "user defined", it is possible to type in a text string instead. This will be used instead of the five predefined mass units, and will appear both in input data and in the reports.

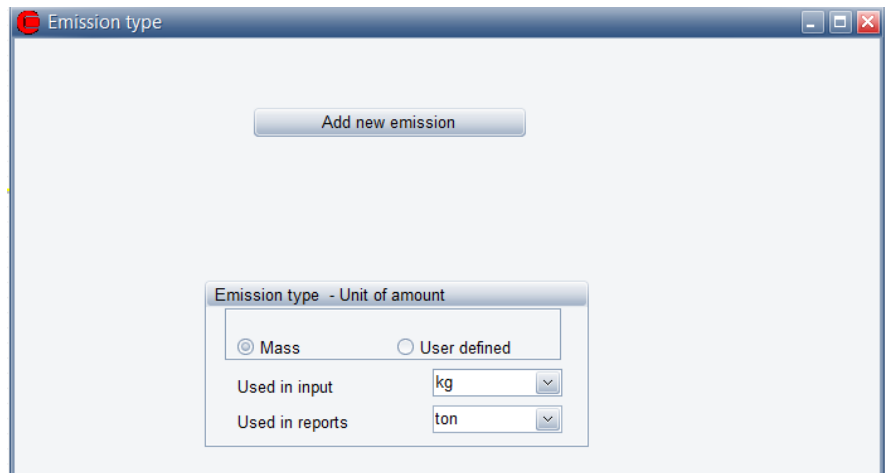

Figure 2.103: Emission type values. Default values for CO₂.

For each emission type, an unlimited number of emissions can be added. A new emission is added by pointing on the actual emission type folder, right clicking the mouse and choosing add new emission or simple pressing the “Add new emission” on the emission type window, see the figure above.

This will open an editing window to specify the emission. This window is similar to the window used in the economy to describe “Revenues” and “Operation expenditures”. Please refer to section 2.15, and to chapter 4 “Functions in energyPRO”, where you find a detailed description of the functions to be used in energyPRO.

Normally it is simpler to model the emissions in the “Revenues” and “Operation expenditures”. Most cases are covered within two different situations, as emissions are normally directly related to either the amount of used fuel or to the process of energy conversion.

The first case is the situation CO₂. In the figure below the case is described by choosing “Imported fuel”, the fuel “natural gas” and a specific amount of 2,27 Nm³.

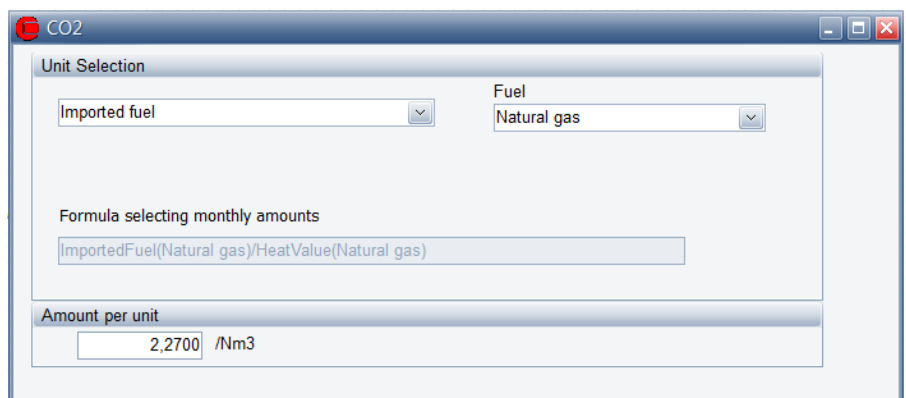

Figure 2.104: Emission example fuel dependent

Note that the “kg” part of the unit comes from emission type unit and the “Nm³” part comes from the unit in which the actual fuel is typed.

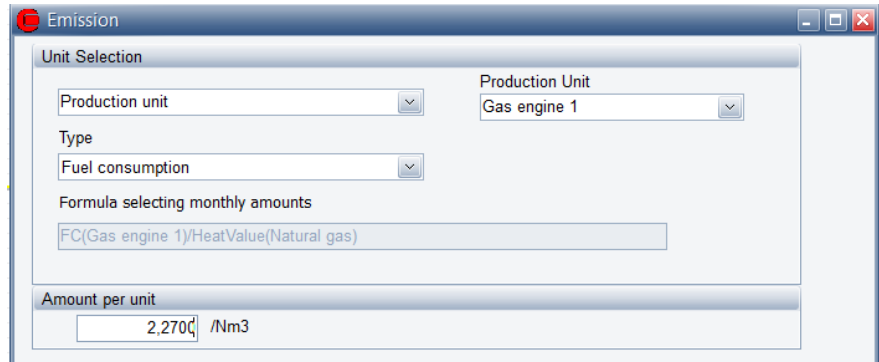

Figure 2.105: Emission example technology dependent

In the second case where emissions is technology dependent, the situation can normally be described by choosing “Production unit”, “Fuel consumption” and the desired production unit in the production unit combo-box, in this example “Gas engine 1”.

If the project is in either FINANCE or ACCOUNTS it is also possible to attach an index to the amount of emission per unit. This is useable for simulating e.g. changing CO₂ emission of imported electricity over the years.



Figure 2.106: Emission example technology dependent

2.14 Economic input data

2.14.1 Facilities in the economic section

The facilities in the economy module depends on which energyPRO module that are presently selected in the “Project Identification”.

Basic elements for all modules are the folders “Revenues” and “Operational expenditures”. “Investments” and “Financing” are available in Finance and Accounts only while “Taxation” is an option only in “Accounts”, see Figure 2.107.

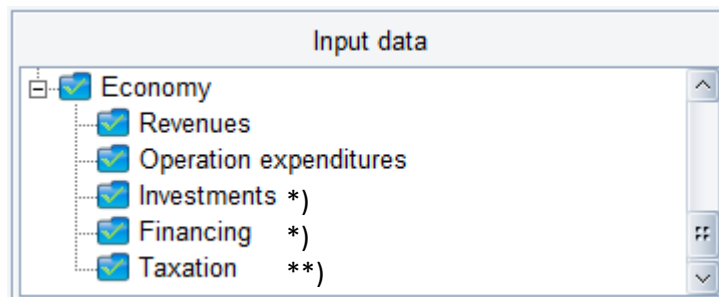

*) Finance and Accounts **) Accounts only

Figure 2.107: Economy input data

2.14.2 Economy – Main folder:

The content of the editing window accompanying the economy main folder is module dependent.

- DESIGN: "Currency".
- FINANCE: "Currency", "Inflation index" and "Nominal discount rate" and investment key figures option.
- ACCOUNT: "Currency", "Inflation index" and "Nominal discount rate" and investment key figures+ Define annual key figures.

The input typed in this window will be used when creating the report "Financial Key figures".

The "Currency", "Inflation index" and "Nominal discount rate" input windows are shown in Figure 2.108. ("Inflation index" and "Nominal discount rate" are only available in FINANCE and ACCOUNTS).

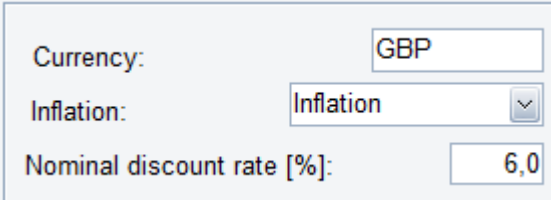

The screenshot shows a light blue dialog box with three input fields. The first field is labeled 'Currency:' and contains the text 'GBP'. The second field is labeled 'Inflation:' and contains a dropdown menu with 'Inflation' selected. The third field is labeled 'Nominal discount rate [%]:' and contains the number '6,0'.

Figure 2.108: Economy – Main folder

Currency: The name/symbol of the currency (Used for presentation only).

Inflation: Select which of your created indexes that describes the inflation.

Nominal discount rate: The nominal discount rate is used for calculating the "Present Value" of the investment. See the report Financial Key Figures

Indexes

Indexes used for economy calculations should be defined in the External Conditions of the Input Data window, and then referenced in the Economy – Main folder window.

For more details, please see the description in the "General Input Data" section, External conditions - Indexes

Investment key figures

If the FINANCE or ACCOUNTS is selected, there are two general project evaluation options available:

- Present value
- Internal Rate of Return

Note that the present value is calculated using the "Nominal discount rate".



Figure 2.109: Key figures. Present value selected as investment key figure.

The selection is made in the Economy editing window, see Figure 2.109.

IRR (Internal rate of return) in energyPRO

When you choose to include Internal rate of return in your calculation you get the following warning.

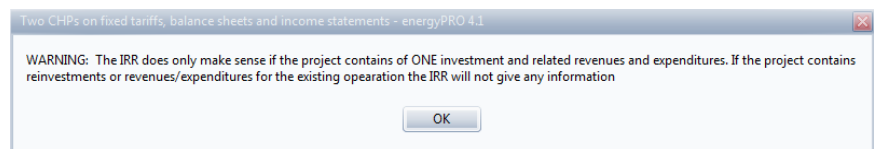

Figure 2.110: Warning about Internal rate of return.

The IRR calculation in energyPRO is either monthly or annual based. This means that all payments within a month are summed up to one value each month or alternatively all payments within a year are summed up to one value each year. The IRR is then calculated using this time series defined by these monthly or annual sums.

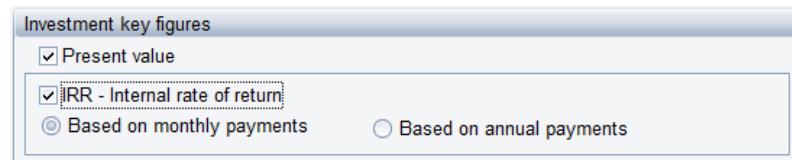

Figure 2.111: In energyPRO IRR is either monthly or annually based.

If the created time series contain more negative values than the initial investment, there might be more solutions causing the IRR to be ambiguous. Another problem might be that the iteration routine finding the IRR will not converge. In that case a message in the “Financial key figures”-report will tell that the IRR is “Not found”.

There will be cases, where the time series start with positive values (income) before the investments will cause the iteration routine, finding the IRR will not converge.

The monthly based IRR might show the most correct IRR while the annual based IRR in some cases will be more robust. In the annual case, some months with negative values might be eliminated when summed up annually.

Please remember, that you define all the payments you want to include in the calculation. Therefore it is extremely important, if you want to use IRR for comparing investments, that you are careful about not including irrelevant payments.

More information about IRR in energyPRO is found in section 3.2.3

Define key figures

You can choose to include predefined key numbers in the report “Financial Key numbers”.

Name of key figures	[Unit]	Formula for key figures	Shown as		
Quality Index	MB	QI(200;125)	Number	fx	Test
Production cost per MW	GBP/MW	Result/(HD(Total sale of heat)+HI	Number	fx	Test

Figure 2.112: Key Figures. Example with “Define annual key figure” defined.

If you check the facility “Define annual key figures” you can type in the wanted key figures by defining their names, formulas and presentation (as percentage or as number).

There is a set of predefined functions available for creating your formulas. These functions are based on the annual amounts calculated in “Income Statements” and “Balance Sheets”. Hereto come a large number of functions based on energy demand and energy conversion, and mathematical standard expressions and functions such as Min, Max etc.

Hereto comes the possibility of defining headers. In that case type in the header text in the column “Name of key figures” and select the “Header”-option in the “Shown as” column.

You can use the following built-in functions. The functions all return annual values.

Financial keyfigures		
Revenues	[<Currency>/Year]	Revenues
OperationExpenditures	[<Currency>/Year]	Operation expenditures
Result	[<Currency>/Year]	Result
Result	[<Currency>/Year]	Result
Depreciations	[<Currency>/Year]	Depreciations (Accounts only)
FinancialExpenditures	[<Currency>/Year]	Financial expenditures (Accounts only)
ExtraordinaryIncome	[<Currency>/Year]	Extraordinary income (Accounts only)
Tax	[<Currency>/Year]	Tax (Accounts only)
FixedAssets	[<Currency>/Year]	Fixed assets (Accounts only)
CashAccount	[<Currency>/Year]	CashAccount (Accounts only)
OtherCurrentAssets	[<Currency>/Year]	Other current assets (Accounts only)
OwnersCapital	[<Currency>/Year]	Owners capital (Accounts only)
TransferredResult	[<Currency>/Year]	Transferred result (Accounts only)
Reserves	[<Currency>/Year]	Reserves (Accounts only)
ShortTermLiabilities	[<Currency>/Year]	ShortTerm liabilities (Accounts only)
LongTermLiabilities	[<Currency>/Year]	LongTerm liabilities (Accounts only)

Table 2.2: Financial functions available for defining annual key figures

System Level(aggregate of all production units and demands)		
ImportedFuel(FUEL)	[MWh/year]	Imported fuel
ExportedElectricity(MARKET;PERIOD)	[MWh/year]	Exported electricity
ImportedElectricity(MARKET;PERIOD)	[MWh/year]	Imported electricity
PeakImportedFuel(FUEL)	[MW/year]	Peak imported fuel
PeakExportedElectricity(MARKET;PERIOD)	[MW/year]	Peak exported electricity
PeakImportedElectricity(MARKET;PERIOD)	[MW/year]	Peak imported electricity
APeakImportedFuel(FUEL)	[MW/year]	Annual peak imported fuel
APeakExportedElectricity(MARKET;PERIOD)	[MW/year]	Annual peak exported electricity
APeakImportedElectricity(MARKET;PERIOD)	[MW/year]	Annual peak imported electricity
Production Unit Level		
HP(PRODUCTIONUNIT)	[MWh/year]	Heat production
EP(PRODUCTIONUNIT;PERIOD)	[MWh/year]	Electricity production
CP(PRODUCTIONUNIT)	[MWh/year]	Cooling production
FP(PRODUCTIONUNIT)	[MWh/year]	Fuel production
FC(PRODUCTIONUNIT)	[MWh/year]	Fuel consumption
EC(PRODUCTIONUNIT;PERIOD)	[MWh/year]	Electricity consumption
HC(PRODUCTIONUNIT)	[MWh/year]	Heat consumption
Turnons(PRODUCTIONUNIT)	[Number of turnons/yea	
HoursOfOperation(PRODUCTIONUNIT)	[Hours of operation/yea	
FullLoadHours(PRODUCTIONUNIT)	[Hours of operation/yea	
Demand functions		
HD(DEMAND)	[MWh/year]	Heat demand
ED(DEMAND;PERIOD)	[MWh/year]	Electricity demand
CD(DEMAND)	[MWh/year]	Cooling demand
PHD(DEMAND)	[MWh/year]	Process heat demand
PeakElectricDemand(DEMAND)	[MW/year]	Peak electricity demand
EnergyUnit conversion (functions converting from energy units to original input data unit)		
HeatValue(FUEL)		
UnitofDemand(DEMAND)		
Math functions		
Min(function1;function2)		[lowest of two functionvalues]
Max(function1;function2)		[highest of two functionvalues]
Z(function;value1;value2)		[see manual or onlinehelp]
In making the formula expression you are allowed to use standard arithmetic operators (+, -, *, /, ^) and standard mathematical functions (abs, arctan, cos, exp, frac, int, ln, pi, round, sin, sqr, sqrt		
Special Pool functions		
SpotPricesXExportedElectricity(MARKET)		Spotprices times exported electricity
SpotPricesXImportedElectricity(MARKET)		Spotprices times imported electricity

Table 2.3: Other functions for defining annual key figures

In chapter 4 “Functions in energyPRO” is found a detailed description of the functions to be used in energyPRO.

2.15 Revenues and Operational Expenditures

Essentially, revenues and operational expenditures consist of picking out results from the energy calculation and multiply these results with unit prices. This is done for all the payments you want specified.

An unlimited number of payments can be established. Each of these payments produces one line in the Economy printouts.

The Payments can be grouped in payment groups. A group of payments is in the Economy printouts shown as a sub balance of the payments in the group.

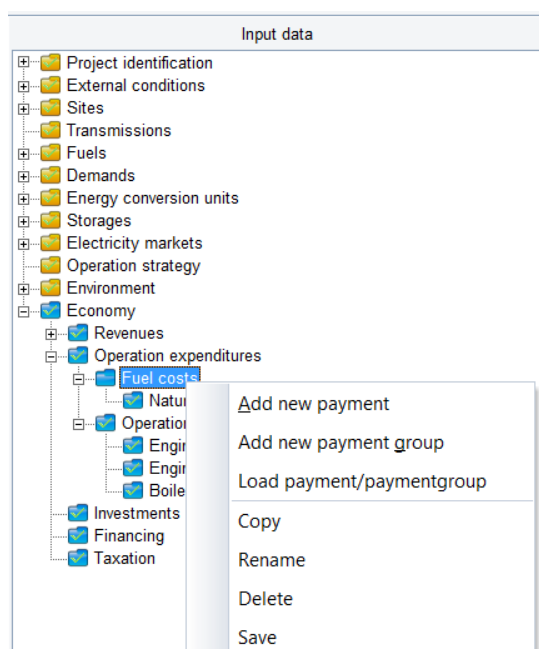

Figure 2.113: Adding payments or payment groups to “Revenues” and “Operation expenditures”.

Add payment group:

If you right click, you can add a payment group

You can collect payments into groups and in this way organize your economy report just as you like. Each group of payments represent a subtotal in the complete economy report.

You can also save the group or the payment and use it in future calculations. If you want to use an earlier saved group of payments, you can choose “Load payment/payment group” in the menu and choose between the saved payments or groups of payments. Remember to check the imported lines of payments for consistency because all of the energy units, fuels and so on from the earlier project not necessary exist with the same names in the present project.

Often a saved payment group is usable as a template, where the single payments have to be edited.

Add payment:

If you right click, you can add a new payment and a default payment window will appear as on Figure 2.114. The Payment window consists of the three main panels; “Unit selection”, “Price per unit” and “Include in operation strategy”. If the FINANCE or ACCOUNTS module is selected the panels “Development of Price” and “Advanced” are added.

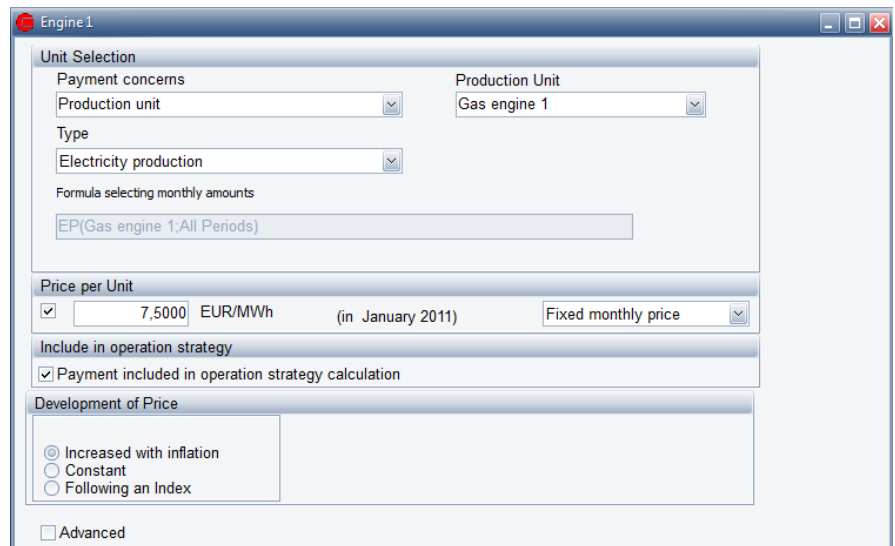

Figure 2.114: Payment Window: Revenues and Operational Expenditures

Unit Selection

Payment concerns:

“Payment concerns” is the key to constructing a payment. Here you have to select one of the following items:

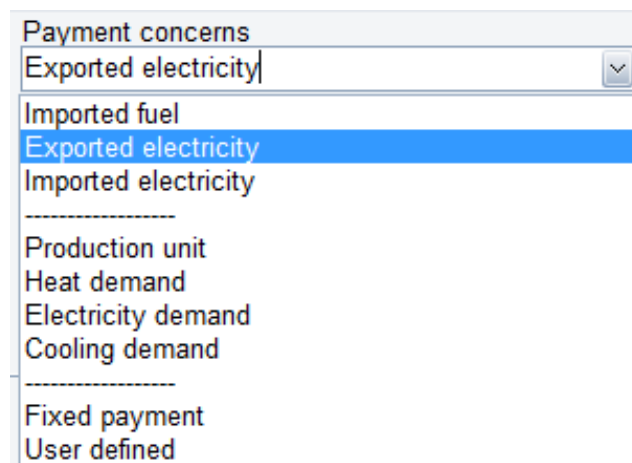

Figure 2.115: The Payment concern combo-box

The selection of an item in “Payment concerns” combo-box decides the layout of the rest of the editing window. E.g. will combo-boxes be visible or not visible depending on selected item in “Payment concerns” combo-box.

The first three items concerns fuels and electricity exchange crossing the system border. The system is defined in section 4.5 “Functions used only in Revenues and Operational Expenditures”

“Exported electricity” and “Imported electricity”, describes the electricity produced minus electricity consumed either by the production plants themselves or by an actual electricity demand.

“Imported fuel” is the fuel imported to the energy units.

The Next Group of items “Production unit” and the various Demands are used when a payments is added to the production of a specific Production unit or to a specific demand.

“Fixed payment” is a possibility to create a payment which is independent of the energy conversion and the operation of the actual energy system. Note that the “price pr. unit” in this case is interpreted as the total annual payment. You consequently have to type in the annual amount in this field.

User defined payment: If you have selected “User defined” in “Payment concerns” you get access to edit the formula field. See also User defined payment selected in “payment concerns”

Formula selecting monthly amounts:

In this field a formula created by the selections in combo-boxes above are shown. The field is grey and inaccessible except when “User defined” is selected in the “Payment concern” combo-box.

Note: If Spot market is selected in “Electricity Market” then choosing “Exported electricity” in “Payment concerns” then energyPRO automatically suggests the formula that returns the value of the sold electricity. If you do not want that then uncheck the “Spot market payment” option.



Figure 2.116: The value of electricity sold to electricity spot market

Price per Unit:

The price per unit is the price at the start date of the project. The unit label (e.g. (GBP/MWh) is automatically created when going through the unit selection, unless “User defined” is chosen in “Payment concerns”. In this case a unit label will be editable, see Figure 2.117, lower part. The content of that label do not influence the calculations and is for reports only.

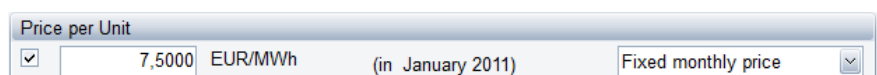

Figure 2.117: The unit price. Upper: Payment concerns are not “User defined”. Lower Payment concerns is “User defined”

Using the drop-down box in the right side of the “Price per Unit” box it is possible to choose between a “Fixed monthly price”, which is as shown in Figure 2.117, and “Variable monthly price”. When set to “Variable monthly price” the input window on the left will change to a drop-down menu from where it is possible to choose between the “Time series” and “Time series functions” in “External conditions” in the Data Input window. This is shown in Figure 2.118.

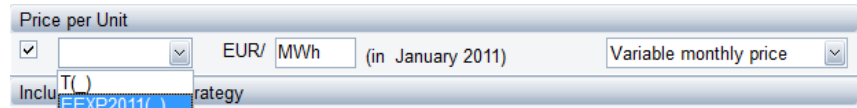

Figure 2.118: Selection of time series as Price per Unit

Include in operation strategy

In the automatic operation strategy in energyPRO, as described in section 2.12, all the revenues and operation expenditures will be taken into account when automatically calculating the operation strategy. However you might want to not include some revenues or expenditures in this calculation. In order to exclude these from the automatic operation strategy you will need to deselect the “Payment included in operation strategy calculation”, as is shown in Figure 2.119.

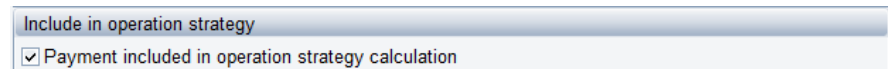

Figure 2.119: Include in operation strategy

Development of unit price (FINANCE AND ACCOUNTS ONLY):

There are three options for the development of the unit price. The “Increased with inflation” is the default setting. The two other options are “Constant” and “Following an Index”

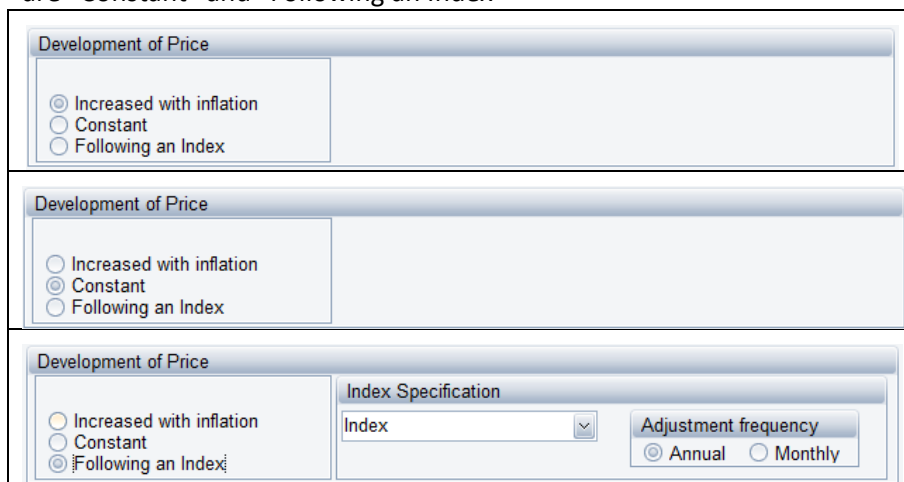

Figure 2.120: Development of unit price – the options

Increased with the inflation: The Inflation “index” selected in the “Economy - Main folder” editing window is used. The adjustment frequency is annual (see below) which means that the amounts are constant on annual basis. The amounts increase with the annual inflation primo the following calculation year.

Constant: The price remains constant.

Following an index: You select one of the indexes that you have created in external conditions.

The image shows a dialog box titled "Index Specification". It contains a dropdown menu labeled "Index" with a downward arrow. To the right of this menu is a section titled "Adjustment frequency" which contains two radio buttons: "Annual" (which is selected) and "Monthly".

Figure 2.121: Index specification

If “Annual” adjustment is selected, the price is constant on annual basis. The amounts increase with the selected index primo the following calculation year. If you select “Monthly”, the price will be adjusted at the beginning of every month.

Payment, Advanced (FINANCE and ACCOUNTS ONLY)

The advanced facility is used in situations, where payments are restricted to a specific period or displaced (delayed) from the month where they physically do occur.

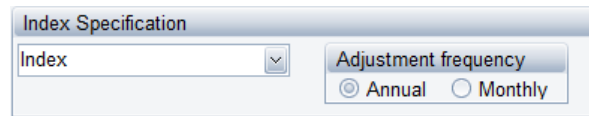
The image shows a panel titled "Advanced" with a checked checkbox. It contains several input fields: "Period:" with two dropdown menus showing "01-01-2012" and "31-12-2012" separated by "to"; "Payment Delayed:" with a dropdown menu showing "1 month"; and "Missing Payment:" with a text input field containing "01-01-2011", a numeric input field containing "23", and the text "EUR".

Figure 2.122: The payment advanced Panel

Period: The period the payments are active. If the fields remain blank no period restrictions will be imposed.

Payment delayed: A payment can be delayed from the month where it physically belongs. The options are: No delay, 1, 2, 3 and 6 months and not paid.

Missing payment: If there is specified a delay for the payment, you can put in the amounts which are delayed from the year before the beginning of the planning period. The delayed amount will be divided equally into the first months (number of Payment delayed months) in the first year.

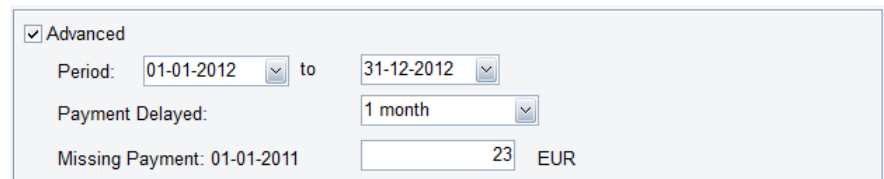
User defined payment selected in “payment concerns”

In the formula field, you can use standard functions such as Min, Max and Exp and you can use one of the special built-in functions listed below. The created formula will generate monthly amounts for each of the month in the year. You can access the available formulas by pressing



. Formulas are added from the list by double clicking.

All built-in functions concerning energy conversion return results in MWh or MW. If you want to use unit prices for fuels or demands in another unit, use the converting functions.

Please note: If you are using “user defined” the payment unit you type in after the value for “Price per year in financial year” DO NOT influence

the calculation at all. The unit is only used to give the user the possibility of having the unit typed on the printouts.

The functions available for defining the payments are shown in the following three tables. In chapter 4 “Function in energyPRO” you find a detailed description of those functions.

Name	Returns	Unit
AccExportedElectricity (Market,PriorityPeriod)	Accumulated monthly amount for exported electricity to market	MWh
AccImportedElectricity (Market,PriorityPeriod)	Accumulated monthly amount for imported electricity from market	MWh
AccImportedFuel(Fuel)	Accumulated monthly amount of imported fuel	MWh
ExportedElectricity(Market, PriorityPeriod)	Electricity exported out of the system to market	MWh/month
PeakExportedElectricity (Market,PriorityPeriod)	Monthly peak value for exported electricity to market	MW
PeakImportedElectricity (Market,PriorityPeriod)	Monthly peak value for imported electricity from market	MW
PeakImportedFuel(Fuel)	Monthly peak value for imported fuel	MW
SpotPricesXExportedElectricity (Market)	Monthly value of electricity exported to the grid from market	<currency used in time series>
SpotPricesXImportedElectricity (Market)	Monthly Value of electricity imported from the grid from market	<currency used in time series>
ImportedElectricity(Market ,PriorityPeriod)	Electricity imported by the system	MWh/month
ImportedFuel(Fuel)	Fuel imported by the system	MWh/month

Table 2.4: Functions measuring the energy passing the system border.

Name	Returns	Unit
HP(eUnit)	Heat production from eUnit	MWh/month
EP(eUnit,PriorityPeriod)	Electricity production from eUnit in Period of priority	MWh/month
CP(eUnit)	Cooling production from eUnit	MWh/month
FC(eUnit)	Fuel consumption on eUnit	MWh/month
EC(eUnit,PriorityPeriod)	Electricity consumption on eUnit in	MWh/month

	Period of priority	
ElectricCapacity(eUnit)	Electric Capacity for eUnit	MW
TurnOns(eUnit)	Number of turn-on for eUnit	
HoursOfOperation(eUnit)	Number of hours of operation for eUnit	Hours

Table 2.5: Functions getting production information on production units.

Name	Returns	Unit
HeatValue (Fuel)	Calorific value for the fuel	MWh/unit
UnitOfDemand(Demand)	Calorific value for the demand (If the unit e.g. are GJ the function will return 0,2777777 MWh/GJ)	MWh/unit
Month(no)	Returns the number 1 for month no, 0 for others	

Figure 2.123: Other functions

2.16 Investment

Investment is available in FINANCE and ACOUNTS only.

The number of investments in a project is unlimited.

Investments:

An investment can consist of one or more payments. The date specified indicates the month, where the investment takes place. All payments are booked primo month.

Investments		
	Date	Amount
1	01-01-2012	1.000.000
2	01-01-2013	1.000.000

Figure 2.124: Investment

Depreciation

The depreciation option is available in ACCOUNTS only.

	Fiscal Year	Depreciation	Left for Depreciation
1			0
2	2012	50.000	950.000
3	2013	100.000	1.850.000
4	2014	100.000	1.750.000
5	2015	100.000	1.650.000
6	2016	100.000	1.550.000
7	2017	100.000	1.450.000
8	2018	100.000	1.350.000

Figure 2.125: Depreciation of investments

Type: There are three types of depreciation options available.

- Linear
- Saldo
- User defined

The table showing the depreciations is updated automatically while changing data.

If user defined is selected the depreciation column in the table will be accessible to input.

Note that you can type in an amount, which is valid at the opening balance, which correspond to an existing asset.

If the amounts left for depreciation is negative this corresponds to depreciation in advance and will be booked in the Balance Sheet as Reserves.

Revaluation of assets:

Figure 2.126: Revaluation of assets.

2.17 Financing

Financing is available in FINANCE and ACOUNTS only.

2.17.1 Financing – Main folder

Cash Account

Specify the annual interest for respectively positive and negative amounts.

Hereto comes that it is possible to specify the content of the cash account at project start.



Cash Account

Annual interest [%] at positive amount:

[%] at negative amount:

Cash account at: 01-01-2012 GBP

Figure 2.127: Financing, cash account

2.17.2 Financing – Loans, Owners capital etc.

The number of financing elements in a project is unlimited.

Financing in an energyPRO project can take place by use of three basic elements: Loan, extraordinary income (e.g. a grant) or owner's capital. All these elements are added by selecting financing and add new financing. In all cases the same default editing window is shown, see Figure 2.128

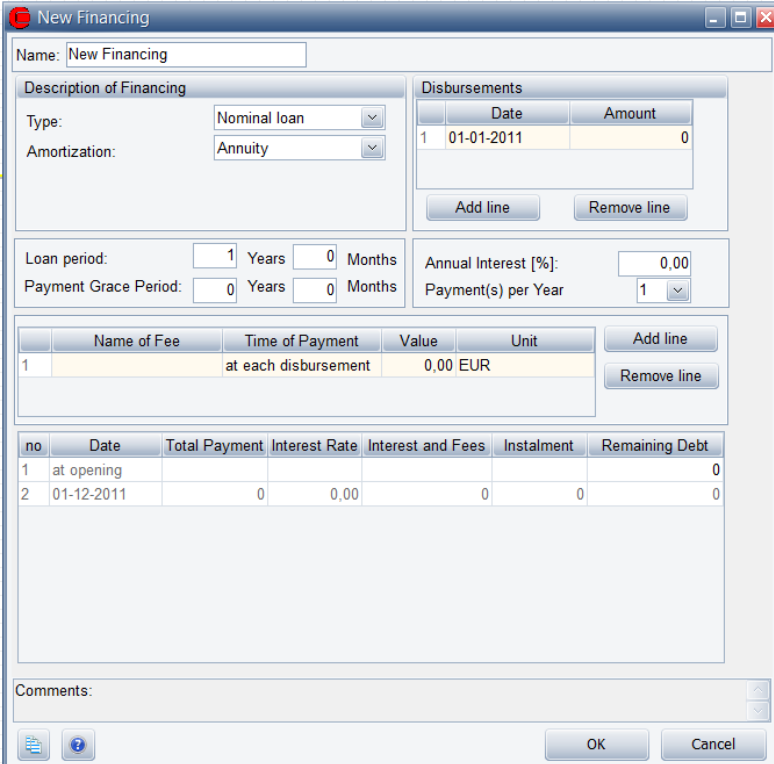

New Financing

Name:

Description of Financing

Type:

Amortization:

Disbursements

	Date	Amount
1	01-01-2011	0

Add line Remove line

Loan period: Years Months

Payment Grace Period: Years Months

Annual Interest [%]:

Payment(s) per Year:

	Name of Fee	Time of Payment	Value	Unit
1		at each disbursement	0,00	EUR

Add line Remove line

no	Date	Total Payment	Interest Rate	Interest and Fees	Instalment	Remaining Debt
1	at opening					0
2	01-12-2011	0	0,00	0	0	0

Comments:

OK Cancel

Figure 2.128: Financing default editing window

Description of financing

Type: There are five financing options available.

Three loan-types:

- Nominal Loan
- Foreign Loan
- Indexed Loan

Hereto comes

- Owners Capital
- Extraordinary income

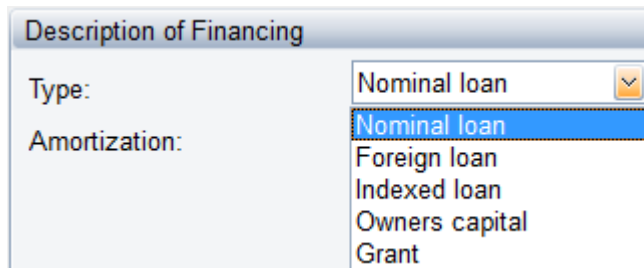

The screenshot shows a dialog box titled "Description of Financing". It has two main sections: "Type:" and "Amortization:". The "Type:" dropdown menu is currently set to "Nominal loan". The "Amortization:" dropdown menu is open, displaying a list of options: "Nominal loan", "Foreign loan", "Indexed loan", "Owners capital", and "Grant". The "Nominal loan" option in the list is highlighted with a blue background.

Figure 2.129: Description of financing: types

If “Foreign Loan” or “Index Loan” is selected an index is required. This mean that an index established under “External conditions” has to be in place.

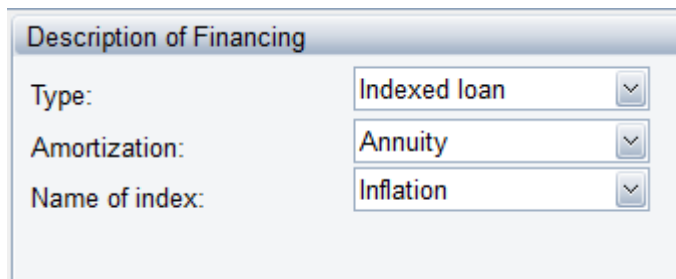

The screenshot shows the "Description of Financing" dialog box with three dropdown menus. The "Type:" dropdown is set to "Indexed loan". The "Amortization:" dropdown is set to "Annuity". The "Name of index:" dropdown is set to "Inflation".

Figure 2.130: Description of financing: connect to index

Amortization: There are three options available. “Annuity”, “Serial” and “User defined”. If “User defined” is chosen you get access to type in your own amounts for payments and Interest rate in the payment overview table at the bottom of the window.

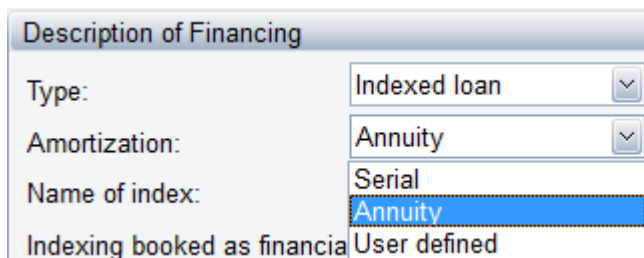

The screenshot shows the "Description of Financing" dialog box. The "Type:" dropdown is set to "Indexed loan". The "Amortization:" dropdown is set to "Annuity". The "Name of index:" dropdown is open, showing options: "Serial", "Annuity", and "User defined". The "Annuity" option is highlighted. Below the dropdowns, there is a checkbox labeled "Indexing booked as financial expenses" which is checked.

Figure 2.131: Description of financing: Amortization types.

Indexing booked as financial expenses: This option does appear when “Indexed loan” is selected in an ACCOUNTS-project.

Description of Financing

Type: Indexed loan

Amortization: Annuity

Name of index: Inflation

Indexing booked as financial expense: 40 [%]

Figure 2.132: Description of financing: Amortization type with indexing chosen.

The Indexing can be booked in one of the following ways:

- As a financial expenditure in the Income Statement
- As a fixed asset in the Balance sheet and depreciated through the loan period
- As a mixture of the above possibilities

The percentage stated indicates which of the possibilities you select. For instance 40 % means, that 40 % of the indexing amount will be booked as a financial expenditure in the Income Statement while the rest will be booked as a fixed asset in the Balance sheet and depreciated through the loan period.

Disbursements:

Disbursements are in calculations assumed to take place at the primo month.

Disbursements

	Date	Amount
1	01-01-2012	500.000
2	01-01-2013	200.000

Add line Remove line

Figure 2.133: Financing disbursements

Fees:

In this table it is possible to type in as many fees as wanted. Give every fee a describing name.

	Name of Fee	Time of Payment	Value	Unit	Add line
1	DisbursementFee	at each disburseme	0,25 % of Disbursement		Remove line

Figure 2.134: Financing fee

The fee can be paid along with disbursements or repayments. For a loan with only one disbursement, this will typically be a fee connected to the creation of the loan. A fee paid at repayment could e.g. be a fee for administrating the loan.

Payment overview

This table is updated every time you alter one of the values above.

The total payment consists of interest, fee and instalment. The interest percentage stated in this table is the interest percentage for the settled period for payment calculated by use of the annual rate stated. The remaining debt is calculated as the remaining debt after the last payment minus the instalment. If the loan type is "Foreign Loan" or "Index Loan" the remaining debt will be increased by the selected index before calculating interest and a new remaining debt.

no	Date	Total Payment	Interest Rate	Interest and Fees	Instalment	Remaining Debt
1	at opening					0
2	01-12-2012	51.000	0,00	0	51.000	459.000
3	01-12-2013	74.687	0,00	0	74.687	597.493
4	01-12-2014	76.180	0,00	0	76.180	533.263
5	01-12-2015	77.704	0,00	0	77.704	466.224
6	01-12-2016	79.258	0,00	0	79.258	396.290
7	01-12-2017	80.843	0,00	0	80.843	323.373
8	01-12-2018	82.460	0,00	0	82.460	247.380

Figure 2.135: Financing overview table

If user defined loan is chosen the three columns "Date", "Total payment" and "Interest rate" will be accessible for input as shown on Figure 2.136.

no	Date	Total Payment	Interest Rate	Interest and Fees	Instalment	Remaining Debt
1	at opening					0
2	01-12-2012	51.000	0,00	0	51.000	459.000
3	01-12-2013	74.687	0,00	0	74.687	597.493
4	01-12-2014	76.180	0,00	0	76.180	533.263
5	01-12-2015	77.704	0,00	0	77.704	466.224
6	01-12-2016	79.258	0,00	0	79.258	396.290
7	01-12-2017	80.843	0,00	0	80.843	323.373
8	01-12-2018	82.460	0,00	0	82.460	247.380

Figure 2.136: Financing overview table User defined loan

Remark, it is possible to fill in a beginning remaining debt in the table.

2.18 Taxation

You can add one or more taxations to a project just as with investments or financing. You can e.g. build up taxation, which consists of among other a tax payment to the state and a tax payment to the county.

Tax is assumed to be paid once a year in a given month in the following fiscal year.

Tax payment is reduced by Loss Carried Forward

In this standard situation, you can turn into account the loss from a number of previous years. Specify the tax rate and the number of years from which you can utilize eventual losses.

Name: Taxation

Taxation

Tax payment is:

reduced by Loss Carried Forward
 user defined

Tax is paid in next financial year in: January

Tax rate: 25,0 %
Loss carried forward: 1 Years

Tax formula:
25/100*Max(ResultBeforeTax-LossCarriedForward(1);0)

Figure 2.137: Taxation. Loss carried forward

Remark the window “Tax formula” in which you can see the actual formula corresponding to the specified data. The window is grey and inaccessible unless you select “User defined”.

Tax payment is User Defined:

If you have selected “User defined” in the window “Tax payment” you get access to the formula window.

Name: Taxation

Taxation

Tax payment is:

reduced by Loss Carried Forward
 user defined

Tax is paid in next financial year in: January

Tax formula:
25/100*Max(ResultBeforeTax-LossCarriedForward(1);0)

Figure 2.138: Taxation User defined.

In the formula, you can use standard expressions and functions as Min, Max and Exp etc. In addition, you can use one of the special built-in functions listed below.

Name	Returns
ResultBeforeTax	The result of the actual fiscal year before tax
LossCarriedForward(n)	The last n years loss reduced with eventually profits from the fiscal years
Increment(amount;n1;n2)	This function increments from zero with the value “amount” from fiscal year n1 to n2. Example : Increment(10;2;4) gives the result Fiscal year 1 : 0 Fiscal year 2 : 10 Fiscal year 3 : 20

	Fiscal year 4 : 30 Fiscal year 5 : 30
Year(n)	1 in the fiscal year n, 0 otherwise Example : Year(1)+Year(2) returns 1 in first and second fiscal year, 0 otherwise

Table 2.6: Taxation functions available for user-defined formulas.

Examples:

Example 1: Loss carried forward: Standard situation with 30 % tax and the right to make use of losses from the three previous years:

→ Formula = $30.0/100 * \text{Max}(\text{ResultBeforeTaxLossCarriedForward}(3);0)$

Example 2: If the company is a department of a larger company, the larger company can use a negative result from the department to reduce the tax. In this case, the tax will be paid into the department in years with negative result.

→ Formula = $0.25 * \text{ResultBeforeTax}$

Example 3: The tax percentage starts with 30.0 and increase with 1 from the second fiscal year and over the next 4 years:

→ Formula = $(30.0 + \text{Increment}(1.0;2;5))/100 * \text{Max}(\text{ResultBeforeTax};0)$

Example 4: The project is tax-free the first two years and hereafter the tax percentage is 30 %:

Formula = $(\text{Increment}(30;3;3))/100 * \text{Max}(\text{ResultBeforeTax};0)$

2.19 Reports

2.19.1 Introduction

There are a number of financial and technical reports available in energyPRO. The actual available reports are depending on which energyPRO module, that is selected, the types of energy demands in the project and the selected operation strategy.

The reports are context sensitive, which primarily means that irrelevant information is excluded. For instance information about thermal stores are not shown if there are no thermal stores in the project and the report “Duration curve for cooling demand” is not available if no cooling demand is present.

The available reports in energyPRO with the ACCOUNTS module chosen are shown in Figure 2.139.

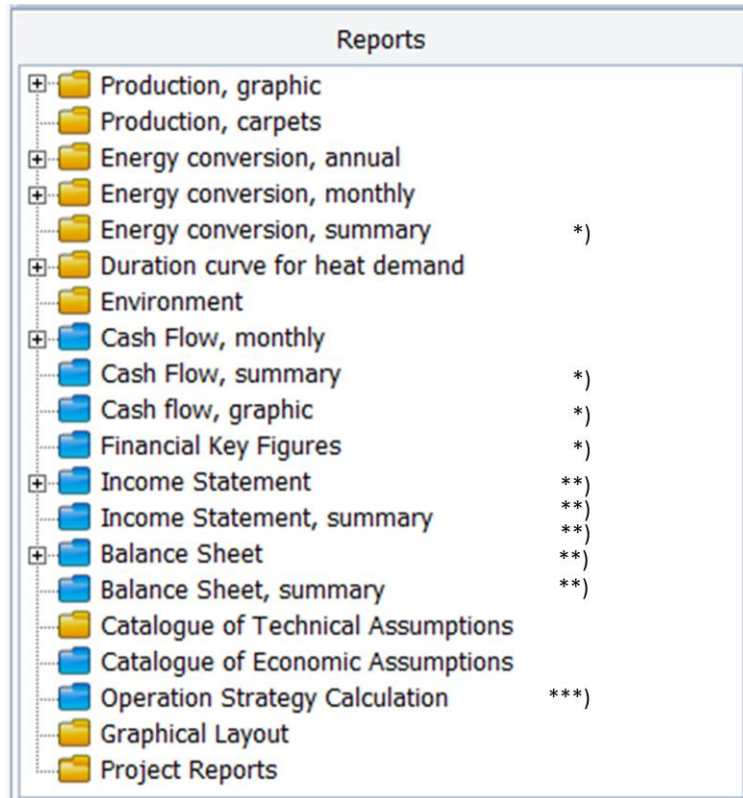

Figure 2.139: The Reports available in energyPRO (ACCOUNTS module chosen)

*) Reports are available in FINANCE and ACCOUNTS

***) Reports are available in ACCOUNTS only.

***) Operation Strategy Calculation is available only if the operation strategy selected as auto calculated in "Operation strategy".

Hereto come that the duration curves are only shown if the specific demand type is present in the project

The technical reports are represented with yellow folders and the economical with blue folders.

Report Header information

Common for all the reports are the report header. The information found in these headers is shown in Figure 2.140. The following numbers are referring to the figure.

1. The name of your project file (extension excluded)
2. Project Information given in the Project Identification editing window
3. The name of the report
4. Date and time for report generation
5. Your registration information
6. Your company logo, if chosen as described in section 2.2.1



Figure 2.140: Header information in reports

2.19.2 Reports to Clipboard

All the reports can be copied to clipboard as graphic by entering a button that copies the report to the clipboard. Most of the reports also have a data export button. If this button is selected the data is copied to the clipboard ready for copying into a spread sheet for instance Excel.

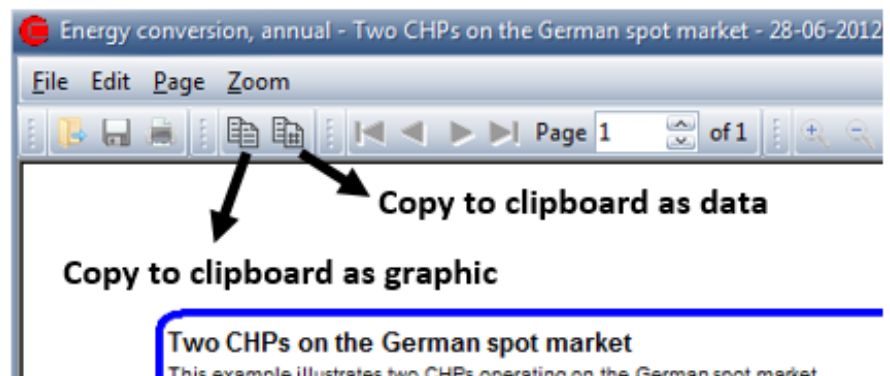



Figure 2.141: It is possible to copy reports to clipboard either as data or as graphics.

2.19.3 Production, Graphical

This graphs included in this report depend on the content of your project. The graphs are as follows:

- External conditions
- Priorities of the individual production units
- Heat production (if Heat production)
- Electricity Production (if Electricity production)
- Cooling Production (if cooling production)
- Fuels
- Thermal storage (if a Thermal storage is used)
- Fuel storage (if fuel storage is used)
-

The report shown in Figure 2.142 shows the production of a CHP-plant in a week in April.

The report is invoked by pressing the  button. Hereafter the report will be shown. Some reports require selections in a simple setup window before being shown.

Two CHPs on fixed tariffs

This example illustrates a cogeneration plant selling and buying its electricity on a fixed tariff market.
1 GBP is approx. equal to 1.5 EUR.

Printed Page
30-10-2013 14:58:44 / 1
Licensee:
EMD International A/S
Niels Jernes Vej 10
DK-9220 Aalborg Ø
+45 9835 4444

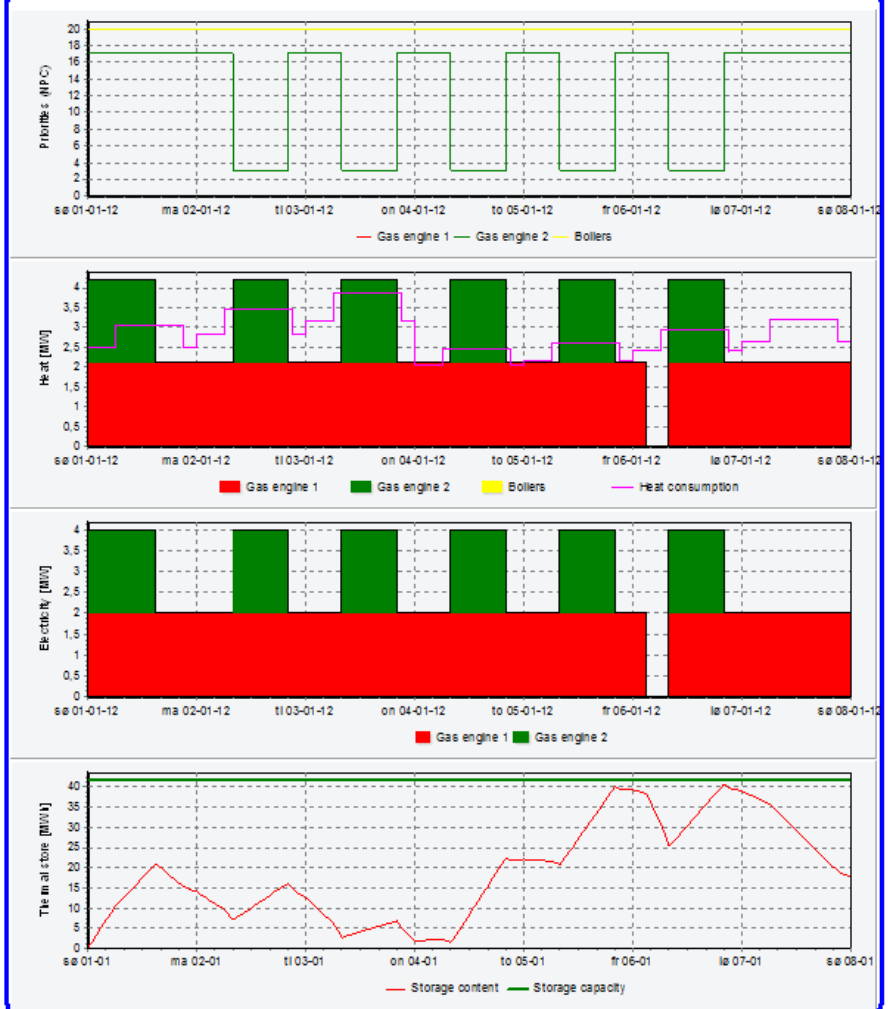
Production, graphic 2012/2012

energyPRO is developed by EMD International A/S, Niels Jernesvej 10, DK-9220 Aalborg Ø, Tlf. +45 9835 4444, Fax +45 9835 4445, Homepage: www.emd.dk

Figure 2.142: Production graphical report

The upper graph shows the priorities, which are used for optimization, the next shows the heat production, the third the electricity production. Finally the last shows the development in the content of the thermal store.

2.19.4 Production, carpets

When selecting the report "Production, carpets" a selection window appear.

- Select Site. Select a specific site or combined (REGION only)
- Select Year. The year you want to see the carpet view for.

- Select Item. Click the item in one of the tables. E.g. Gas engine 1 in the electricity production column.

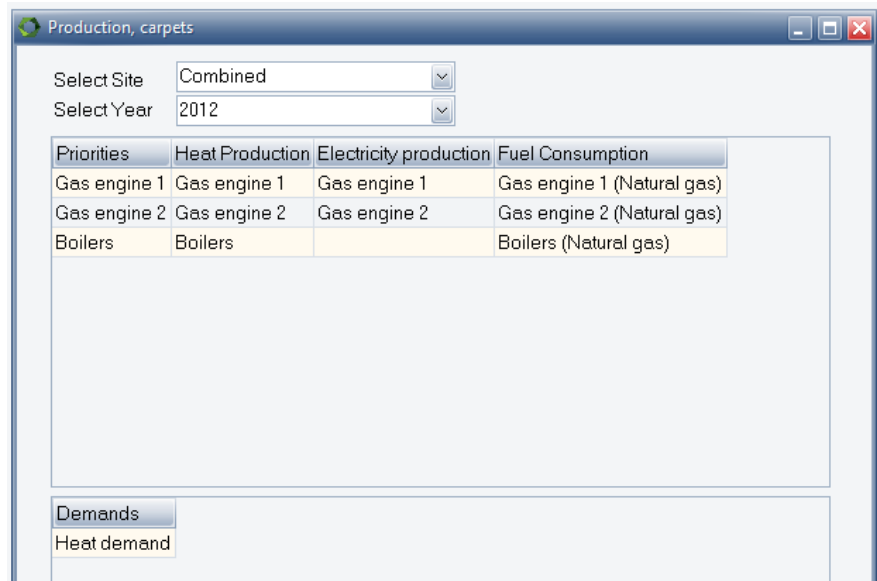

Figure 2.143: Production carpets selection window

When the Item is clicked in the table the corresponding carpet view will appear as seen below.

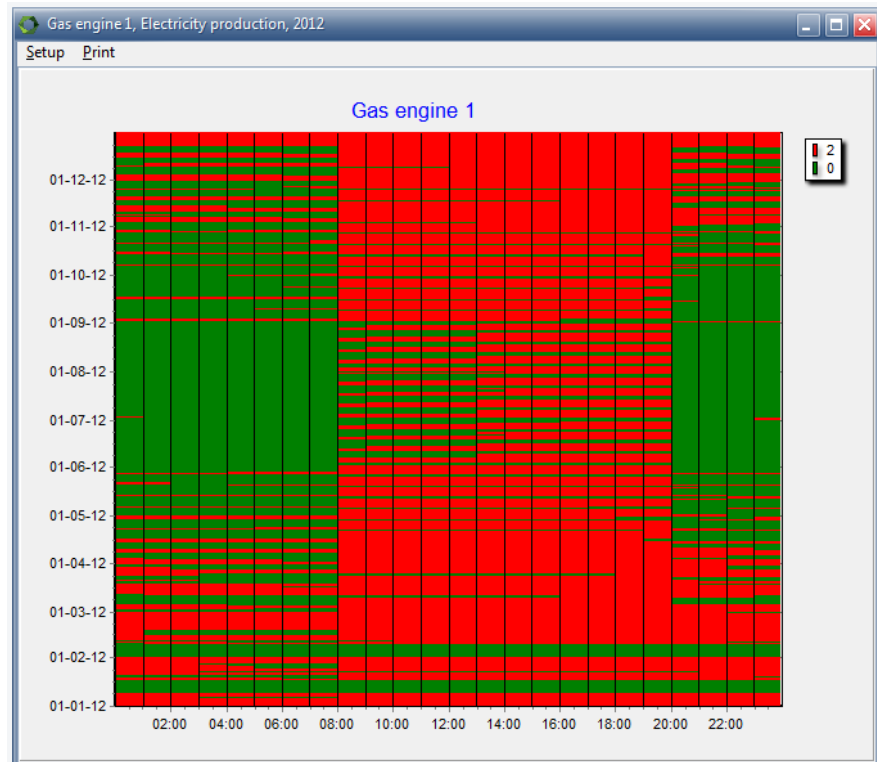

Figure 2.144: Production carpets. Example showing electricity production

This view has a setup option and a print option. Selecting the setup option you have access to some basic design options for the view. See also the description in the time series in the input data section.

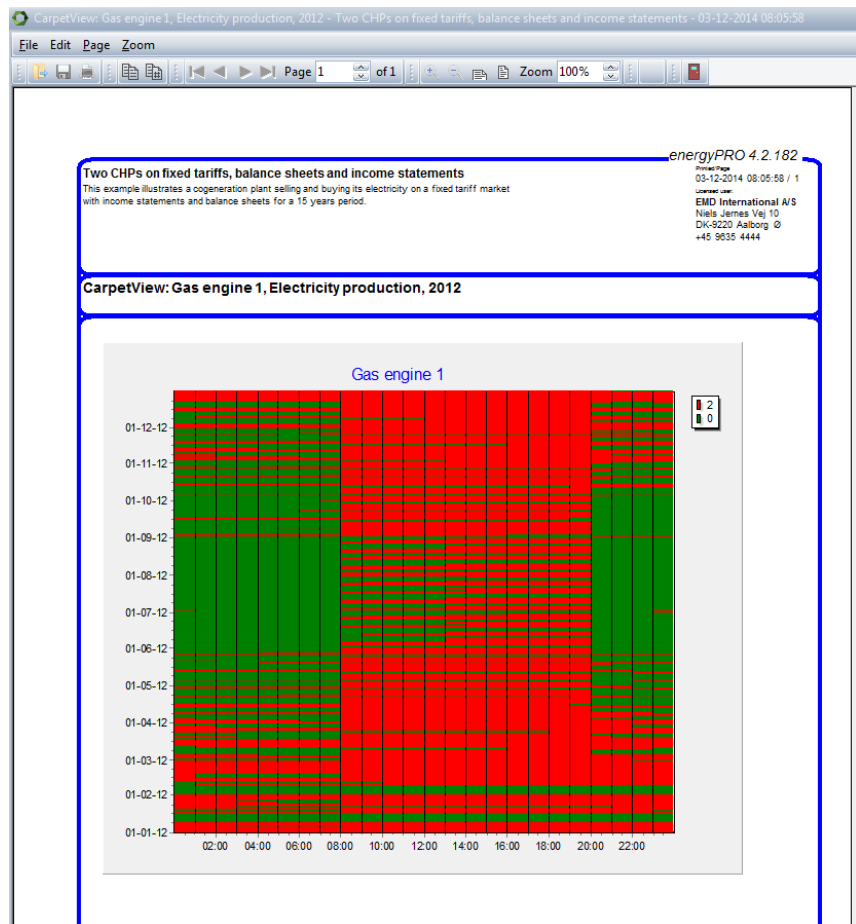

Figure 2.145: Production carpets. Example showing electricity production as report

At present it is NOT possible to include this report in project reports.

2.19.5 Energy conversion annual

This report shows the energy conversion on annual basis. The content of the report is:

- Demands
- Productions
- Transmissions
- Losses
- Hours of operations
- Number of Turn-on
- Fuel consumptions

If "fixed tariffs" is defined in "Electricity market" the electricity production will be distributed in the defined tariff periods.

Two CHPs on fixed tariffs

This example illustrates a cogeneration plant selling and buying its electricity on a fixed tariff market
1 GBP is approx. equal to 1.5 EUR.

Printed Page
30-10-2013 15:01:23 / 1
Licenceholder:
EMD International A/S
Niels Jernes Vej 10
DK-9220 Aalborg Ø
+45 9635 4444

Energy conversion, annual

Calculate period: 01-2012 - 12-2012

Heat demands:

Total sale of heat	12,000,0 MWh
Network loss	3,000,0 MWh
Total	15,000,0 MWh
Max heat demand	4,2 MW

Heat productions:

Gas engine 1	10,188,3 MWh/year	67,8%
Gas engine 2	4,312,8 MWh/year	28,8%
Boilers	519,1 MWh/year	3,5%
Total	15,000,0 MWh/year	100,0%

Electricity produced by energy units:**Fixed tariffs:**

	Day [MWh/year]	Night [MWh/year]	All periods [MWh/year]	Of annual production
Gas engine 1	5,670,0	3,950,0	9,620,0	70,2%
Gas engine 2	3,854,0	420,0	4,080,0	29,8%
Total	9,524,0	4,370,0	13,700,0	100,0%
Of annual production	68,1%	31,9%	100,0%	

Peak electricity production:

Gas engine 1	2,000,0 kW-elec.
Gas engine 2	2,000,0 kW-elec.

Hours of operation:**Fixed tariffs:**

	Day [h/Year]	Night [h/Year]	Total [h/Year]	Of annual hours
Gas engine 1	2,935,0	1,975,0	4,810,0	54,6%
Gas engine 2	1,827,0	213,0	2,040,0	23,2%
Out of total in period	3,132,0	5,652,0	8,784,0	

Production unit(s) Not connected to electricity market:

	Total [h/Year]	Of annual hours
Boilers	308,0	3,7%
Out of total in period	8,784,0	

Turnons:

Gas engine 1	239
Gas engine 2	173
Boilers	16

Fuels:**By fuel**

Natural gas	Fuel consumption 3,329,579,2 Nm ³
-------------	---

By energy unit

Gas engine 1	25,334,3 MWh	=2,303,115,5 Nm ³
Gas engine 2	10,744,7 MWh	=978,789,1 Nm ³
Boilers	548,4 MWh	=49,874,6 Nm ³
Total	36,625,4 MWh	

energyPRO developed by EMD International A/S, Niels Jernes Vej 10, DK-9220 Aalborg Ø, Tlf. +45 9635 4444, Fax +45 96 36 44 45, Homepage: www.emd.dk

Figure 2.146: Energy Conversion, Annual report

2.19.6 Energy Conversion, monthly

This report includes the same information as the “Energy conversion, annual” report, although the structure is a bit different and it includes monthly values for the energy conversion. Where the annual report is organized by demands and productions this report is on the other hand structured by Production units and fuels.

energyPRO 4.2.182
Printed: 30-10-2013 15:04:28 / 1
Licensee: EMD International A/S
Niels Jernes Vej 10
DK-9220 Aalborg Ø
+45 9835 4444

Two CHPs on fixed tariffs
This example illustrates a cogeneration plant selling and buying its electricity on a fixed tariff market
1 GBP is approx. equal to 1.5 EUR.

Energy conversion, monthly

Calculate period: 01-2012 - 12-2012

	Total	jan	feb	mar	apr	maj	jun	jul	aug	sep	okt	nov	dec
Heat demand [MWh]	15.000,0	2.008,7	1.866,0	1.750,7	1.441,5	1.152,4	442,6	457,4	457,4	816,0	1.184,7	1.574,6	1.858,0
Electricity produced by energy units [MWh]	13.700,0	1.844,0	1.346,0	1.866,0	1.352,0	1.084,0	418,0	432,0	440,0	760,0	1.130,0	1.504,0	1.724,0
Day	9.324,0	912,0	720,0	1.056,0	924,0	888,0	418,0	428,0	440,0	592,0	894,0	1.044,0	1.008,0
Night	4.376,0	932,0	626,0	810,0	428,0	196,0	0,0	4,0	0,0	168,0	236,0	460,0	716,0
Exported electricity, Fixed tariffs [MWh]	13.700,0	1.844,0	1.346,0	1.866,0	1.352,0	1.084,0	418,0	432,0	440,0	760,0	1.130,0	1.504,0	1.724,0
Day	9.324,0	912,0	720,0	1.056,0	924,0	888,0	418,0	428,0	440,0	592,0	894,0	1.044,0	1.008,0
Night	4.376,0	932,0	626,0	810,0	428,0	196,0	0,0	4,0	0,0	168,0	236,0	460,0	716,0
Peak [MW]	4,000	4,000	4,000	4,000	4,000	4,000	4,000	2,000	2,000	4,000	4,000	4,000	4,000
Energy unit: Gas engine 1													
Fuel consum. [Nm3]	2.303.115,5	238.451,5	222.171,6	272.447,5	223.129,3	179.078,0	98.157,7	103.424,7	105.340,0	155.137,1	188.854,4	236.536,2	280.587,5
Fuel consum. [MWh]	25.334,3	2.623,0	2.443,9	2.996,9	2.454,4	1.969,9	1.079,7	1.137,7	1.153,7	1.706,5	2.075,2	2.501,9	3.086,5
Heat prod. [MWh]	10.168,3	1.052,8	980,9	1.202,9	985,1	790,6	433,4	456,6	465,1	684,9	832,9	1.044,3	1.238,8
Elec. prod. [MWh]	9.620,0	996,0	928,0	1.138,0	932,0	748,0	410,0	432,0	440,0	648,0	788,0	988,0	1.172,0
Turnons	239	9	6	19	22	27	21	23	22	25	27	21	17
Operating hours	4.810	498	464	569	466	374	205	216	220	324	394	494	598
Full load operating hours	4.810	498	464	569	466	374	205	216	220	324	394	494	598
Energy unit: Gas engine 2													
Fuel consum. [Nm3]	976.789,1	203.018,9	100.073,0	126.408,0	100.551,8	80.441,5	1.915,3	0,0	0,0	26.813,8	81.877,9	123.535,1	132.153,8
Fuel consum. [MWh]	10.744,7	2.233,2	1.100,8	1.390,5	1.106,1	884,9	21,1	0,0	0,0	295,0	900,7	1.358,9	1.453,7
Heat prod. [MWh]	4.312,6	896,3	441,8	558,1	443,9	355,2	8,5	0,0	0,0	118,4	361,5	545,4	583,5
Elec. prod. [MWh]	4.080,0	848,0	418,0	528,0	420,0	330,0	8,0	0,0	0,0	112,0	342,0	516,0	552,0
Turnons	173	17	17	22	20	21	1	0	0	11	20	22	22
Operating hours	2.040	424	209	264	210	168	4	0	0	56	171	258	276
Full load operating hours	2.040	424	209	264	210	168	4	0	0	56	171	258	276

energyPRO is developed by EMD International A/S, Niels Jernesvej 10, DK-9220 Aalborg Ø, Tlf +45 9835 4444, Fax +45 9835 4446, Homepage: www.emd.dk

Figure 2.147: Energy conversion, Monthly report

2.19.7 Energy Conversion, summary

This report is available if the FINANCE or the ACCOUNT module is chosen. This report is structured as the “Energy conversion, monthly” report except that the values in this report is shown annually.

energyPRO 4.2.182
Printed: 30-10-2013 15:07:30 / 1
Licensee: EMD International A/S
Niels Jernes Vej 10
DK-9220 Aalborg Ø
+45 9835 4444

Two CHPs on fixed tariffs
This example illustrates a cogeneration plant selling and buying its electricity on a fixed tariff market
1 GBP is approx. equal to 1.5 EUR.

Energy conversion, summary

Heat demand [MWh]	2012	15.000
Electricity produced by energy units [MWh]		13.700
Day		9.324
Night		4.376
Exported electricity [MWh]		13.700
Day		9.324
Night		4.376
Peak [MW]		4,000
Energy unit: Gas engine 1		
Fuel consum. [Nm3]	2.303.115	
Fuel consum. [MWh]	25.334	
Heat prod. [MWh]	10.168	
Elec. prod. [MWh]	9.620	
Turn ons	239	
Operating hours	4.810	
Energy unit: Gas engine 2		
Fuel consum. [Nm3]	976.789	
Fuel consum. [MWh]	10.745	
Heat prod. [MWh]	4.313	
Elec. prod. [MWh]	4.080	
Turn ons	173	
Operating hours	2.040	

energyPRO is developed by EMD International A/S, Niels Jernesvej 10, DK-9220 Aalborg Ø, Tlf +45 9835 4444, Fax +45 9835 4446, Homepage: www.emd.dk

Figure 2.148: Energy conversion, summary

2.19.8 Duration curves for Demands

There are demand curves available for the types of demand defined in the project.

Figure 2.149 show an example of a duration curve for heat demand. To the left is shown the duration curve. To the right is the productions shown. The watchful observer will notice that the productions do not hour by hour match the demands. The reason is that a thermal store is displacing productions in order to operate the plant more efficiently.

The report is invoked by pressing the  button

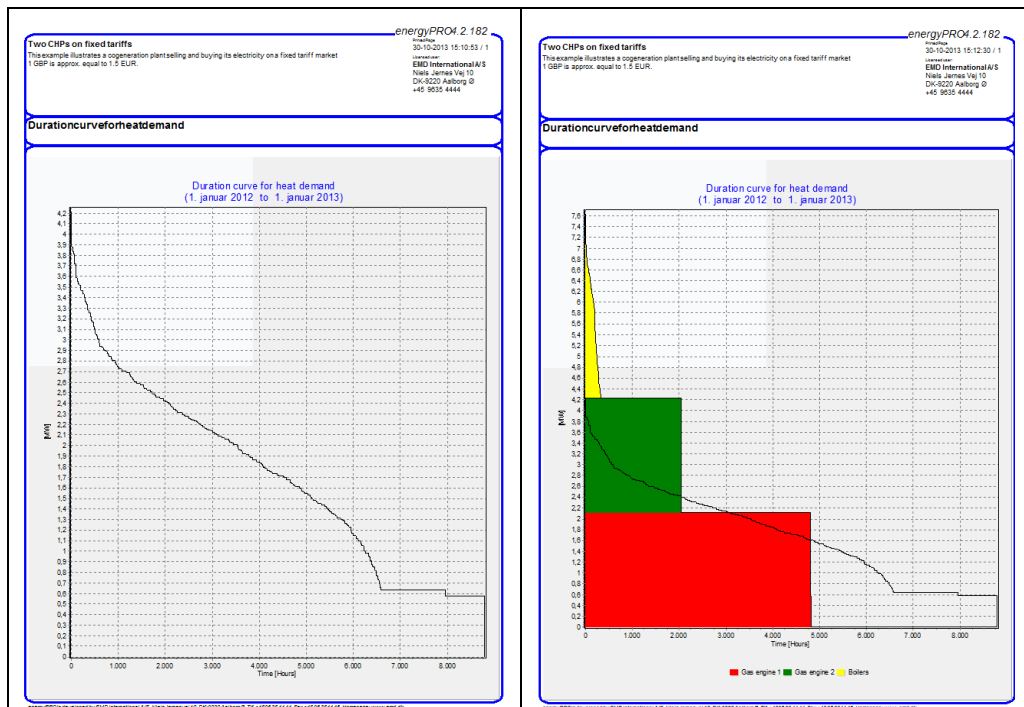

Figure 2.149: Duration curve for heat demand (left). Demand curve for heat demand with productions included (right)

2.19.9 Environment

The environment report is based on the information you defined in your environment input data folder.

energyPRO4.2.182
Printed: 30-10-2013 15:14:07 / 1
License user: EMD International A/S
Niels Jernes Vej 10
DK-9220 Aalborg Ø
+45 9835 4444

Two CHPs on fixed tariffs
This example illustrates a cogeneration plant selling and buying its electricity on a fixed tariff market
1 GBP is approx. equal to 1.5 EUR.

Environment

Emissions

	2012
CO2 [ton]	
All Production units	7.558
CO2 Total	7.558
NOx [kg]	
Engines	33.487
Existing boilers	258
NOx Total	33.785
SO2 [kg]	
All Production units	33
SO2 Total	33

Figure 2.150: Environment report

2.19.10 Economy Reports introduction

The available reports are module-dependent. As shown in Figure 2.151 there are two reports concerning economy available in all modules, “Cash flow, Monthly”, and “Catalogue of economical Assumptions”. If the FINANCE-module is chosen additional three reports are optional. This is “Cash flow, summary”, “Cash flow, Graphical” and “financial key-numbers”. Finally, further four reports are optional if the ACCOUNTS-module is chosen. This is “Income Statement”, “Income Statement, Summary”, “Balance Sheet” and “Balance Sheet, Summary”

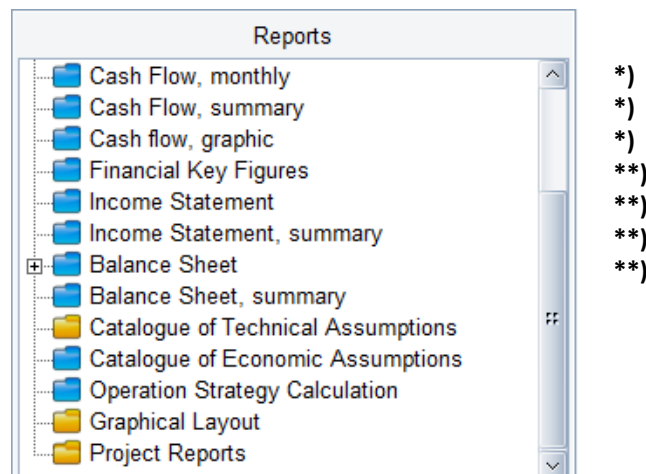

Figure 2.151: Reports financial

When previewing the economy reports you have some setup options:

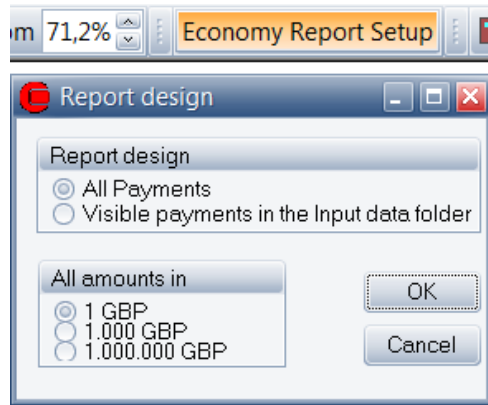

Figure 2.152: Economy report design window

The first option is to state if you will see all the payments, you defined in your economy input data folders or only those visible in the input data folder structure. The second option is to set up the amount used in the reports.

If the “Visible payments in the input data folder structure” is marked, the report will be different in the two cases shown in

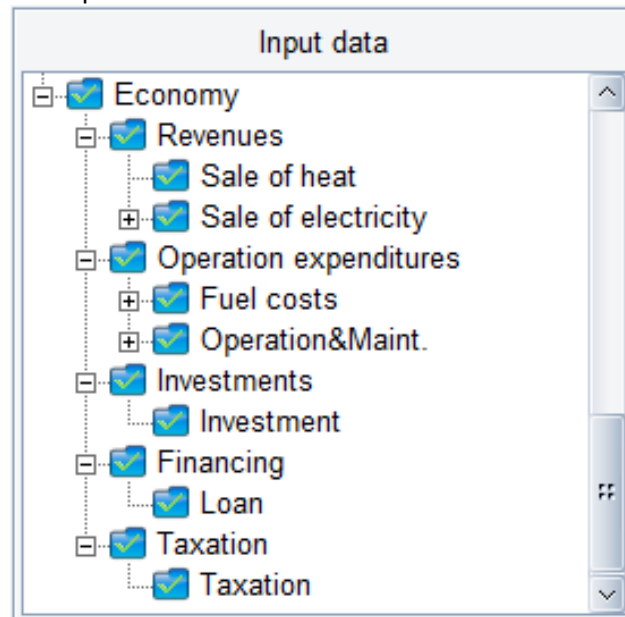

Figure 2.153. The project economy is the same but some of the folders are collapsed to the right, and the report will be more aggregated for instance having only one line for “sale of electricity”, while the one to the left are showing the electricity sale in day and night tariffs.

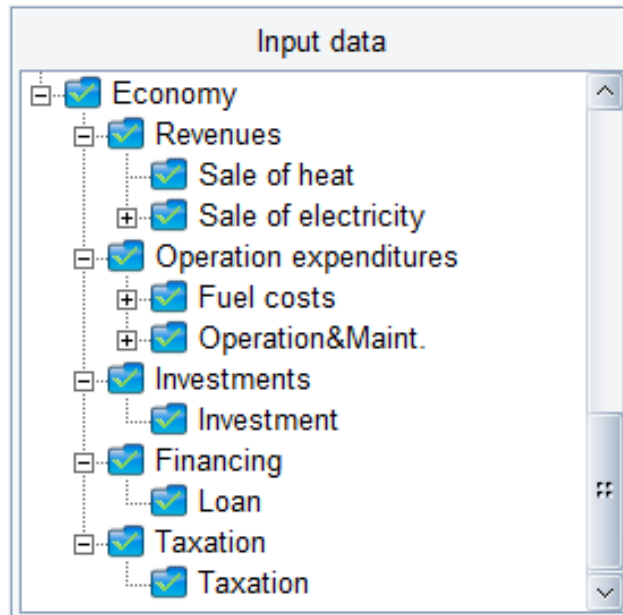

Figure 2.153: Designing economy reports using the economy input data folder structure as organizer. Require that the “visible in the input data folder structure”- option is set

2.19.11 Operation income

This report is available in DESIGN only. It includes all operational payments, i.e. revenues and operating expenditures.

energyPRO4.2.182
PrintedPage
30-10-2013 15:21:43 / 1
User: user
EMD International A/S
Niels Jernes Vej 10
DK-9220 Aalborg Ø
+45 9835 4444

Two CHPs on fixed tariffs
This example illustrates a cogeneration plant selling and buying its electricity on a fixed tariff market
1 GBP is approx. equal to 1.5 EUR.

OperationIncome from 01-01-2012 00:00 to 31-12-2012 23:59

(All amounts in 1000 GBP)

Revenues						
Sale of heat	:	12.000,0 MWh	at	0,025	=	300
Sale of electricity						
Day	:	9.324,0 MWh	at	0,05	=	466
Night	:	4.376,0 MWh	at	0,035	=	153
Sale of electricity Total						619
Total Revenues						919
OperatingExpenditures						
Fuel costs						
Natural gas	:	3.329.579,2 Nm3	at	0,0	=	666
Climate changelevy	:	3.329.579,2 Nm3	at	0,0	=	0
Fuel costs Total						666
Operation&Maint.						
Engine 1	:	9.620,0 MWh	at	0,005	=	48
Engine 2	:	4.090,0 MWh	at	0,005	=	20
Boilers	:	519,1 MWh	at	0,0	=	0
Operation&Maint. Total						69
Total Operating Expenditures						735
OperationIncome						185

Figure 2.154: Operation income report.

2.19.12 Cash flow, monthly

The cash flow, monthly report includes all payments in a project in the month that the payments take place. The payments include

- Operational payments
 - Revenues
 - Operating expenditures

- Investments
- Financial payments
- Eventually tax payments
- Interest on cash account

energyPRO4.2.182
Printed: 30-10-2013 15:23:28 / 1
User: emd
EMD International A/S
Niels Jernes Vej 10
DK-9220 Aalborg Ø
+45 9635 4444

Two CHPs on fixed tariffs
This example illustrates a cogeneration plant selling and buying its electricity on a fixed tariff market
1 GBP is approx. equal to 1.5 EUR.

CashFlow, monthly

Calculated Period: 01-2012 - 12-2012
(All amounts in 1000 GBP)

	Total	jan	feb	mar	apr	maj	jun	jul	aug	sep	okt	nov	dec
Revenues													
Sale of heat	300	44	40	37	30	22	5	5	5	14	23	33	40
Sale of electricity													
Day	488	46	38	53	48	44	21	21	22	30	45	52	50
Night	153	33	22	21	15	7	0	0	0	8	8	16	25
Sale of electricity Total	619	78	58	74	61	51	21	22	22	35	53	68	75
Total Revenues	919	122	98	112	91	74	26	27	27	50	76	102	116
OperatingExpenditures													
Fuel costs													
Natural gas	666	90	72	80	65	52	20	21	21	36	54	72	83
Climate change levy	0	0	0	0	0	0	0	0	0	0	0	0	0
Fuel costs Total	666	90	72	80	65	52	20	21	21	36	54	72	83
Operation&Maint.													
Engine 1	48	5	5	6	5	4	2	2	2	3	4	5	6
Engine 2	20	4	2	3	2	2	0	0	0	1	2	3	3
Boilers	0	0	0	0	0	0	0	0	0	0	0	0	0
Operation&Maint. Total	69	9	7	8	7	5	2	2	2	4	6	8	9
Total Operating Expenditures	735	99	79	88	72	57	22	23	23	40	60	80	91
Net Cash from Operation	185	23	19	23	20	16	4	4	4	10	16	22	24
Cash Account	185	23	42	65	85	101	105	109	112	122	138	160	185

energyPRO is developed by EMD International A/S, Niels Jernesvej 10, DK-9220 Aalborg Ø, Tel: +45 96 36 44 44, Fax: +45 96 36 44 45, Homepage: www.emd.dk

Figure 2.155: Cash flow monthly report

Cash flow summary

The cash flow, summary report includes all payments in a project in the year that the payments take place as with the cash flow, monthly report. The only difference is that the columns are annual numbers instead of monthly

2.19.13 Cash flow, graphical

This report is invoked by pressing the  button

This report shows the development in the cash flow shown graphically. In the example shown in Figure 2.156 shows that the cash account exceeds the debt early 2020 and thereby has an expected payback time of about eight years. The downward going line represents the remaining debt and the upward going line shows the cash account

Two CHPs on fixed tariffs, balance sheets and income statements

This example illustrates a cogeneration plant selling and buying its electricity on a fixed tariff market with income statements and balance sheets for a 15 years period.

PrintedPage
30-10-2013 15:32:09 / 1
User: user
EMD International A/S
Niels James Vej 10
DK-9220 Aalborg Ø
+45 9835 4444

Cashflow, graphic

Figure 2.156: Cash flow graphics report

2.19.14 Financial key figures

This report states the key financial figures used, as shown in Figure 2.157.

Two CHPs on fixed tariffs, balance sheets and income statements

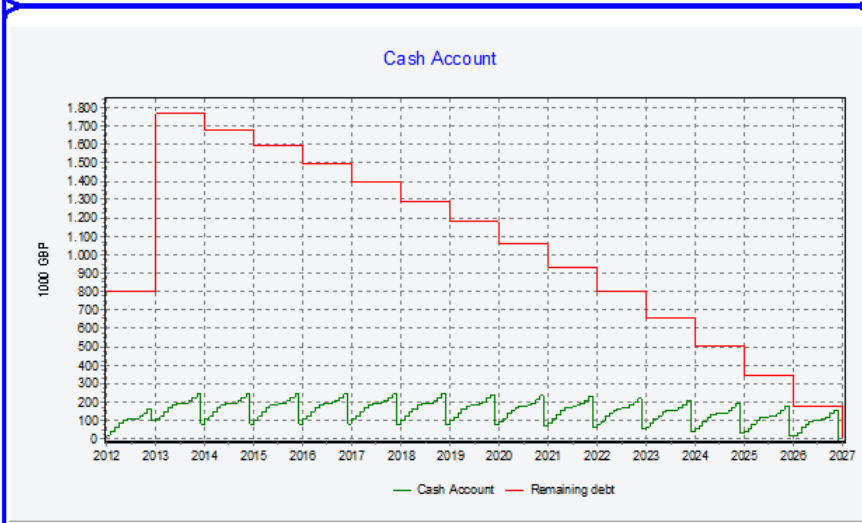
This example illustrates a cogeneration plant selling and buying its electricity on a fixed tariff market with income statements and balance sheets for a 15 years period.

Financial Key Figures**Investment Key Figures**

Net Present Value of		
Net cash from operation and investments	:	1.423.392 GBP
Tax payments	:	-441.389 GBP
Financial payments	:	223.014 GBP
All Payments	:	1.205.018 GBP
(at a nominal rate of: 6,0% p.a.)		

Figure 2.157: Financial key figures report

2.19.15 Income statement

The Income statement report for the energy company shows the result of the year for the company after depreciations and taxations.

Two CHPs on fixed tariffs, balance sheets and income statements
This example illustrates a cogeneration plant selling and buying its electricity on a fixed tariff market with income statements and balance sheets for a 15 years period.

Income Statement from januar 1, 2012 to december 31, 2012

(All amounts in 1000 GBP)

Revenues							
Sale of heat	:	12.000,0 MWh	at	0,025	=	300	
Sale of electricity	:						
Day	:	9.324,0 MWh	at	0,05	=	466	
Night	:	4.378,0 MWh	at	0,035	=	153	
Sale of electricity Total						619	919
Total Revenues							919
Operating Expenditures							
Fuel costs	:						
Natural gas	:	3.329.579,2 Nm3	at	0,0	=	666	
Climate change levy	:	3.329.579,2 Nm3	at	0,0	=	0	
Fuel costs Total						666	
Operation&Maint.	:						
Engine 1	:	9.620,0 MWh	at	0,005	=	48	
Engine 2	:	4.080,0 MWh	at	0,005	=	20	
Boilers	:	519,1 MWh	at	0,0	=	0	
Operation&Maint. Total						69	735
Total Operating Expenditures							735
Depreciations							
Investment						50	50
Total Depreciations							50
Operation Income							135
Financial Expenditures							
Loan, interest and fee's						48	
Interest on Cash Account						-3	
Total Financial Expenditures							45
Result Of The Year (before tax)							89
Tax payments							
Taxation						22	22
Total Tax payments							22
Result Of The Year							67

Figure 2.158: Income statement report

2.19.16 Income Statement, summary

The Income statement, summary report includes the balance sheet for all years in the planning period.

Two CHPs on fixed tariffs, balance sheets and income statements
This example illustrates a cogeneration plant selling and buying its electricity on a fixed tariff market with income statements and balance sheets for a 15 years period.

Income Statement, summary

(All amounts in 1000 GBP)

	2012	2013	2014	2015	2016	2017	2018	2019	2020	2021	2022	2023	2024	2025	2026
Revenues															
Sale of heat	300	299	298	299	300	298	298	299	300	299	298	298	300	298	299
Sale of electricity															
Day	466	466	463	463	464	466	466	466	471	463	466	464	463	463	463
Night	153	155	152	154	150	152	153	155	154	148	150	152	154	152	154
Sale of electricity Total	619	621	615	617	614	618	619	621	625	611	616	616	617	615	617
Total Revenues	919	919	913	916	914	916	917	919	925	910	912	914	917	913	916
Operating Expenditures															
Fuel costs															
Natural gas	666	666	665	667	664	662	664	666	669	661	661	662	663	665	667
Climate change levy	0	0	0	0	0	0	0	0	0	0	0	0	0	0	0
Fuel costs Total	666	666	665	667	664	662	664	666	669	661	661	662	663	665	667
Operation&Maint.															
Engine 1	48	43	43	43	43	43	43	43	43	43	43	43	43	43	43
Engine 2	20	20	21	21	20	20	20	21	20	20	20	20	21	21	21
Boilers	0	0	0	0	0	0	0	0	0	0	0	0	0	0	0
Operation&Maint. Total	68	63	64	64	63	63	63	64	63	63	63	63	64	64	64
Total Operating Expenditures	734	729	729	731	727	725	727	730	732	724	724	725	727	729	731
Depreciations															
Investment	50	100	100	100	100	100	100	100	100	100	100	100	100	100	100
Total Depreciations	50	100	100	100	100	100	100	100	100	100	100	100	100	100	100
Operation Income		135	86	86	86	86	84	84	86	86	84	84	86	86	86
Financial Expenditures															
Loan, interest and fee's	48	106	101	96	90	84	79	71	64	56	48	39	30	21	11
Interest on Cash Account	-3	-5	-5	-5	-5	-5	-5	-5	-5	-5	-4	-4	-4	-3	-3
Total Financial Expenditures	45	101	96	91	85	79	74	66	59	51	44	35	27	18	8
Result Of The Year (before tax)		89	-18	-11	-6	0	6	19	27	35	40	49	59	67	77
Tax payments															
Taxation	22	0	0	0	0	1	3	5	7	8	10	12	15	17	19
Total Tax payments	22	0	0	0	0	1	3	5	7	8	10	12	16	17	19
Result Of The Year		67	-18	-11	-6	0	4	14	20	27	30	37	44	50	58

energyPRO developed by EMD International A/S, Niels Jernes Vej 10, DK-9220 Aalborg Ø, Tlf: +45 96 35 44 44, Fax: +45 96 35 44 45, Homepage: www.emd.dk

Figure 2.159: Income statement report

2.19.17 Balance sheet

The last financial report is the balance sheets.

energyPRO4.2.182
Printed Page
30-10-2013 15:37:24 / 1
Licensed user:
EMD International A/S
Niels Jernes Vej 10
DK-9220 Aalborg Ø
+45 9835 4444

Two CHPs on fixed tariffs, balance sheets and income statements
This example illustrates a cogeneration plant selling and buying its electricity on a fixed tariff market with income statements and balance sheets for a 15 years period.

Balance Sheet as on december 31, 2012

(All amounts in 1000 GBP)

ASSETS	
Fixed assets	
Investment	950
Total Fixed assets	950
Total Cash Account	105
Total Other Current Assets	0
ASSETS	1.055
LIABILITIES	
Total Transferred Result	267
Short Term Liabilities	
Taxation	22
Total Short Term Liabilities	22
Long Term Liabilities	
Loan	766
Total Long Term Liabilities	766
LIABILITIES	1.055

Figure 2.160: Balance sheet report example

2.19.18 Balance sheet, summary

The balance sheet, summary report includes the balance sheet for all years in the planning period.

2.19.19 Catalogue of technical assumptions

This catalogue includes most of the technical data in the technical input data folders. The exception is that the time series are only represented by monthly min/max and average values. The structure of the catalogue follows the input data folder structure.

2.19.20 Catalogue of economic assumptions

This catalogue includes most of the financial data in the economy input data folders. The structure of the catalogue follows the input data folder structure. Formulas used for defining payments are placed in an appendix in the catalogue.

2.19.21 Operation Strategy Calculation

This report shows the calculation of the operation strategy in details. The report is invoked by clicking the Operations Strategy Calculation folder in the Reports tree view, shown in Figure 2.161.

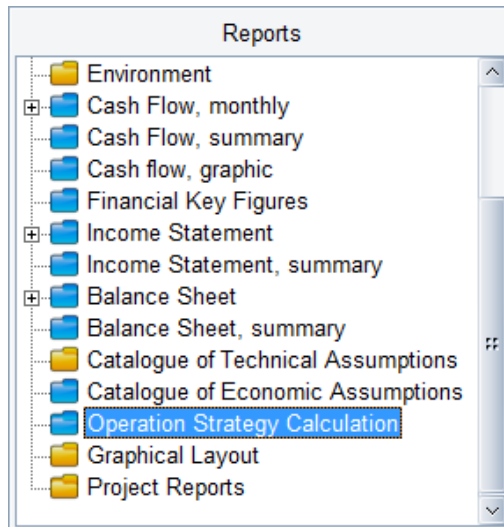

Figure 2.161: Selecting Operation Strategy Calculation

In the preview, choose the month to be shown (Figure 2.162).

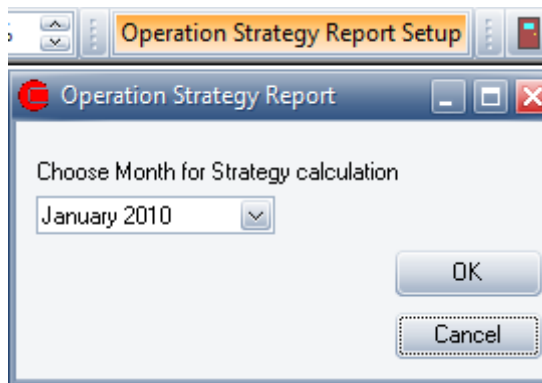

Figure 2.162: Selecting a month for the Report

Hereafter a report will appear. The report layout is depending on the selected operation strategy. Figure 2.163 show an example based on fixed tariffs, while Figure 2.164 show an example based on spot market optimization.

Fixed tariffs

The report starts with a main table containing the calculated Operation Strategy. The value in this table is identical with the values found in the “Operation Strategy” editing window.

Hereafter follows tables with detailed calculation results for each production unit. Each table contain the calculation of the net heat production costs in all tariff periods.

Note that payments that are identical for all production units in all tariff periods are excluded. This could for instance be a fixed payment not related to the energy conversion.

Two CHPs on fixed tariffs, balance sheets and income statements

This example illustrates a cogeneration plant selling and buying its electricity on a fixed tariff market with income statements and balance sheets for a 15 years period.

Operation Strategy Calculation (januar 2012)*Operation Strategy main tables***Net Heat Production cost**

[GBP/MWh-Heat]	Day	Night
Gas engine 1	3	17
Gas engine 2	3	17
Boilers	20	20

[All amounts in GBP/MWh-heat]

Gas engine 1

				Day	Night
Revenues					
Sale of heat	0,00	MWh at	25,00 =	0,00	0,00
Sale of electricity					
Day	-0,95	MWh at	50,00 =	-47,30	0,00
Night	-0,95	MWh at	35,00 =	0,00	-33,11
Sale of electricity Total				-47,30	-33,11
Total Revenues				-47,30	-33,11
Operating Expenditures					
Fuel costs					
Natural gas	226,50	Nm3 at	0,20 =	45,30	45,30
Climate change levy	0,00	Nm3 at	0,00 =	0,00	0,00
Fuel costs Total				45,30	45,30
Operation & Maint.					
Engine 1	0,95	MWh at	5,00 =	4,73	4,73
Engine 2	0,00	MWh at	5,00 =	0,00	0,00
Boilers	0,00	MWh at	0,50 =	0,00	0,00
Operation & Maint. Total				4,73	4,73
Total Operating Expenditures				50,03	50,03
Heat Production Costs				2,73	16,92

Figure 2.163: Operation strategy calculation on a fixed tariff example

Spot prices

The first page contains the graphic representation of the net heat production costs as function of the electricity spot prices (Figure 2.164, upper).

Hereafter follows one page per energy unit, where the net heat production costs are calculated for all production units (Figure 2.164 lower).

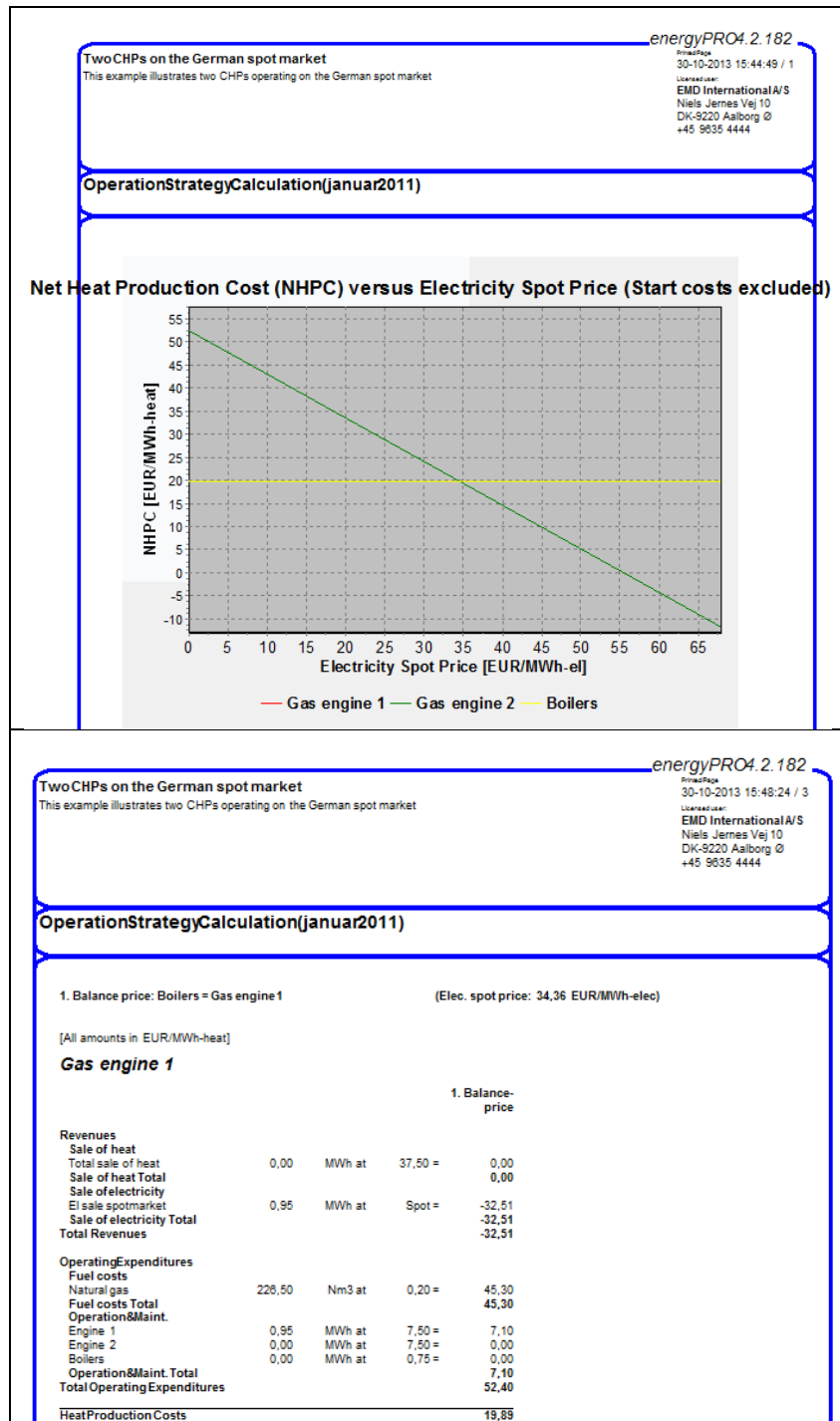

Figure 2.164: Operation strategy calculation a spot market example (Upper: Graphical presentation)

Tools

2.19.22 Introduction

At present two tools are available. The first is a tool for generating a time series of ambient temperatures and the second tool is a tool for copying energy calculation to the clipboard. The Tools menu is shown in Figure 2.165.

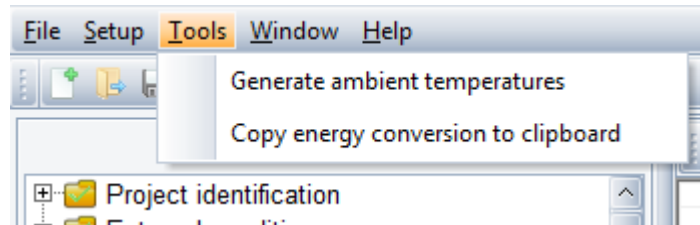

Figure 2.165: The Tools menu

2.19.23 Generate ambient temperatures

This tool is only expected to be used in situations, where time series of ambient temperatures are not available.

Generate ambient temperatures is a supplementary tool used for the creation of time series of ambient temperatures. It is a tool for distributing the monthly mean temperatures into a time series so they are useable for the project.

Ambient temperatures are e.g. used for distributing an annual heat demand to each day of the year.

In a project, you will normally use weather data for an average year.

You can use earlier saved sets of Ambient Temperatures as a starting point, when you are editing data. Right click on the window or use the load button. The imported data are shown in the window and can now be edited.

	Monthly mean	Standard deviation
January	-1,6	2,9
February	-1,1	3,3
March	2,6	2,1
April	6,6	2,4
May	10,6	1,7
June	15,7	1,8
July	16,4	2,0
August	16,6	2,2
September	13,7	1,5
October	9,2	2,5
November	5,0	2,6
December	1,6	3,8

Figure 2.166: Generate ambient temperatures

Remember to specify the symbol. It is important for identifying the time series.

If you want to save monthly data again you right click and select Save or use the save button. Specify an expressive name of the file.

Choose “Generate temperatures”-button to generate the time series to use in the project. In your project, you can choose to load the time series

2.19.24 Copy energy conversion to Clipboard

By choosing “Tools” and “Copy energy conversion to Clipboard” in the main menu, it is possible to copy data from the energy conversion results of a project to the clipboard, and then pasting the results into a spread sheet.

There are two categories of export, see the figure below. The first category “As time series” is structured in columns each containing a part of the energy conversion for a production unit or eventually a demand. Each row contains the energy conversion for a specific period. The second option is an output structured as the report “Energy conversion, monthly”.

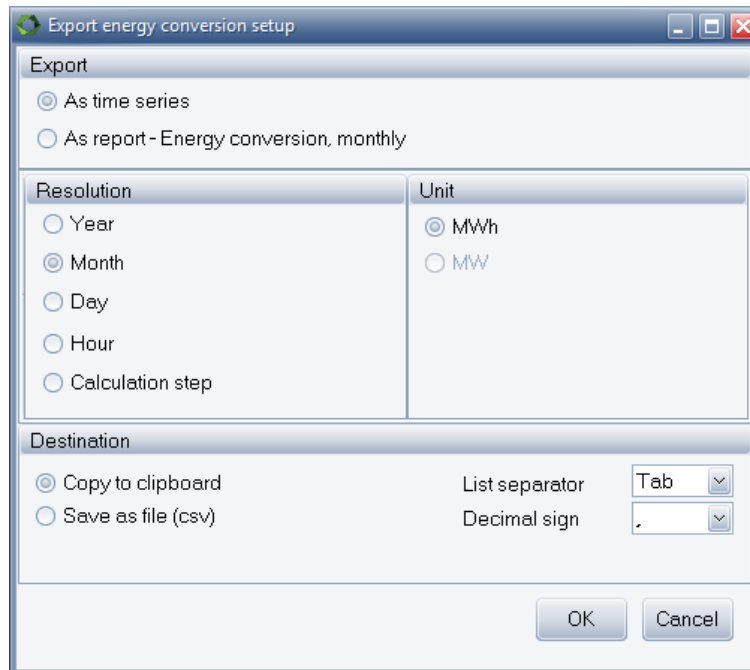

Figure 2.167: Export to Clipboard window

As time series

If “As time series” is chosen the available resolution options will depend on the actual used energyPRO module.

- DESIGN Monthly
- FINANCE Monthly/Yearly
- ACCOUNT Monthly/Yearly
- OPERATION Hourly/Daily

	A	B	C	D	E	F	G	H	I	J	K	L	M
1	Two CHPs on spot market												
2	Exported	30-12-2010	09:59										
3													
4		Gas engine 1	Gas engine 1	Gas engine 1	Gas engine 2	Gas engine 2	Gas engine 2	Boilers	Boilers	Total sale of heat	Net work loss	Delivered	
5		Fuel consum.	Elec. prod.	Heat prod.	Fuel consum.	Elec. prod.	Heat prod.	Fuel consum.	Heat prod.	Heat demand	Heat demand	electricity	
6	Date	[MWh]	[MWh]	[MWh]	[MWh]	[MWh]	[MWh]	[MWh]	[MWh]	[MWh]	[MWh]	[MWh]	[MWh]
7	01-01-2010	1.464,23	556	587,692	1.954,06	742	784,294	704,172	668,963	1.786,16	254,795	1.298,00	
8	01-02-2010	1.527,43	580	613,06	1.364,15	518	547,526	649,583	617,104	1.546,85	230,137	1.098,00	
9	01-03-2010	2.407,02	914	966,098	1.954,06	742	784,294	72,206	68,596	1.558,41	254,795	1.656,00	
10	01-04-2010	1.869,79	710	750,47	1.543,23	586	619,402	153,116	145,46	1.239,16	246,575	1.296,00	
11	01-05-2010	1.395,76	530	560,21	1.106,07	420	443,94	173,309	164,644	944,551	254,795	950	
12	01-06-2010	668,909	254	268,478	405,559	154	162,778	22,681	21,547	197,26	246,575	408	
13	01-07-2010	400,292	152	160,664	347,622	132	139,524	166,792	158,453	203,836	254,795	284	
14	01-08-2010	837,453	318	336,126	284,418	108	114,156	3,029	2,878	203,836	254,795	426	
15	01-09-2010	1.311,48	498	526,386	579,37	220	232,54	57,286	54,422	551,112	246,575	718	
16	01-10-2010	1.416,82	538	568,666	1.027,07	390	412,23	135,233	128,472	879,27	254,795	928	
17	01-11-2010	1.706,51	648	684,936	1.458,96	554	585,578	324,61	308,379	1.299,62	246,575	1.202,00	
18	01-12-2010	294,952	112	118,384	294,952	112	118,384	1.658,18	1.575,27	1.589,94	254,795	224	
19													

Figure 2.168: Example of data with monthly resolution pasted to the clipboard and then into Microsoft Excel

As Report “Energy Conversion, monthly”

If this option is chosen the data for, export to clipboard is structured as the report “Energy conversion, monthly”. If the FINANCE or ACCOUNTS module is chosen it is optional to choose between monthly and yearly data resolution. The option is not available if the OPERATION module is chosen.

- DESIGN Monthly
- FINANCE Monthly/Yearly
- ACCOUNT Monthly/Yearly
- OPERATION Not available

	A	B	C	D	E	F	G	H	I	J	K	L	M	N
1	Two CHPs on spot market													
2	Calculated period: 01-2010 - 12-2010													
3														
4		jan-10	feb-10	mar-10	apr-10	maj-10	jun-10	jul-10	aug-10	sep-10	okt-10	nov-10	dec-10	
5														
6	Heat demand [MWh]													
7		2.040,90	1.777,00	1.813,20	1.485,70	1.199,30	443,8	458,6	458,6	797,7	1.134,10	1.546,20	1.844,70	
8														
9	Electricity produced by energy units [MWh]													
10		1.298,00	1.098,00	1.656,00	1.296,00	950	408	284	426	718	928	1.202,00	224	
11	Peak prices	1.298,00	1.098,00	1.656,00	1.296,00	950	408	284	426	718	928	1.202,00	224	
12	I1	0	0	0	0	0	0	0	0	0	0	0	0	
13	I2	0	0	0	0	0	0	0	0	0	0	0	0	
14	Gas engine 1/Boilers	0	0	0	0	0	0	0	0	0	0	0	0	
15	I3	0	0	0	0	0	0	0	0	0	0	0	0	
16	I4	0	0	0	0	0	0	0	0	0	0	0	0	
17	0	0	0	0	0	0	0	0	0	0	0	0	0	
18														
19	Electricity consumed by energy units [MWh]													
20		0	0	0	0	0	0	0	0	0	0	0	0	
21	Peak prices	0	0	0	0	0	0	0	0	0	0	0	0	
22	I1	0	0	0	0	0	0	0	0	0	0	0	0	
23	I2	0	0	0	0	0	0	0	0	0	0	0	0	
24	Gas engine 1/Boilers	0	0	0	0	0	0	0	0	0	0	0	0	
25	I3	0	0	0	0	0	0	0	0	0	0	0	0	
26	I4	0	0	0	0	0	0	0	0	0	0	0	0	
27	0	0	0	0	0	0	0	0	0	0	0	0	0	
28														
29	Delivered electricity [MWh]													
30		1.298,00	1.098,00	1.656,00	1.296,00	950	408	284	426	718	928	1.202,00	224	
31	Peak prices	118	60	152	148	152	134	136	118	148	150	148	4	
32	I1	450	168	670	496	280	210	8	286	470	538	638	112	
33	I2	416	624	442	480	48	64	34	22	78	200	372	100	
34	Gas engine 1/Boilers	314	246	392	172	470	0	106	0	22	36	42	8	
35	I3	0	0	0	0	0	0	0	0	0	4	2	0	
36	I4	0	0	0	0	0	0	0	0	0	0	0	0	
37	0	0	0	0	0	0	0	0	0	0	0	0	0	
38	Peak [MW]	4	4	4	4	4	4	4	4	4	4	4	4	
39														

Figure 2.169: Example of data organised as report “Energy conversion, monthly” pasted to a Microsoft Excel spreadsheet via the clipboard.

3 Method of calculation in energyPRO

3.1 Method of energy calculation in energyPRO

This chapter describes how energyPRO calculates optimal fuel consumption, heat production, electricity production, electricity consumption and cooling production from production units situated in local energy plants.

3.1.1 The optimisation problem

energyPRO is a powerful tool in which you can model complicated energy systems, consisting of an unlimited number of demands and energy units.

The model of the energy system and the applied operation strategy (user defined or auto calculated) determines the productions and consumptions of the production units. energyPRO helps making the productions optimal, for instance by easy accessible ways of changing the modelled energy system and operation strategy. The performance of sensitivity analyses is easily done by the use of energyPRO.

It is important to keep in mind that optimising a local energy plant is often a complex task.

Normally, the demand for electricity is high in the morning and in the afternoon, lower during the rest of the day and lowest during night time, weekends and holidays. Reflecting on this, the prices paid for the produced or consumed electricity may vary significantly with the time of the day. On the other hand, a heat demand is normally low during summers and many times higher during winters, and a cooling demand will normally be higher in the summer periods and lower in the winter periods.

A thermal store or cooling storage is one way of solving this mismatch between the need of electricity and heat/cooling. Another way to add flexibility is to add heat blow-off capacity allowing electricity producing energy units to be used more flexible.

Another complexity is that fuel, e.g. biogas, can be restricted in amount and eventually stored in a fuel-storage. A CHP unit might for instance be

able to use two types of fuel e.g. biogas and natural gas, where the biogas is restricted in amount and can be stored in a biogas-storage and the heat can be stored in a thermal store. An energy unit might be operated with or without an economizer.

Another complexity can be that the electricity production is restricted to a certain demand for electricity e.g. the electricity demand in a town. Furthermore, electricity consuming heat pumps increase the complexity of energy system calculations.

energyPRO makes it possible to analyse optimal solutions, taking into account all the above-mentioned factors.



Figure 3.1: In this figure heat productions and thermal store in a week in May.

In the shown example it is assumed, that the demand for electricity is highest in the daytime (high tariff). During night time, in the weekends and on official holidays the demand is reduced even further (low tariff) - The price structure for the electricity production reflects this variation, and hence the priority number (Net Production Cost) in the top graph are lower for the CHPs in the day time compared with the night time and weekend.

The heating demand is low during the summer and much higher during the winter. A thermal store is used to solve the temporal displacement between the demands for electricity and the demand for heating.

3.1.2 Time series is a fundamental object in energyPRO

Project information has to be available and the energy system has to be modelled, before energyPRO starts calculating optimal energy productions. Directly and indirectly time series are playing a core object

in all energyPRO models. This could be weather data, demands, electricity prices, results etc.

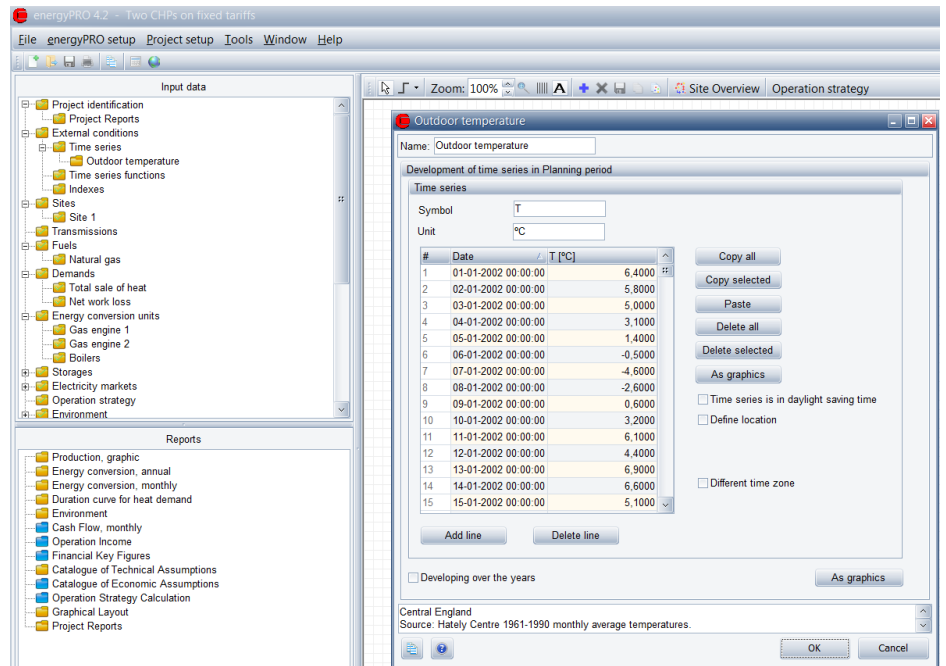

Figure 3.2: A time series consists of a symbol, a unit and a set of points consisting of Date, Time and Values

When you have made a new time series, this time series is available both to model the variation of demands, to influence the power curves of production units and to describe electricity prices on the spot market.

During an energyPRO calculation the calculation period is split in to fixed calculation steps where everything is constant. The size of this step is controlled in the Project Identification. If your time series do not match the specified calculation step, energyPRO will calculate mean values or closest values for a given calculation step.

energyPRO automatically extends your time series

If you have described in an energyPRO-model, that demands or production units depends on some external condition (e.g. ambient temperature), energyPRO needs to know for the complete planning period, the values of this external condition. The hard way of doing this is to create your own time series for the complete period. This will normally be inconvenient and unnecessary.

Often you have access to information for a period of one year, which you want to extend to the whole planning period - this will automatically be done within the energyPRO calculation.

The extension is based on the following principles.

Within one specific year: A time series is well defined between the first time (start time) and the last time (end time). Outside start time and end time, the value is identical with the value at the end time.

From one year to another year. There is two options for extension of time series.

- a) The extension is weekly based.
- b) The extension is date based

Option a). This means that Monday in week 2 will adopt the values from Monday in week 2 in the nearest year, etc.

energyPRO follows the ISO week date system, where each week begins on a Monday.

There are special conditions around New Year. If a given weekday in week 1 in the planning period is not present in the time series, the value for the weekday in week 2 is used. If a given weekday in week 52 in the planning period is not present in the time series, the value for the weekday in week 1 is used. If Monday to Tuesday in week 53 in the planning period is not present in the time series, the value for the weekday in week 52 is used. Finally, if Friday to Sunday in week 53 in the planning period is not present in the time series, the value for the weekday in week 1 is used.

The main reason for making the time series weekly based is that some variation described in time series often varies systematically within a week. E.g. electricity demands in weekdays are often significantly different from electricity demands in weekends.

Option b). This means that e.g. February 2nd 2014 is equal to February 2nd 2015.

Demands are also time series

In energyPRO, it is not obvious, that demands are time series, identical to time series for external conditions. That is because you get a lot of help to model the variation of a demand.

But if you convert this demand to time series it becomes obvious, that a time series for a demand is exactly identical to time series for external conditions, also being available by formula expressions to influence the power of production units.

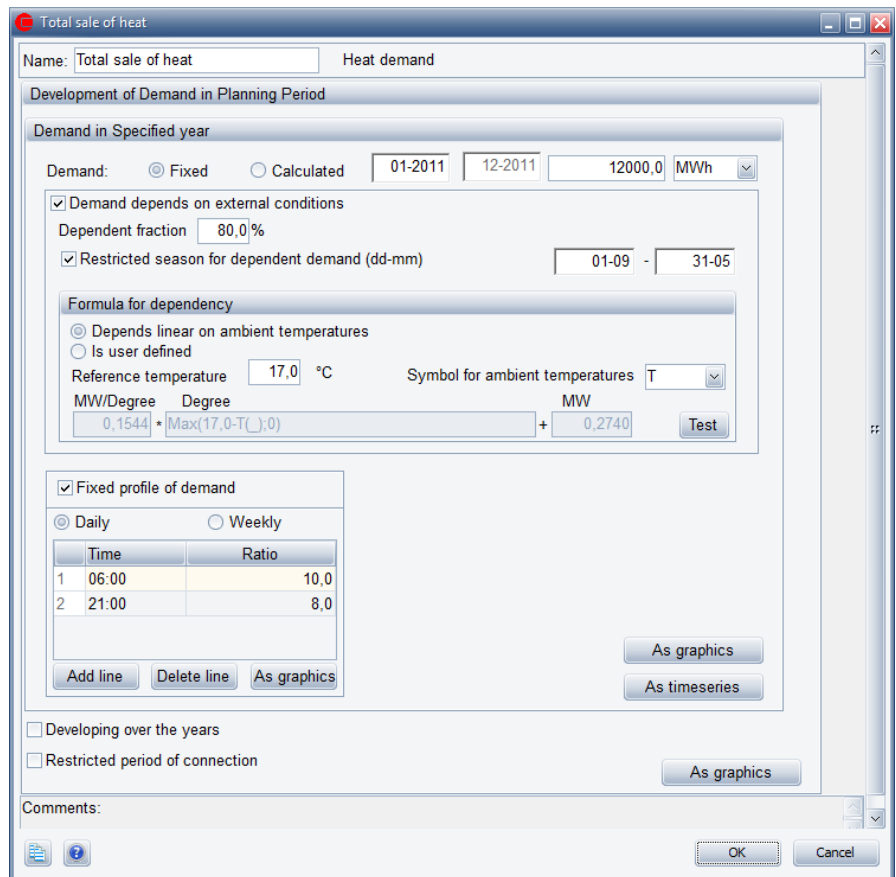

Figure 3.3: Time series for demands are identical to time series for external conditions.

Modelling variation of demands with use of a fixed profile of demand

It is possible to state that a demand has to follow a fixed profile of demand. See the bottom table in the editing window on Figure 3.3.

If a fixed profile of demand is chosen, daily or weekly, then the demand time series created so far will be modified. The main principle is that the demand on daily (or weekly) basis will remain unchanged, but the distribution within the 24 hours a day (or week) will be redistributed so it follows the stated fixed profile of demand.

3.1.3 Splitting up the planning period (fixed tariffs)

Splitting into time periods

The period of optimisation is divided into time periods, where everything is constant, e.g. ambient temperature, solar radiation, priorities, heat demand, electricity demand, cooling demand, production capacities, fuel imports etc.

Group time periods for optimization

In “Electricity markets”, the time periods can be divided into groups. Such a division is often convenient if electricity prices vary systematically. Each group is labelled by a “Priority name”. In the figure below, there are three priority names. “Peak Load”, “High Load” and

“Low Load”. The grouping of the periods is specified by mean of the lower table. The example will divide a year into hundreds of time periods during a year.

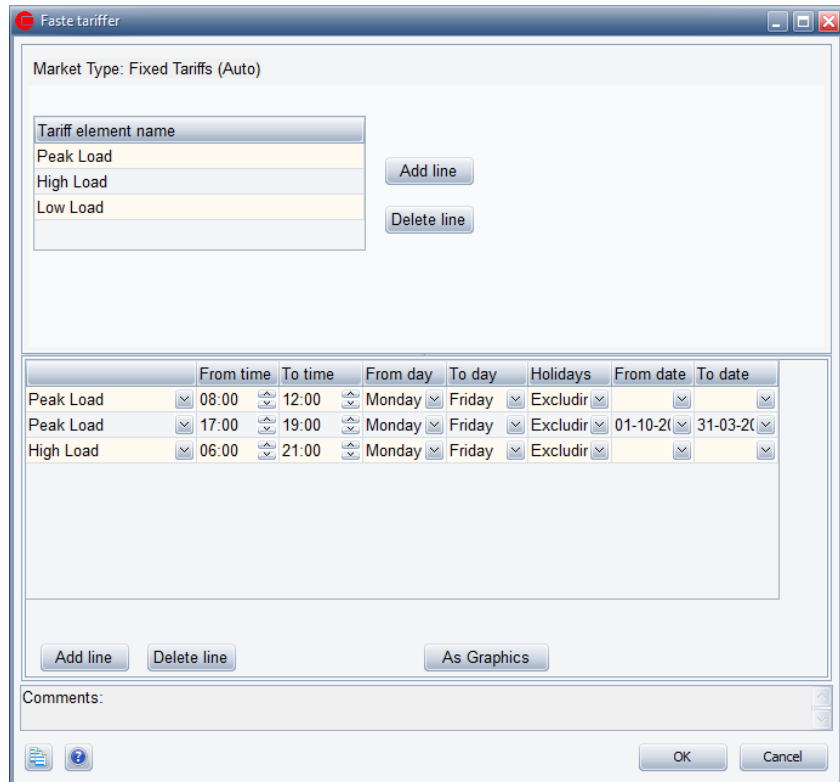

Figure 3.4: An example of how to group thousands of time periods into three groups, Peak load, High load and Low load.

This information is used when the operation strategy is designed.

3.1.4 Energy conversion units

There are two sorts of energy conversion units. The options are a production unit and a heat blow-off unit

Production unit

Regarding the energy conversion calculations the production units contains the definition of the power curves and eventually some time restrictions.

A production unit is described by a set of power curves, which varies for different types of production units. The optional curves are:

- Fuel consumption
- Fuel production
- Heat production
- Process heat production
- Heat consumption
- Process heat consumption
- Electricity production

- Electricity consumption
- Cooling production
- Fuel production

Gas engine 1

Name: Gas engine 1

Production unit type: CHP Non availability periods

Fuel: Natural gas

Powerunit: kW

Start Time	End Time	Every Year
09-01-2012	17-01-2012	<input checked="" type="checkbox"/>
01-02-2012	09-02-2012	<input checked="" type="checkbox"/>

Min. Operation time (Hours): 2

Add line Delete line Load Save

Power curves

Operation	Fuel	Heat	Elec. power
Performance	kW	kW	kW
Linear	5267,0	2114,0	2000,0

Add line Delete line Enable formulas in power curve

Operation dependent on other unit

Figure 3.5: Example of description of a production unit, here a standard CHP unit with three power curves: Fuel (consumption), Heat (production) and electricity (production)

The power curves are described by one or more lines which together define a set of continuous curves. All numbers in a specific line has to be less or equal to the equivalent value in the line above. The upper line states maximum load, while the lower curve states the minimum load.

The power curves might vary from one time period to the next (the power curves might be a function of external conditions, for instance the return temperature of district heating water or the ambient temperature).

If the power curves are described by only one line it implies that there automatically has been assumed added an extra line containing only zeroes, describing the minimum load (if part load is allowed in the operation strategy).

It is also possible to state that the production on a specified production unit depends on other units which can be done either by checking "Operations dependent on other unit" or checking "Enable formulas in power curves" and then using the PaP-functions in the power curves.

Heat rejection unit

A heat rejection unit is described by a constant heat rejection capacity all year.

In the Operation strategy you have to state, which production units have access to the heat rejection unit.

3.1.5 Thermal storage and cold storage

A thermal storage and cold storage is in each time period defined by a maximum content measured in MWh of either heating or cooling. In the Operation strategy, you have to state, which production units have access to these storages.

3.1.6 The Operation strategy (example with Fixed tariffs – User defined)

The operation strategy consists of two main tabs (three or four if the model contains both a heating demand and a cooling demand and/or fuel producing units). These are “Heat (or cooling, or Fuel) Production Strategy” (or “Net Heat/Cooling Production Cost” when automatic operation strategy are chosen) and “Energy Unit Setup”.

These main tabs are shown in Figure 3.6 with only a heating demand using Fixed tariff and in Figure 3.7 with a heat rejection unit.

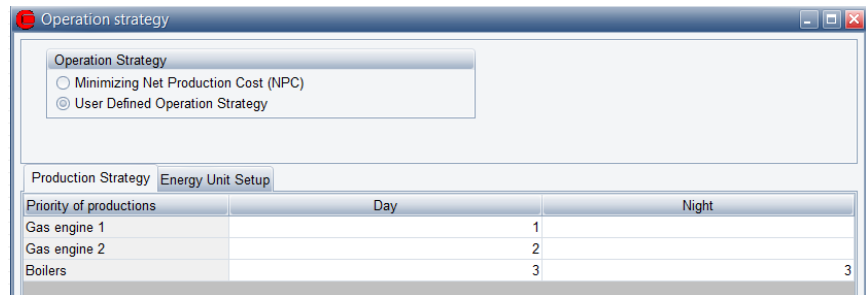

Figure 3.6: An example where the Operation strategy is used for controlling the priority of production between two engines and a boiler.

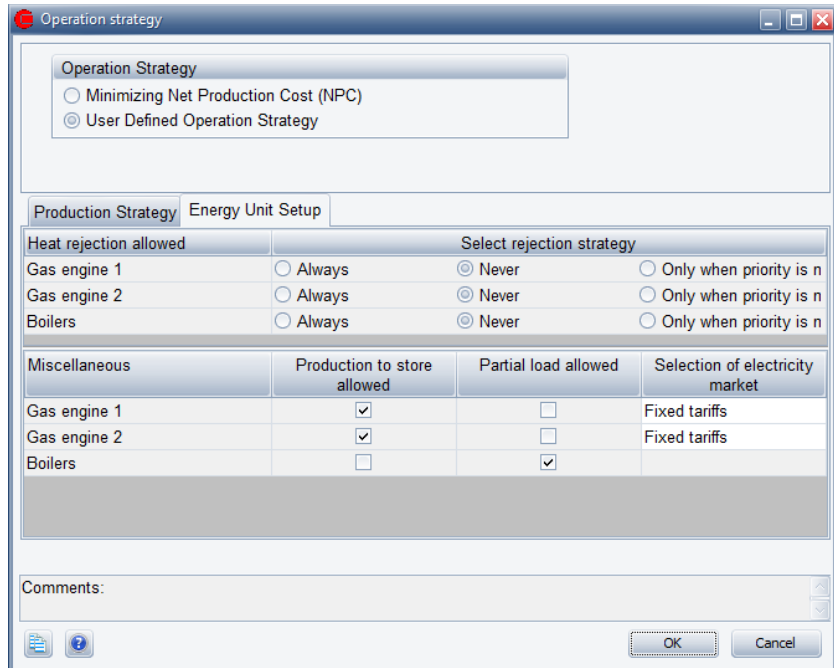

Figure 3.7: “Energy Unit Setup” tab for the same example as in Figure 3.6

Priorities of production section

In the “Priority of productions” table in the “Production Strategy” tab you find a matrix consisting of Priority periods specified in the “Electricity markets” editing window in the column dimension and the defined production units in the row dimension.

In Figure 3.6 it is seen that the production from the two gas engines are prioritised in the rank “Day” indicated by increasing numbers. Furthermore it is seen that, Gas engine 1 is prioritised before Gas engine 2, within the respective period of priority. In the example, the boilers are always prioritised after the engines, and are only allowed to produce if the engines are not able to produce all the heat needed in the “Day” tariff.

Given the matrix in Figure 3.6, energyPRO now first calculates Gas engine 1 in Day and then Gas engine 2 in Day. Finally Existing boilers take the residual productions.

Note that if no number is attached to an element in Priority of Productions table the production unit will not operate in that specific priority period.

Heat rejection allowed

In the “Heat rejection allowed” table in the “Energy Unit Setup” tab you can define which energy conversion units are allowed to reject heat, if the heat cannot be utilized or stored. This table is only shown if a “Heat rejection” has been added.

Miscellaneous

In this section of the “Energy Unit Setup” tab is specified another matrix, horizontally consisting of some options and vertically of the defined production units. The options are:

- Production to store allowed (only if a thermal or cold store is defined)
- Production transmitted to other sites (only if there are more sites in the project)
- Partial load allowed
- Selection of electricity market

3.1.7 Calculating a time period under restrictions

A usual method of calculating energy productions would be making a chronological hour for hour calculation, taking into account, that e.g. producing in the night might fill the thermal store too early, prohibiting more attractive productions to be placed the day after in the morning.

To secure productions in the most favourable periods, energyPRO does it the opposite way. It starts producing in the most favourable periods, not doing it chronologically. This has the consequence that each new

production has to be carefully checked to make sure it does not disturb already planned productions, before being accepted.

The year is divided into a fixed number of time periods (depending on the calculation step), which are all tested for possible productions.

In this section it is described, how optimal production from a production unit is planned in one time period and it is described how a sufficient derating (reduced load) is determined.

As a starting point, an attempt is made to keep the production unit running by sufficient derating the load of the production unit in the whole time period in order to reduce the number of starts.

The ability to derate the load might be limited for two reasons. The first reason being that if partial load is not allowed (miscellaneous section in Operation strategy). The second reason is the possibility that a minimum load appears on the power curve(s).

Taking into account dependency on another production unit

It is possible to state, that production of a unit is only allowed, if no production is planned on another production unit. If there in a certain time period is already planned production on the specified unit, no production will be made on the second unit.

Contrary to this, it is possible to state, that production is only allowed, if production on a second unit is already planned.

If there in a certain time period is planned production on a second specified production unit, the load of the considered unit is limited to the load on the second unit.

Production may be limited to electricity demand

In the Operation strategy it is possible to state that the project should run in Island Operation mode with no exchange to the electricity market. In this case electricity production must be limited to the electricity demands. The allowed electricity production is calculated by taking the electricity demand then adding the electricity consumption from higher prioritised production units and finally subtracting the electricity production from higher prioritised production units. The considered production unit is derated, so that it does not exceed the allowed electricity production.

Limitation in heat and cooling production

It is controlled, that the derating of a production unit is sufficient, so that already planned future productions are not disturbed. That is to say that the thermal or cooling storages are not overfilled in the future due to the heat or cooling production in the considered time period.

If production to thermal or cooling storage is not allowed for a specified unit in the Operation strategy, the heat or cooling production from that production unit must not change the planned use of the thermal or cooling store.

If you in the Operation strategy has chosen, that the production unit has no access to a heat rejection unit (cooling tower), the heat production from the production unit must not change the planned use of the heat rejection unit in the future.

Limitation in fuel consumption

It is controlled, that the derating of a production unit is sufficient, so that already planned future productions are not disturbed. That is to say that there is sufficient fuel in the fuel storage in the future for already planned productions.

If it is possible to reduce load, so that the above-mentioned limitations are met, a new planned production has been found and accepted.

3.1.8 Planning of new productions follow Operation strategy

The Operation strategy is where you choose the superior priority of productions. Priority numbers states the order of productions. The units are calculated by increasing numbers. I.e. the unit with the lowest number is calculated first. All possible production on a unit is fully obtained before production with the next unit (with the next priority number) is examined and calculated.

Reducing number of starts

Given the above priority information there will be a lot of time periods with the same priority and these could simply be started chronologically which would give a "correct" result with regards to energy conversion. However, we have experienced that the chronological approach produces too many starts which is not desirable since most production units will have some kind of start cost.

Reducing starts by giving priority to expansion before new starts

If at a given time during an optimization there is both the possibility to expand an already started block and start a new block with the same priority we will always select the expansion before starting a new block. This is of course only the case if the expansion can be done under all the restrictions mentioned in 3.1.7.

Reducing starts by adding start costs

In the payment lines for a production unit it is possible to add a start cost for each time the unit is started. If such a start cost is defined it will influence the priority of that unit during the optimization. The start cost is simply added to the priority of that unit and thereby making it even more undesirable to start that unit compared to expanding the unit in already started blocks.

As an example please consider the scenario during an optimization where we can either expand a block at priority 56 or start a new block at priority 45 (without start cost added). Without start costs we would

simply start the new block and thereby might generate unnecessary starts. If we then have a start cost of 20, the new priority for starting up would be $45+20$ and hence we now prefer to expand at priority 56 instead.

Reducing starts by merging already started blocks

Now that start costs can prevent us from starting new blocks we can also consider the other scenario where we want to merge two blocks in order to remove one of the starts. During the optimization we will continuously look at whether two blocks can be merged to remove a start. The time periods in between the blocks might not have a good enough priority from the operation strategy to be started, but given the fact that we will remove a start we now reduce their priorities according to the removed start cost.

Reducing starts by looking for empty heat or cold storage

Even with the start cost considerations there will still be situations where we see too many starts because a production unit keeps starting up every time it “sees” that there is room for it in the heat or cold storage. To prevent these starts we will always delay a start until the heat or cold storage is empty as long as the priority is the same in the next calculation step. This ensures that when the unit is started it can keep running for as long as possible (it could still be restricted by other things).

Reducing starts by looking for full fuel storage

In the same way a unit could keep starting for a short while whenever there is enough for it to run in the fuel storage. So in this case we will delay the start until the fuel storage is full (again given the next calculation step has the same priority). This gives the unit the longest start block without being restricted by the fuel input.

3.1.9 An example of planning optimal productions in energyPRO

The aim of this section is to give an understanding of how productions are calculated in energyPRO and thus give an idea on how to create optimal productions. This introduction is based on a week in April. First, the final planned production for the week will be presented. Hereafter it is shown how the production is constructed by adding priority numbers in the Operation strategy one by one.

The principle described in this section is the same regardless of the selected electricity market and whether the Operation strategy is user defined or auto calculated.

Planned production

In Figure 3.8 is shown a graphic representation of an example with three energy conversion units. These units are two gas engines and a boiler. A

thermal store has furthermore been added. The example has an electricity tariff with three levels attached.



Figure 3.8: Graphic representation of energy production, a week in April-May

We see that the CHP shuts down in the nights, because productions in low load have low priority. Hereto comes an active use of the thermal store.

Production Strategy		Energy Unit Setup		
Priority of productions	Peak load	High load	Low load	
Gas engine 1	1	3	5	
Gas engine 2	2	4	6	
Boilers	7	7	7	

Production Strategy		Energy Unit Setup		
Miscellaneous	Production to store allowed	Partial load allowed	Selection of electricity market	
Gas engine 1	<input checked="" type="checkbox"/>	<input type="checkbox"/>	Fixed tariffs	
Gas engine 2	<input checked="" type="checkbox"/>	<input type="checkbox"/>	Fixed tariffs	
Boilers	<input type="checkbox"/>	<input checked="" type="checkbox"/>		

Figure 3.9: Operation strategy for energy production

Priority of productions. We see that the engines are always prioritised before boilers.

For the engines, we see that production in peak load hours is always prioritised before high load, which again are prioritised before low load. Finally, that Gas engine 1 is prioritised before gas engine 2 within the same priority of production (for instance peak load).

Miscellaneous: The two engines are allowed to produce to the storage, the boiler is not. Partial load are only allowed on the boilers.

The Periods of priority in the considered week are shown in Figure 3.10. As seen, there are three levels. The lower level in the graph is Low load, the middle level is High load and the highest level is Peak load. The weekdays Monday to Friday is low load from 0.00 to 6.00 am, high load until 8.00, then peak load until 12.00, then high load until 20.00 and finally low load until 00.00. Saturday and Sunday is low load all day.



Figure 3.10: Electricity Market – Tariffs shown as graphics

Planning production step by step (priority by priority)

In the following, the above shown example is elaborated by adding priority numbers one by one and the result after adding this will be presented graphically and briefly discussed.

Adding Priority 1 - Gas engine 1 in peak load

Production Strategy		Energy Unit Setup		
Priority of productions	Peak load	High load	Low load	
Gas engine 1	1			
Gas engine 2				
Boilers				

Figure 3.11: Priority 1 chosen

Figure 3.12 shows that the heat production from “Gas engine 1” in the five peak load periods, in this week, is well below the demand curve. In other words, the productions are filled in without any sort of restriction or use of the thermal storage.

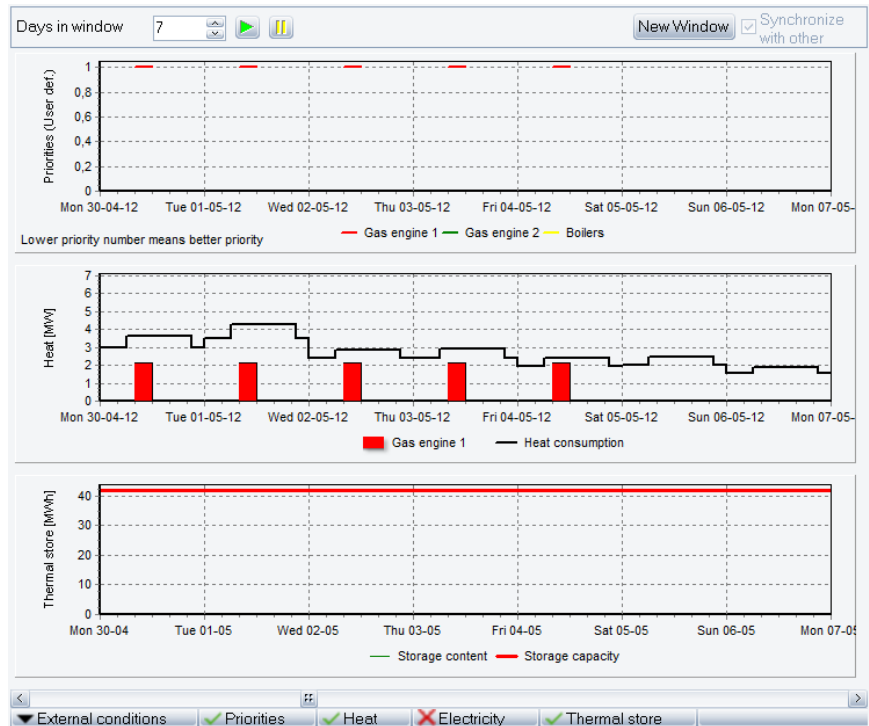

Figure 3.12: Graphic representation of energy production priority 1.

Adding 2 priority: Gas engine 2 in peak load

Production Strategy		Energy Unit Setup		
Priority of productions	Peak load	High load	Low load	
Gas engine 1	1			
Gas engine 2	2			
Boilers				

Figure 3.13: Gas engine 2 in peak load. Priority 2 included

Now the heat production from the two gas engines is not always below the heat demand curve. The graphic representation of the content in the thermal store shows that the energy plant is starting to utilize the store in order to secure the production in peak load hours. The storage is here emptied well before the next peak load period occurs.



Figure 3.14: Energy production graphic. Priority 2 included

Adding priority 3: Gas engine 1 in high load hours

Production Strategy		Energy Unit Setup		
Priority of productions	Peak load	High load	Low load	
Gas engine 1		1	3	
Gas engine 2		2		
Boilers				

Figure 3.15: Gas engine 1 in high load, Priority 3 included

After having included the third priority, Gas engine 1 in high load hours, the production is still not restricted. The use of the thermal store is increasing.



Figure 3.16: Energy production graphic. Priority 3 included

Adding priority 4: Gas engine 2 in high load

Production Strategy		Energy Unit Setup		
Priority of productions	Peak load	High load	Low load	
Gas engine 1	1	3		
Gas engine 2	2	4		
Boilers				

Figure 3.17: Gas engine 2 in high load. Priority 4

Including the fourth priority “Gas engine 2” in high load hours, there are room for the production without restrictions. We can now conclude that in the actual week it is possible to run the engines in as well all peak load hours as all high load hours and still utilize the produced heat. This is achieved by using the thermal store.



Figure 3.18: Energy production graphic. Priority 4 included

Adding Priority 5: Gas engine 1 in low load

Production Strategy		Energy Unit Setup		
Priority of productions	Peak load	High load	Low load	
Gas engine 1	1	3	5	
Gas engine 2	2	4		
Boilers				

Figure 3.19: Gas engine 1 in low load. Priority 5

After having included priority 5, “Gas engine 1” in low load hours, it is no longer possible to run the energy plant without restrictions. As seen there are now two periods (in the low load hours), where there are no production on the engines. The use of the thermal store is still increasing.

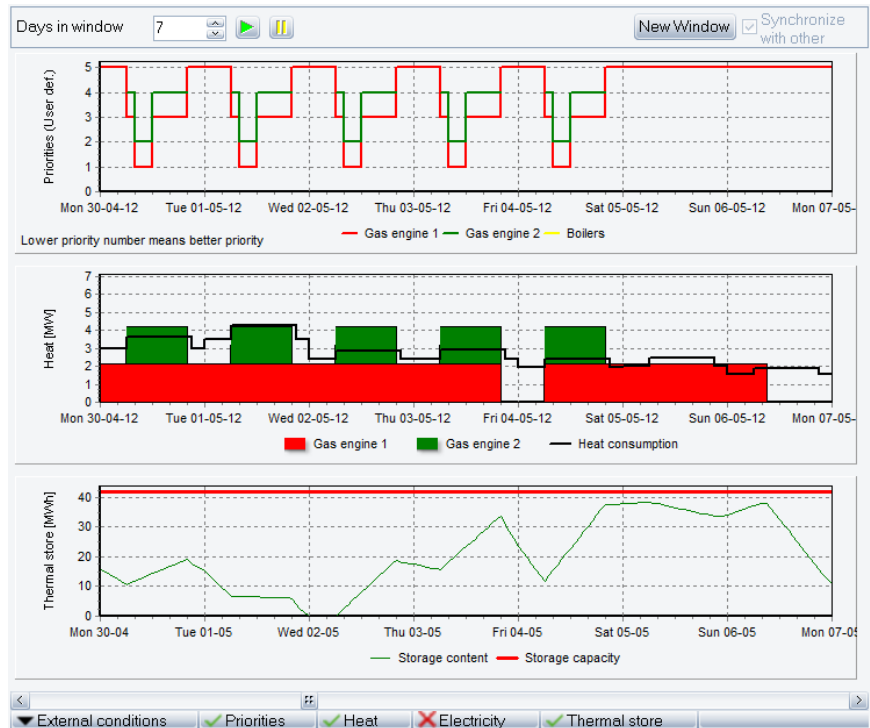

Figure 3.20: Energy production graphic. Priority 5 included

Adding priority 6: Gas engine 2 in low load

Production Strategy		Energy Unit Setup		
Priority of productions	Peak load	High load	Low load	
Gas engine 1	1	3	5	
Gas engine 2	2	4	6	
Boilers				

Figure 3.21: Gas engine 2 in low load. Priority 6 included

The use of “Gas engine 2” in low load hours has priority 6. The result of enabling that priority is that production is established in the first two low load periods, while there are room for the production the two first, but not in the last three. Looking at the development of the content in the thermal store it can be seen that the content builds up in the well-paid peak and high load hours, so it can be drained in the “poorly”-paid low load hours.

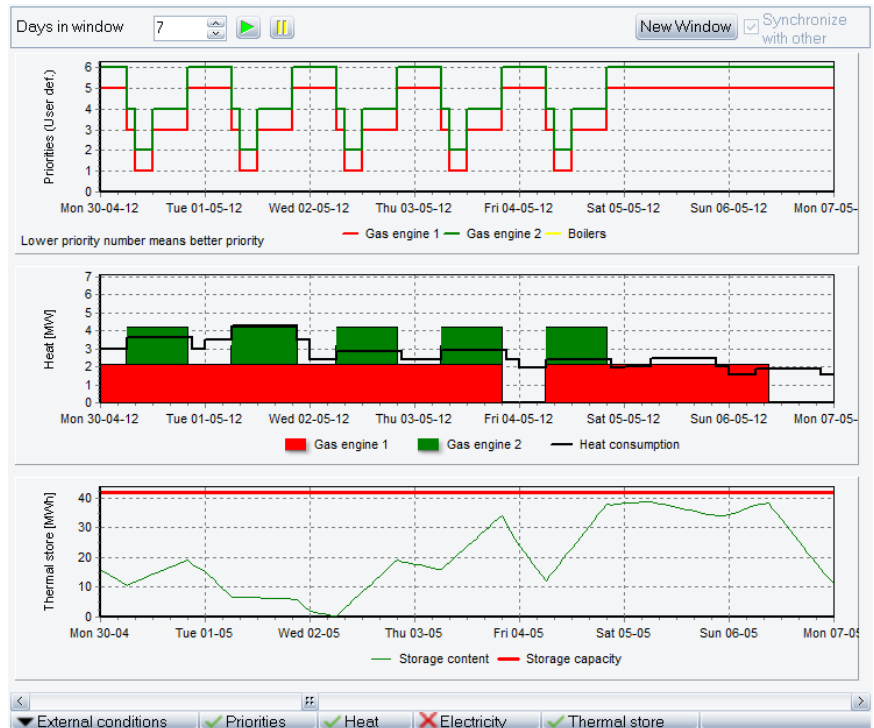

Figure 3.22: Energy production graphic, priority 6 included

The inclusion of priority 7 for the boilers in all periods will not result in any production changes in this week because all needed production can be established on the two engines. With the chosen Operation strategy, the boilers will only be active during wintertime with high heat demands, or when engines are out for revision.

3.2 Method of economy calculation in energyPRO

In this chapter is described, how energyPRO calculates the economy in a project.

It is important to remember, that economy in energyPRO is basically monthly based, and that it is possible for you to model exactly the size of each monthly payment in all months of the Planning period, e.g. 30 years (equal to 360 month).

energyPRO 4.2.182
05-11-2013 08:44:18 / 1
Energy use:
EMO International A/S
Niels Jernes Vej 10
DK-9220 Aalborg Ø
+45 9635 4444

Two CHPs on fixed tariffs, balance sheets and income statements
This example illustrates a cogeneration plant selling and buying its electricity on a fixed tariff market with income statements and balance sheets for a 15-year period.

Cash Flow, monthly

Calculated Period: 01-2012 - 12-2012
(All amounts in GBP)

	Total	Jan	Feb	Mar	Apr	May	Jun	Jul	Aug	Sep	Oct	Nov	Dec
Revenues													
Sale of heat	300 000	43 865	40 459	37 415	29 891	22 456	4 918	5 082	5 082	14 253	23 265	33 217	40 097
Sale of electricity													
Day	466 200	45 600	36 000	52 800	46 200	44 400	20 900	21 400	22 000	29 600	44 700	52 200	50 400
Night	153 160	32 620	21 910	21 350	14 980	6 860	0	140	0	5 880	8 260	16 100	25 060
Sale of electricity Total	619 360	78 220	57 910	74 150	61 180	51 260	20 900	21 540	22 000	35 480	52 960	68 300	75 460
Total Revenues	919 360	122 085	98 369	111 565	91 071	73 716	25 818	26 622	27 082	49 733	76 225	101 517	115 557
Operating Expenditures													
Fuel costs													
Natural gas	665 916	90 185	72 346	79 830	64 757	51 913	20 029	20 702	21 068	36 390	54 116	72 014	82 565
Climate change levy	0	0	0	0	0	0	0	0	0	0	0	0	0
Fuel costs Total	665 916	90 185	72 346	79 830	64 757	51 913	20 029	20 702	21 068	36 390	54 116	72 014	82 565
Operation&Maint.													
Engine 1	48 100	4 980	4 640	5 690	4 660	3 740	2 050	2 160	2 200	3 240	4 940	5 860	5 860
Engine 2	20 400	4 240	2 090	2 640	2 100	1 680	40	0	0	560	1 710	2 580	2 760
Boilers	260	49	206	2	1	0	0	0	0	0	0	0	0
Operation&Maint. Total	68 760	9 269	6 936	8 332	6 761	5 420	2 090	2 160	2 200	3 800	5 650	7 520	8 620
Total Operating Expenditures	734 675	99 455	79 282	88 162	71 517	57 333	22 120	22 862	23 268	40 190	59 766	79 534	91 185
Net Cash from Operation	184 685	22 630	19 086	23 403	19 554	16 383	3 698	3 760	3 814	9 543	16 459	21 983	24 372
Investments													
Investment	1 000 000	1 000 000	0	0	0	0	0	0	0	0	0	0	0
Total Investments	1 000 000	1 000 000	0	0	0	0	0	0	0	0	0	0	0
Cash From Long Term Financing													
Loan	800 000	800 000	0	0	0	0	0	0	0	0	0	0	0
Total Cash From Long Term ...	800 000	800 000	0	0	0	0	0	0	0	0	0	0	0

Figure 3.23: An example of monthly payments, all being defined by you, to be seen in the report Cash flow, Monthly.

3.2.1 energyPRO calculates nominal payments

Please notice that the monthly payments defined in energyPRO is your best guess about the payments taking place in all months in the Planning period. It is not payments converted to the value of the payment in a specific year (it is not fixed prices).

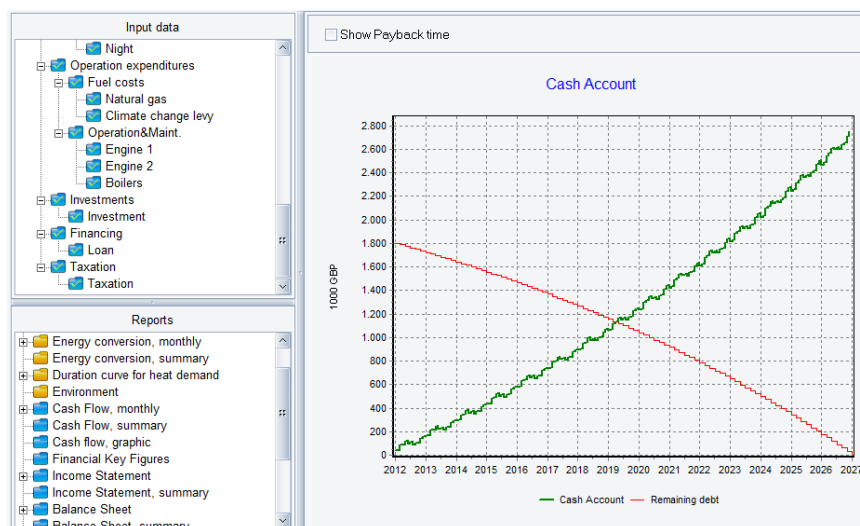

Figure 3.24: You are on a monthly basis able to follow how payments in and out of cash account are accumulated.

3.2.2 Net present value calculation

Nominal discount rate is given on a yearly basis, e.g. 7,0 % per year. But in the Net present value calculation every monthly payment are brought back to Present (start of the Planning period) on a monthly basis. Therefore the yearly discount factor (e.g. 1,07) is converted to a monthly discount factor (e.g. the yearly 1,07 is converted to the monthly 1,005654), being used for bringing back payments to Present.

You are able to see the Net present value of the payments only belonging to the Financing, as a sub balance.

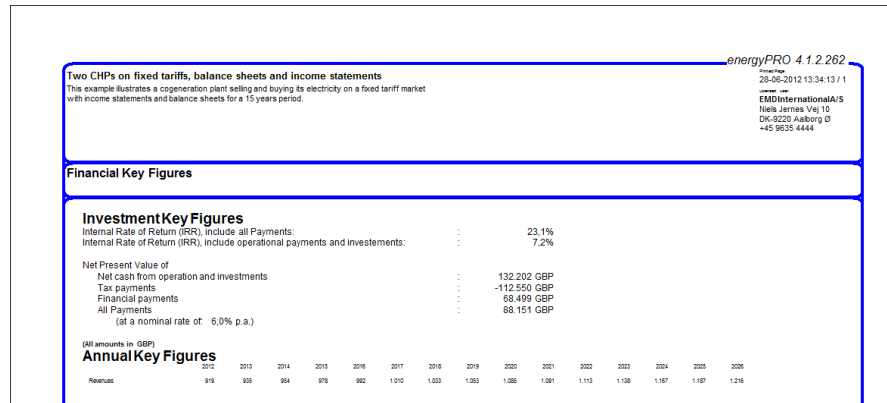

Figure 3.25: Internal rate of Return, Net present value and Annual Key Figures is to be found in the report Financial Key Figures.

3.2.3 Internal rate of return

What Does Internal Rate Of Return - IRR Mean?

The IRR is the discount rate that makes the net present value of all cash flows from a particular project equal to zero. Generally speaking, the higher a project's internal rate of return, the more desirable it is to undertake the project. As such, IRR can be used to rank considered projects. Assuming all other factors are equal among the considered projects, the project with the highest IRR would probably be considered the best.

How is the IRR found

The IRR is found by iterations using Newton's method.

The series of payments must contain at least one negative value (investment) and one positive value (income) to calculate the IRR.

To promote that the IRR is found and is determined unambiguous the series of payments must start with an investment followed by payments all positive.

If the created time series contain more negative values than the initial investment, there might be more solutions causing the IRR to be ambiguous. Another problem might be that the iteration routine finding the IRR will not converge. In that case a message in the "Financial key figures"-report will tell that the IRR is "Not found".

There will be cases, where the time series start with a positive value (income) before the investments will cause the iteration routine finding the IRR will not to converge.

The monthly-based IRR might show the most correct IRR while the annual based IRR in some cases will be more robust. In the annual case, some months with negative values might be eliminated when summed up annually.

NOTICE that energyPRO calculates the actual cash flows in the planning periods, and not cash flows expressed in the price level of a certain year. That is to say, that energyPRO calculates the Nominal IRR, whereas you in a spread sheet often calculate Real IRR, expressed in the first year price level.

The difference between the Nominal and the Real IRR is in practice equal to the average inflation in the planning period.

3.2.4 Payback time

energyPRO only offer you one Pay Back Time.

This Pay Back Time is defined as the month, in which you are able to pay back your loans (the month in which the money in the cash account equals remaining debts in the loans).

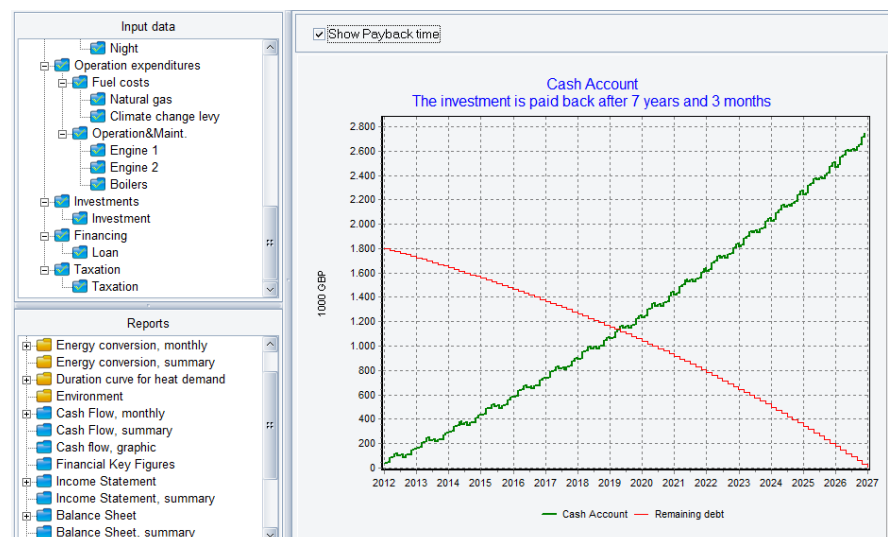

Figure 3.26: The Pay Back Time is defined as the month, in which you are able to pay back your loans.

The warning about Internal rate of return is also relevant, if you are going to use Pay Back Time.

Please be very carefull not to include payments, that would exist, even without the investments.

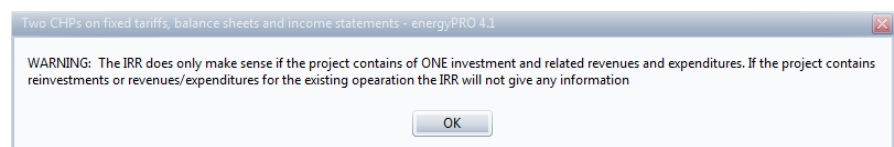

Figure 3.27: The warning about Internal rate of return is also relevant, if you are going to use Pay Back Time

3.3 Method of solar calculation in energyPRO

In energyPRO a solar collector producing heat and a photovoltaic producing electricity can be modelled. Setting up the units is based on time series with solar radiation and ambient temperature, information about location, orientation and performance (found in datasheets from the manufacturer).

3.3.1 Definitions

α	[°]	Solar altitude angle ($90^\circ - \theta_z$)
ϕ	[°]	Latitude
δ	[°]	Solar declination angle
γ	[°]	Orientation of inclined plane, south = 0° , west = 90°
γ_t	[]	Temperature coefficient for photovoltaic module efficiency
θ	[°]	Angle of incidence of beam radiation on inclined plane
θ_l	[°]	Longitudinal angle of incidence of beam radiation on inclined plane
θ_t	[°]	Transversal angle of incidence of beam radiation on inclined plane
ω	[°]	Hour angle
ρ	[]	Reflection factor
θ_z	[°]	Solar zenith angle
λ_{misc}	[]	Losses from the photovoltaic-module to the grid
a	[]	Incidence angle modifier coefficient
A	[m ²]	Total solar collector area
A_l	[]	Anisotropy index
f	[]	Modulating factor
I	[W/m ²]	Total radiation on a horizontal plane
I_b	[W/m ²]	Beam radiation on a horizontal plane
I_d	[W/m ²]	Diffuse radiation on a horizontal plane
I_{diff}	[W/m ²]	Diffuse radiation on an inclined plane
I_{dir}	[W/m ²]	Beam radiation on an inclined plane
I_o	[W/m ²]	Extraterrestrial radiation on a horizontal plane
I_{ref}	[W/m ²]	Ground reflected radiation on an inclined plane
I_s	[W/m ²]	Total radiation on an inclined plane
I_{sc}	[W/m ²]	Solar constant, 1367 W/m ²
I_{bn}	[W/m ²]	Beam radiation at normal incidence
I_{on}	[W/m ²]	Extraterrestrial radiation at normal incidence
I_{STC}	[W/m ²]	Radiation at standard conditions (1000 W/m ²) (photovoltaic)
K_θ	[]	Incidence angle modifier
$K_\theta(\theta_l)$	[]	Longitudinal incidence angle modifier
$K_\theta(\theta_t)$	[]	Transversal incidence angle modifier
a_1	[W/(m ² °C)]	First-order coefficient in collector efficiency equation
a_2	[W/(m ² °C ²)]	Second-order coefficient in collector efficiency equation
K_T	[]	Ratio of total radiation on a horizontal plane to Extraterrestrial radiation
n	[]	Day of year

n_0	[]	Intercept (maximum) of the collector efficiency
NOCT	[°C]	Nominal Operating Cell Temperature (photovoltaic)
P_{pv}	[W]	Electricity production from a Photovoltaic module
P_{max}	[W]	Installed capacity, photovoltaic
P_{elec}	[W]	Electricity production to the grid from the photovoltaic plant
R_b	[]	Ratio of beam radiation on an inclined plane to beam on horizontal
R_d	[]	Ratio of diffuse radiation on an inclined plane to diffuse on horizontal
R_r	[]	Ratio of reflected radiation on an inclined plane to total radiation on horizontal
s	[°]	Inclination of surface
t_a	[°C]	Ambient temperature
t_m	[°C]	Solar collectors average temperature
T_{cell}	[°C]	Photovoltaic operation cell temperature
T_{STC}	[°C]	The cell temperature at standard conditions (25 °C) (photovoltaic)
T_{TST}	[h]	True Solar Time
T_z	[h]	Zone time or local time
T_j	[h]	Equation of time
K	[°]	Local Constant
Cor_{DST}	[h]	Correction for daylight saving time

3.3.2 External conditions

External time series are needed to calculate the solar radiation on an inclined plane in energyPRO.

These time series include solar radiation. Optimally, the solar radiation is divided into beam radiation, I_b and diffuse radiation, I_d . Alternately, the solar radiation comes as total radiation, I .

If the solar radiation comes as total radiation the diffuse and the beam radiation can be calculated as follows (Reindl, D.T, et al., "Diffuse Fraction Correlations" Solar Energy, vol. 31, No 5, October 1990):

Interval: $0 \leq K_T \leq 0,3$	Constraint: $I_d/I \leq 1,0$	$I_d / I = 1,020 - 0,254 * K_T + 0,0123 * \sin \alpha$
Interval: $0,3 < K_T < 0,78$	Constraint: $0,1 \leq I_d/I \leq 0,97$	$I_d / I = 1,400 - 1,749 * K_T + 0,177 * \sin \alpha$
Interval: $0,78 \leq K_T$	Constraint: $0,1 \leq I_d/I$	$I_d / I = 0,486 * K_T + 0,182 * \sin \alpha$

Where K_T is the ratio of total radiation on a horizontal plane to extraterrestrial radiation:

$$K_T = \frac{I}{I_o}$$

I_o is defined as:

$$I_o = I_{sc} * \cos \theta_z$$

where I_{sc} is the solar constant, 1367 w/m²

θ_z is the solar zenith angle, described in section 3.3.3.

The beam radiation is

$$I_b = I - I_d$$

3.3.3 Radiation on solar collector or photovoltaic

This section describes the calculation of radiation on unshaded surface. Section 3.3.4 contains the effects of array shading.

The time series with solar radiation are radiation on horizontal plane. Most often the solar collector or photovoltaic is inclined. Therefore the first task is to convert the radiation on horizontal to the inclined plane.

Beam radiation

The relation between the beam radiation on an inclined plane and the beam radiation on horizontal is giving by the factor R_b .

$$R_b = \frac{\cos \theta}{\cos \theta_z}$$

where θ is angle of incidence of beam radiation on inclined plane.

The solar zenith angle is specified by the formula:

$$\cos \theta_z = \sin \delta * \sin \phi + \cos \delta * \cos \phi * \cos \omega$$

where δ is the solar declination angle

ϕ is the latitude

ω is the hour angle

The solar declination angle is approximately specified by:

$$\delta = 23,45 * \sin\left(360 * \frac{284 + n}{365}\right)$$

where n is the day of the year.

The hour angle, ω is defined by:

$$\omega = 15 \frac{\text{degrees}}{\text{hour}} * (T_{\text{TST}} - 12)$$

Where T_{TST} is True Solar Time. True Solar Time is defined in the section below.

The beam radiation on an inclined plane is found by the following formula:

$$\begin{aligned} \cos \theta = & \sin \delta * \sin \phi * \cos s - \sin \delta * \cos \phi * \sin s * \cos \gamma \\ & + \cos \delta * \cos \phi * \cos s * \cos \omega \\ & + \cos \delta * \sin \phi * \sin s * \cos \gamma * \cos \omega \\ & + \cos \delta * \sin s * \sin \gamma * \sin \omega \end{aligned}$$

where s is the inclination of the plane

γ is the plane's orientation.

The beam radiation on an inclined plane:

$$I_{dir} = I_b * R_b$$

True Solar Time

The converting from local time or Zone time to true solar time is done by:

$$T_{\text{TST}} = T_z + T_j + K - \text{Cor}_{\text{DST}}$$

Where T_z is zone time or local time

T_j is the equation of time

K is the Local Constant

Cor_{DST} is correction for daylight saving time

The equation of time, T_j , is the deviation over the year between the local time and the true solar time. T_j is found by

$$T_j = 229.2 * (0.000075 + 0.001868 * \cos B - 0.030277 * \sin B - 0.014615 * \cos(2B) - 0.04089 * \sin(2B))$$

Where B is in degrees and found by

$$B = (n - 1) * \frac{360}{365}$$

Where n is number day in year.

T_j varies from approximately -15 minutes to approximately + 17 minutes.

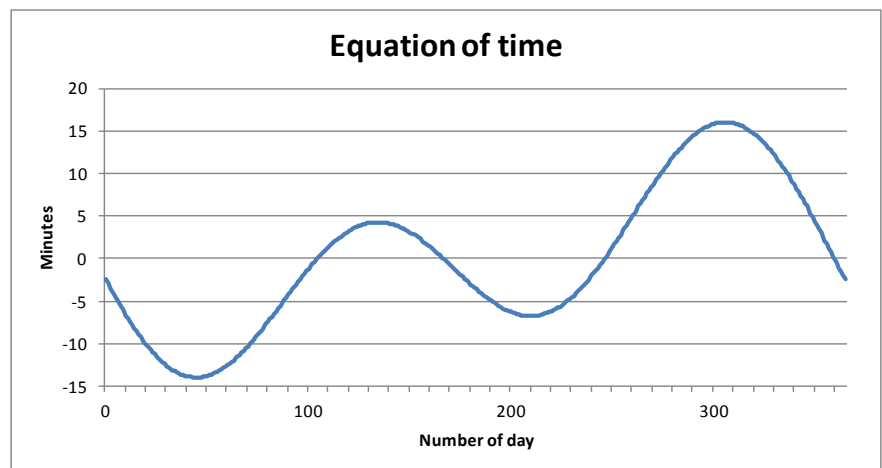

The Local Constant, K, is found by

$$K = -4 \frac{\text{min}}{\text{degree}} * (l_m - l_{st}) \text{ degree}$$

Where l_m is the standard meridian for the local time zone and l_{st} is the longitude of the location in question.

The correction, Cor_{DST} for daylight saving time has the value 1 from start to end of Daylight Saving Time and 0 in the standard time.

The true solar time shall be in the middle of each time step. If the sun rises or sets in the time step, the true solar time shall be in the middle from sunrise to end of time step when in the morning, and in the middle from start of time step and sunset, when in the evening.

Diffuse radiation

The ratio between the diffuse radiation on an inclined plane and horizontal is given by (Reindl, D.T., Beckman, W.A. and Duffie, J.A., "Evaluation of Hourly Tilted Surface Radiation Models", Solar Energy, Vol. 45, No. 1, (1990), pp. 9-17):

$$R_d = 0.5 * (1 - A_i) * (1 + \cos \theta) * (1 + f) * \sin^3(s/2) + A_i * R_b$$

Where A_i is Anisotropy index

f is modulating factor

A_i is defined as follows:

$$A_i = I_{bn} / I_{on}$$

Where I_{bn} is beam radiation at normal incidence

I_{on} is extraterrestrial radiation at normal incidence

f is defined as follows:

$$f = \sqrt{I_b / I}$$

The extraterrestrial radiation at normal incidence is set equal to the Solar Constant.

The beam radiation at normal incidence is found by setting $\theta = 0$. Hereby the diffuse radiation on the inclined plane:

$$I_{diff} = I_d * R_d$$

Reflected radiation

The contribution from radiation reflected from the ground is defined as follows:

$$R_r = 0.5 * (1 - \cos s) * \rho$$

Where ρ is the reflection factor

ρ depends on local conditions, a typical value is 0.2, equal to ground covered by grass.

Hereby the reflected radiation becomes

$$I_{ref} = I * R_r$$

Total radiation

The total radiation on the inclined surface is the sum of the beam, diffuse and reflected radiation:

$$I_s = I_{dir} + I_{diff} + I_{ref}$$

3.3.4 Array shading

Without array shading the calculated radiation on an inclined surface is valid for single rows of surface. Often, large scale solar collector or photovoltaic systems will be mounted on the ground in rows. The radiation will be reduced on the subsequent rows.

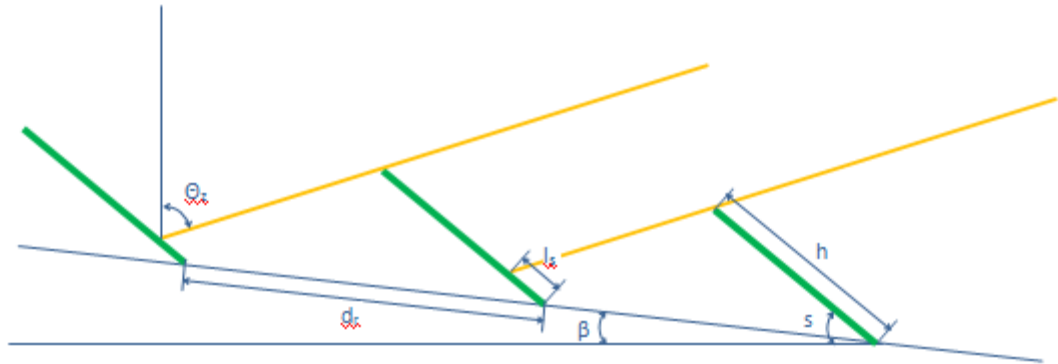

The reduction of the radiation depends on the following input data or solar data:

- β_{gr} [°] The inclination of the ground
- γ_{gr} [°] The orientation of the ground related to south
- s [°] The inclination of the surfaces
- γ_{surf} [°] The orientation of the surfaces related to south
- h [m] The height of surfaces
- d_r [m] The distance between the rows related to the ground
- ϕ [°] The latitude of location
- N_{rows} [] The number of rows
- ω [°] The solar hour angle
- θ_z [°] The solar zenith angle

Beam radiation

If the inclination of the ground is zero, the surfaces of the solar collectors or PVs are orientated at south and the sun is in south, the length of the shadow can be calculated by the use of sinus relations:

$$l_s = h - \frac{d_r}{\sin(180 - s - (90 - \theta_z))} * \sin(90 - \theta_z)$$

However, the ground can have any inclination in any direction, the surfaces can have any inclination in any direction and the sun is deviating from south most of the day.

We need to find the length of the shadow on the surface in the hour angle plane, ω .

$$l_{s\omega} = h_{\omega} - \frac{d_{r\omega}}{\sin(180 - s'_{\omega} - (90 - (\theta_z - \beta_{gr,\omega})))} * \sin(90 - (\theta_z - \beta_{gr,\omega}))$$

Where $l_{s\omega}$ is the length of the shadow on the surface
 h_{ω} is the height of the surface
 $d_{r\omega}$ is the distance between the rows
 s'_{ω} is the surface's inclination related to the ground
 $\beta_{gr,\omega}$ is the inclination of the ground
 All in the hour angle plane, ω .

The height of the surface in the hour angle, h_{ω} is found by the following cosine relation:

$$h_{\omega} = \sqrt{h_{gr\omega}^2 + (\sin s * h)^2 - 2 * h_{gr\omega} * (\sin s * h) * \cos(90 - (\beta_{gr,surf\omega} - \beta_{gr\omega}))}$$

Where $h_{gr\omega}$ is the height of the surface, when projected down on the ground:

$$h_{gr\omega} = \frac{\cos s * h}{\cos(\beta_{gr,surf\omega} - \beta_{gr\omega}) * \cos \omega}$$

The inclination of the ground in the hour angle, $\beta_{gr,\omega}$ is found by:

$$\beta_{gr,\omega} = \text{asin}(\sin \beta_{gr} * \cos(\omega - \gamma_{gr}))$$

The distance between the rows in the hour angle, $d_{r\omega}$ is found by:

$$d_{r\omega} = \frac{\cos \beta_{gr,surf}}{\cos(\omega - \gamma_{surf}) * \cos \beta_{gr,\omega}} * d_r$$

$\beta_{gr,surf}$ is the ground's inclination in the orientation of the surfaces:

$$\beta_{gr,surf} = \text{asin}(\sin \beta_{gr} * \cos(\gamma_{surf} - \gamma_{gr}))$$

The surface's inclination in the hour angle related to the inclination of the ground:

$$s'_{\omega} = \text{arcsin}\left(\frac{\sin(90 - \beta_{gr\omega}) * \sin s * h}{h_{\omega}}\right)$$

The part of the total surface area in shadow, Sh_{frac} is calculated as follows:

$$Sh_{frac} = \frac{(N_{rows} - 1) * \min\left(\frac{l_s}{h_{\omega}}, 1\right)}{N_{rows}}$$

Where N_{rows} is the number of rows.

With correction for array shading the beam radiation becomes:

$$I_{dir} = I_b * R_b * (1 - Sh_{frac})$$

Diffuse radiation

The shadow impact on the diffuse radiation is visualized below:

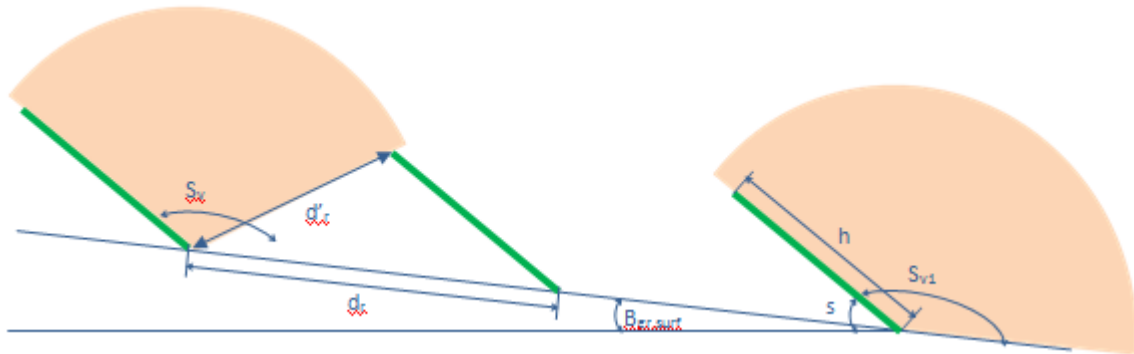

Where S_v is the angle of sky view of the rows affected by shading of preceding row and S_{v1} is the sky view of the first row, which is not affected by shading, but where the inclination of the ground in the orientation of the surfaces is taking into consideration.

$$S_{v1} \text{ is equal to } 180 - (s - \beta_{gr, surf})$$

The ratio between the diffuse radiation on first row and horizontal, R_{d1} is given by:

$$R_{d1} = 0,5 * (1 - A_I) * (1 + \cos(s - \beta_{gr, surf})) * (1 + (f) * \sin^3(s/2)) + A_I * R_b$$

The ratio between the diffuse radiation on subsequent rows and horizontal, R_d is given by:

$$R_d = 0,5 * (1 - A_I) * (1 + \cos(180 - s_v)) * (1 + (f) * \sin^3(s/2)) + A_I * R_b * (1 - Sh_{frac})$$

The height of the collector is split in 10 pieces. The S_v and R_d is calculated at the middle for each of them and the average R_d is used.

S_v is found by the following cosine relation:

$$S_v = \arccos\left(\frac{h^2 + d_r'^2 - d_r^2}{2 * h * d_r'}\right)$$

Where d_r' is the distance between the bottom of the row and the top of the preceding row.

d'_r is found by the following cosine relation:

$$d'_r = \sqrt{h^2 + d_r^2 - 2 * h * d_r * \cos(s - \beta_{gr,surf})}$$

The resulting $R_{d,sh}$ becomes:

$$R_{d,sh} = \frac{((N_{rows} - 1) * R_d + R_{d1})}{N_{rows}}$$

The diffuse radiation on the inclined surface when taking shading into consideration becomes:

$$I_{diff} = I_d * R_{d,sh}$$

Reflected radiation

The reflected radiation ratio when taking shading into consideration is divided into the beam, $R_{r,b}$ and diffuse, $R_{r,d}$ radiation. Further, the ratio is different for the first, R_{r1} and the following rows, R_{rn} .

Beam and diffuse reflected radiation on the first rows are given as:

$$R_{r1,b} = R_{r1,d} = 0.5 * (1 - \cos(s - \beta_{gr,surf})) * 0.2$$

The reflected radiation on the proceeding rows is calculated as ratio of the reflected radiation on the first row, r_{p-1} .

The beam reflected radiation on the proceeding rows depends on the length of the beam on the ground, l_{sun} . The length is zero if the surface is partly in shade, meaning that no beam radiation reach the ground in front of the row.

If the length of the beam on the ground is equal to h , $r_{p-1,b}$ is set to 1. The length is calculated as follows:

$$l_{sun} = d_{r\omega} - \frac{h_{\omega}}{\sin(90 - \theta'_{z\omega})} * \sin(180 - s'_{\omega} - (90 - \theta'_{z\omega}))$$

And $r_{p-1,b}$ becomes:

$$r_{p-1,b} = \frac{l_{sun}}{h}$$

$$R_{rn,b} = R_{r1,b} * r_{p-1,b}$$

The reflected beam radiation, $R_{r,b}$ becomes:

$$R_{r,b} = \frac{((N_{rows} - 1) * R_{rn,b} + R_{r1,b})}{N_{rows}}$$

The reflected diffuse radiation on the proceeding rows as ratio of the reflected diffuse radiation on the first row, $r_{p-1,d}$ has been defined as follows:

$$r_{p-1,d} = \frac{S_v}{(180 - (s - \beta_{gr,surf}))}$$

The diffuse reflected radiation, $R_{rn,d}$ becomes:

$$R_{rn,d} = R_{r1,d} * r_{p-1,d}$$

The overall reflected diffuse radiation, $R_{r,d}$ becomes:

$$R_{r,d} = \frac{((N_{rows} - 1) * R_{rn,d} + R_{r1,d})}{N_{rows}}$$

The reflected radiation on the inclined surface when taking shading into consideration becomes:

$$I_{ref} = I_b * R_{r,b} + I_d * R_{r,d}$$

3.3.5 Solar Collector

The formula for a solar collector is as follows (without Incidence angle modifier):

$$Y = A * (I_s * n_o - a_1 * (t_m - t_a) - a_2 * (t_m - t_a)^2)$$

where

- Y: Heat production, [W].
- A: Solar collector area [m²]
- I_s: Solar radiation on solar collector, [W/m²]
- t_m: The collectors average temperature, [°C], that is an average between the temperature of the cold water entering the collector and the hot water leaving the collector
- t_a: The ambient temperature, [°C]. For the best results the ambient temperatures should be hourly.

The efficiency of the solar collector is defined by three parameters:

- n_o: Intercept (maximum) of the collector efficiency, [-]
- a₁: The first-order coefficient in collector efficiency equation, [W/(m² °C)]

a_2 : The second-order coefficient in collector efficiency equation, $[W/(m^2 \cdot ^\circ C)^2]$

These 3 parameters are available for collectors tested according to ASHRAE standards and rated by SRCC (ASHRAE, 2003; SRCC,1995), as well as for collectors tested according to the recent European Standards on solar collectors (CEN, 2001). Many examples of collector parameters can be found on the internet (e.g. SPF, 2004).

Note: It is important to make sure that collector area entered as a parameter match the area used when determining the values of n_o , a_1 and a_2 . Typically, efficiency curves are provided for gross area in the US and aperture area in Europe.

Furthermore, the model includes Incidence Angle Modifier, IAM or K_θ . The sun is not always located perpendicular to the collector plane; the incidence angle generally changes both during the course of a day and throughout the year. The transmittance of the cover glazing for the collector changes with the incidence angle.

3.3.6 Incidence angle modifier, Flat plate solar collector

Typically, the Incidence angle modifier for a flat plate solar collector looks as below:

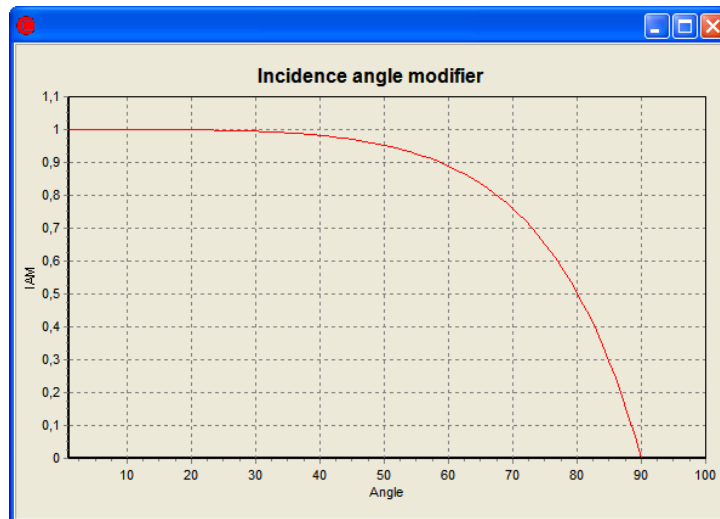

Figure 3.28 The incidence angle modifier

It can also be defined as follow:

$$K_\theta = 1 - \tan^a(\theta/2)$$

where

θ is the incidence angle on the collector.

a is the measured coefficient.

Including K_θ the formula for the heat production from the solar collector becomes:

$$Y = A * \left((I_{beam} * K_{\theta} + (I_{diffuse}) * K_{60^{\circ}}) * n_o - a_1 * (t_m - t_a) - a_2 * (t_m - t_a)^2 \right)$$

The radiation is split into beam radiation and diffuse radiation. Since the diffuse radiation per definition has no incidence angle the IAM at 60° is used.

3.3.7 Incidence angle modifier, Evacuated tube solar collector

Evacuated tube collectors are optically non-symmetric.

The longitudinal incidence angle is measured in a plane that is perpendicular to the collector plane and contains the collector azimuth. The corresponding IAM is referred to as the longitudinal IAM, or altitude modifier.

The transversal incidence angle is measured in a plane that is perpendicular to both the collector aperture and the longitudinal plane. The corresponding IAM is referred to as the transversal IAM, or azimuthal modifier.

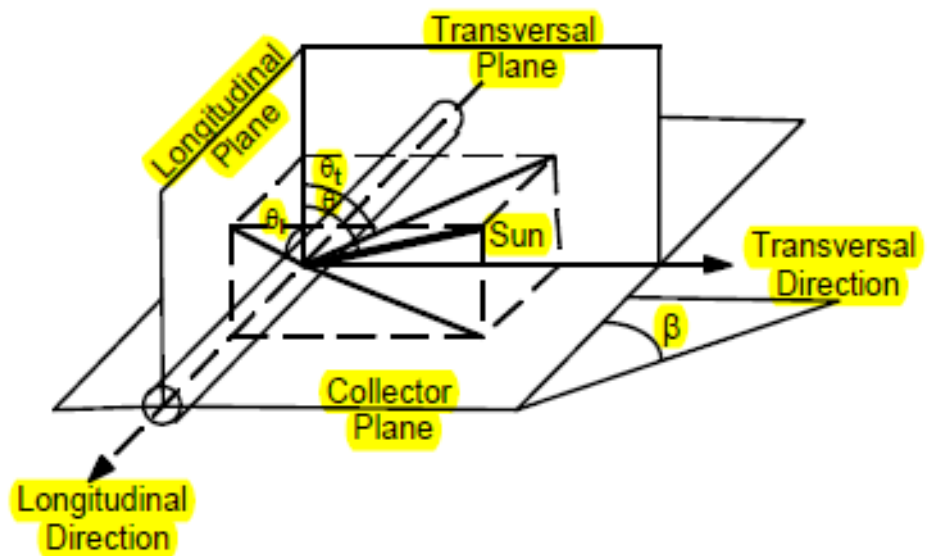

The Longitudinal incidence angle, θ_l is found by:

$$\theta_l = \arcsin(\sin(\theta_z * \cos(\omega - \gamma)) - s)$$

where

θ_z is the Solar zenith angle

ω is the hour angle

γ is the orientation of the solar collector

s is the inclination of the solar collector.

And transversal incidence angle, θ_t is found by:

$$\theta_t = \text{abs} \left(\text{atan} \left(\frac{\sin \theta_z * \sin(\omega - \gamma)}{\cos \theta} \right) \right)$$

where

θ is the angle of incidence of beam radiation on inclined plane.

When specifying the evacuated tube solar collector, the IAM is specified for both the longitudinal and the transversal incidence angle.

The overall Incidence Angle Modifier for beam radiation, $K_{\theta}(\theta_l, \theta_t)$ is found by:

$$K_{\theta}(\theta_l, \theta_t) = K_{\theta}(\theta_l) * K_{\theta}(\theta_t)$$

The values of $K_{\theta}(\theta_l)$ and $K_{\theta}(\theta_t)$ is found by interpolating between the nearest values in the table of Incidence angle modifier.

The IAM for diffuse radiation is calculated by evaluating the ratio of absorbed diffuse radiation over to incident diffuse radiation over the sky dome for a horizontal collector, assuming isotropic diffuse radiation:

$$K_{\theta_{diff}} = \frac{4}{\pi} \int_{\frac{\pi}{2}}^{\frac{\pi}{2}} \int_{\frac{\pi}{2}}^{\frac{\pi}{2}} K_{\theta}(\theta, \omega) * \cos \theta * \sin \theta * d\theta * d\omega$$

This integration is performed once at the start of the simulation, with the user supplied IAM data.

Including K_{θ} the formula for the heat production from the solar collector becomes:

$$Y = A * \left((I_{beam} * K_{\theta} + (I_{diffuse}) * K_{\theta_{diff}}) * n_o - a_1 * (t_m - t_a) - a_2 * (t_m - t_a)^2 \right)$$

3.3.8 Photovoltaic

The electricity production from a Photovoltaic module, P_{pv} , can be expressed as follows:

$$P_{pv} = P_{Max} * \frac{I_s}{I_{STC}} * [1 - \gamma_s * (T_{cell} - T_{STC})]$$

where

P_{max} : Installed capacity [W]

- I_s : Solar radiation [W/m^2]
- I_{STC} : Radiation at standard conditions ($1000 W/m^2$) [W/m^2]
- γ_s : Temperature coefficient for module efficiency [-]
- T_{cell} : Operation cell temperature [$^{\circ}C$]
- T_{STC} : The cell temperature at standard conditions ($25^{\circ}C$) [$^{\circ}C$]

The operation cell temperature is calculated by the following formula (Antonio Luque and Steven Hegedus (2003)):

$$T_{cell} = T_a + I_s * \left(\frac{NOCT - 20^{\circ}C}{800W / m^2} \right)$$

where

- T_{at} : Ambient temperature
- NOCT: Nominal Operating Cell Temperature

Hereto come losses from the pv-module to the grid, λ_{misc} , such as miscellaneous PV array losses and other power conditioning losses.

The power production at grid becomes:

$$P_{elec} = P_{pv} * (1 - \lambda_{misc})$$

3.4 Method of wind farm calculation in energyPRO

The wind farm model in energyPRO covers three different cases.

1. Annual production calculated
 - a. Power curve used directly
 - b. Power curve is scaled to another level
2. Fixed annual production (wind speed is scaled)

3.4.1 Definitions

$WS_m(t)$	= Wind speed measured (m/s) at time t
$WS_c(t)$	= Wind speed calculated (m/s) at time t
H_m	= Height of measurements (m)
H_h	= Hub Height (m)
α	= Hellmann coefficient
m_f	= Wind speed modification factor
$PC(WS_c(t))$	= then power from the power curve based on the calculated wind speed at hub height and linear interpolation on power curve.
P_{MaxPC}	= Max power value found in power curve
P_{Max}	= Max Power stated
$P(t)$	= Production at time t
$P_{annualDesired}$	= Annual production desired (MWh)
$P_{annualCalc}$	= Annual production calculated (MWh)

3.4.2 Mathematical description

Wind speed at hub height

Calculated wind speed at hub height in cases 1a and 1b.

$$(1) WS_c(t) = WS_m(t) * \left(\frac{H_h}{H_m} \right)^\alpha$$

Calculated wind speed at hub height in case 2.

$$(2) WS_c(t) = WS_m(t) * \left(\frac{H_h}{H_m} \right)^\alpha * m_f,$$

Where the modification factor is found through iterations.

Calculation of production at time t

$$(3) P(t) = PC(WS_C(t)) \quad (\text{Case 1a})$$

$$(4) P(t) = PC(WS_C(t)) * P_{\max} / P_{\max PC} \quad (\text{Case 1b})$$

$$(5) P(t) = PC(WS_C(t)) \quad (\text{Case 2})$$

Where $PC(WS_C(t))$ return the power from the power curve based on the calculated wind speed at hub height and linear interpolation on power curve.

Calculation of modification factor

$$(6) P_{\text{annualCalc}} = \sum_{t=0}^{t=H_{\text{Year}}} PC(WS_C(t)) * \Delta T, \text{ where } WS_c(t) = WS_m(t) * \left(\frac{H_h}{H_m} \right)^\alpha * m_f$$

Start guess $m_{f=1}$

In each Iteration is the annual production calculated (6) and compared with the desired value

If $P_{\text{annualCalc}} > P_{\text{annualDesired}}$ then decrease m_f

If $P_{\text{annualCalc}} < P_{\text{annualDesired}}$ then increase m_f

This is repeated until

$$P_{\text{annualCalc}} \cong P_{\text{annualDesired}}$$

then m_f is found

4 Functions in energyPRO

4.1 Introduction

This chapter is a reference section for functions and formulas in energyPRO.

There are five areas in energyPRO containing formula fields. In each of those areas there is a set of standard mathematical functions and some specialized functions available. These areas are:

- Time series functions
- Demands
- Energy Units
- Economy (Revenues and operational expenditures)
- Economy (Taxation)
- Economy (Define annual key figures)



If functions are available, this is indicated by the Fx-button (Taxation and Define annual key figures excluded). Pressing this button invokes a window telling which functions are available for creating formulas.

General functions: The structure in this chapter is as follows. First, the general functions available in all or most of the formula fields in energyPRO is presented, see section 4.2. The general functions are the only functions available in “Time series functions” and “Demands”.

Time series functions: In section 4.3 functions to be used in time series only are described

Functions concerning load curves: In section 4.44 additional functions used for describing the production units load curves are presented. These functions describes how to access productions and consumptions on other production units

Functions concerning operational payments: In section 4.55, functions available for defining Revenues and Operation Expenditures payments are described. Those functions are divided into three groups. In section 4.5.1 functions concerning energy conversion on system level are described. In section 4.5.2 functions concerning energy conversion on production unit level are described. Finally, section 4.5.3 contains description of miscellaneous functions.

Functions concerning Taxation: In section 0 the functions to be used for defining Taxation payments are described.

Functions concerning Annual key figures: Finally, in section 4.7 functions used to define “Annual key figures” are described.

4.2 Functions used in all (or more) formula fields

Available in all formula fields are standard mathematical functions shown in Table 4.1.

Standard mathematical functions
+ , - , * , / , ^
Abs(value1)
Arctan(value1)
Cos(value1)
Exp(value1)
Frac(value1)
Int(value1)
Trunc(value1)
Ln(value1)
Pi
Round(value1)
Sin(value1)
Sqr(value1)
Sqrt(value1)
Min(value1;value2)
Max(value1;value2)

Table 4.1: Standard mathematical functions available in all formula fields in energyPRO

Other functions
Ceil
Floor
Z
“Time series reference

The last functions are described below.

Ceil

Returns an integer value rounding a real number up to nearest integer.

Syntax

Ceil(Value1)

Argument	Description
----------	-------------

Value1	Real number
--------	-------------

Returning unit	Integer
----------------	---------

Example

Ceil(11.5) = 12

Floor

Returns an integer value rounding a real number down to nearest integer.

Syntax

Ceil(Value1)

Argument	Description
----------	-------------

Value1	Real number
--------	-------------

Returning unit	Integer
----------------	---------

Example

Floor(11.5) = 11

Time series reference

Returns values from a time series established under external conditions or demands. Present only available in "Time series functions" and "Production Units".

Syntax *Symbol*(_)

Argument	Description
----------	-------------

Symbol	The symbol used to define a time series
--------	---

Returning value	Value corresponding with date and time from time series established under external conditions or demands
-----------------	--

Returning unit	-
----------------	---

Description

Is used when the load curve of a production unit is dependent of a time series. The function extract values from the specified time series.

Examples

HD(_) extract the values form the time series HD, where HD is the symbol of a time series, e.g. heat demand.

T(_)extract the values from the time series T, where T could be the symbol of a time series from external conditions describing the fluctuations in temperatures during a year.

Z

Z is a step-function that returns a value between 0 and 1

Syntax

Z(function, *Fmin*, *Fmax*)

Argument	Description
----------	-------------

	<i>Function</i>	The function, T
	<i>Fmin</i>	Minimum value
	<i>Fmax</i>	Maximum value
	Returning value	Function value between 0 and 1
	Returning unit	-
<i>Description</i>	Z is a step function, that returns the value 0, when $T \leq F_{min}$, 1, when $T > F_{max}$, and a linear interpolated value between 0 and 1 when T is between Fmin and Fmax.	
<i>Example</i>	Z(T(_);0;10;). Use the time series with the symbol T. The argument to T,- (_) refers the actual time. In that case the Z-function returns: <ul style="list-style-type: none"> - 0 if the actual temperature is zero or below - 0.5 if the temperature is 5°C - 1 if the temperature is above 10°C 	

4.3 Functions used only in Time series functions

Calcstart

Returns the Start date specified in the project identification.

Syntax

Calcstart

Argument	Description
----------	-------------

Availability	External contditons, Time series funcntions only
Returning unit	Real number

Example

If the calculations starttime is 01-01-2012 then Calcstart returns 40909

Intervals

Based on an existing time series, the function generates a new time series with a specified number of intervals omitting a percentage of extreme values.

Syntax

Intervals(TSSymbol, NoOfIntervals,EkstremeValuesPct)

Argument	Description
----------	-------------

<i>TSSymbol</i>	Name of time series symbol
NoOfIntrvals	Number of intervals in prognosis
ExtremeValue sPct	Percentage of extremevalues (both high and low) to be omitted
Returning	Value in actual time stamp

value
 Returning unit -

Description This function is made for backward compatibility of the way of generating prognosis for electricity spot prices were done prior to energyPRO version 4.2. Based on an existing time series, the function generates a new time series with a specified number of intervals omitting a percentage of extreme values. All intervals have the same length. All values from the mother time series are then put in the corresponding interval. The intervals are created based on monthly values

Example *Intervals(Spot;5;2), Where a time series with 5 intervals omitting the highest and lowest 2 percent value.*

TSMean

Returns a time series mean value for a specified period.

Syntax Calcstart(Symbol,value1,value2)

Argument	Description
Symbol	Time series symbol
Value1	Number, Date or calcstart function
Value2	Number Date or calcstart function
Returning unit	Real number

Description This function return the mean value for a specified period. The period can be specified by a values (<1000) then the argument is interpreted as offset from the actual timestamp otherwise it is interpreted as a data

Examples
 TSMean(T;CalcStart-1,2)
 TSMean(T;Floor(CalcStart),2)
 TSMean(T;01-01-2012;08-01-2012)
 TSMean(T;-1;-0)

4.4 Functions used only in Production units load curves

The names of functions starting with **PaP** (Production already Planned) have in common that they extract information about productions/consumptions taking place on production units on which a production has already been planned (in the actual time step). In practice, these values are available on units having a higher priority in

the operation strategy than the actual production unit. If units have a lower priority they return a zero. The PaP-functions are:

Name	Returns	Unit
PapElcons(name)	Already Planned electricity consumption	MW
PapElProd(name)	Already Planned electricity production	MW
PapCool(name)	Already Planned Cooling production	MW
PapFuel(name)	Already Planned Fuel consumption	MW
PapHeat(name)	Already Planned Heat production	MW
PapProcHeat(name)	Already Planned Process Heat production	MW

Table 4.2: Already Planned functions to be use for describing load curves

Name is the specified name the of production unit on which the actual load-curve depend.

PapElCons

Returns the already planned electricity consumption on a specified unit.

Syntax

PapElCons(*Name*)

Argument	Description
<i>Name</i>	Name of the production unit or 0 (zero). Zero means all units
Returning value	Actual electricity production load on specified production unit(s) MW

Description

This function is used in situations where the load on the actual production unit depends on the electricity consumption load on other production unit(s).

Be aware that the production unit(s) addressed must have a higher priority in the operation strategy than the production unit on which it is used, otherwise the function returns a zero.

Examples

The following two examples show the use of PapElCons

PapElCons(WoodBoiler) returns the actual load of Electricity consumption on “WoodBoiler”.

PapElCons(0) return the actual load of electricity consumption on all production units having a higher priority in the operation strategy.

PapElProd

This function returns the already planned electricity production from a specified production unit.

Syntax

PapElProd(*Name*)

Argument	Description
<i>Name</i>	Name of the production unit or 0 (zero). Zero means all units
Returning value	Actual load on production unit(s)
Returning unit	MW

Description

This function is used in situations where the load on the actual production unit depends on the electricity production load on other production unit(s).

Be aware that the production unit(s) addressed must have a higher priority in the operation strategy than the production unit on which it is used, otherwise the function returns a zero.

Examples

The following two examples show the use of PapElProd:

PapElProd(CHP) returns the actual load of electricity production from "CHP".

PapElProd(0) returns the actual load of electricity production from all production units having a higher priority in the operation strategy.

PapCool

Returns the already planned cooling production from a specified production unit.

Syntax PapCool(*Name*)

Argument	Description
<i>Name</i>	Specified of the production unit or 0 (zero). Zero means all units
Returning value	Actual cooling load on production unit(s)
Returning unit	MW

Description

This function is used in situations where the load on the actual production unit depends on the cooling production load on other production unit(s).

Be aware that the production unit(s) addressed must have a higher priority in the operation strategy than the production unit on which it is used; otherwise, the function returns a zero.

Examples

The following two examples show the use of PapCool

PapCool(Cooler) returns the actual load of cooling production from “Cooler”.

PapCool(0) returns the actual load of cooling production from all production units having a higher priority in the operation strategy.

PapFuel

Returns the already planned production of heat on a specified unit.

Syntax PapFuel(*Name*)

Argument	Description
<i>Name</i>	Name of the production unit or 0 (zero). Zero means all units
Returning value	Actual load on production unit(s)
Returning unit	MW

Description

The function might be used in situations where the fuel consumption on the actual production unit depends on the fuel consumption on other production unit(s).

Be aware that the production unit(s) addressed must have a higher priority in the operation strategy than the production unit on which it is used, otherwise the function returns a zero.

Examples

The following two examples show the use of PapFuel

PapFuel(Boiler 1) returns the actual fuel consumption on “Boiler 1”.

PapFuel(0) return the actual fuel consumption on all production units having a higher priority in the operation strategy.

PapHeat

Returns the already planned heat production from a specified unit.

Syntax

PapHeat(*Name*)

Argument	Description
<i>Name</i>	Name of the production unit or 0 (zero). Zero means all units
Returning value	Actual load on production unit(s)
Returning unit	MW

Description

This function is used in situations where the load on the actual heat production unit depends on the heat production load on other production unit(s).

Be aware that the production unit(s) addressed must have a higher priority in the operation strategy than the production unit on which it is used, otherwise the function returns a zero.

Examples

The following two examples show the use of PapHeat:

PapHeat(Boiler 1) returns the actual load of heat production from “Boiler 1”.

PapHeat(0) return the actual load of heat production from all production units having a higher priority in the operation strategy.

PapProcHeat

Returns the already planned production of process heat on a specified unit.

Note: The process heating option is only relevant when the advanced setting option “Transmission of heat from plant through both high and low temperature pipes” in the Project Identification window is checked.

Syntax

PapProcHeat(*Name*)

Argument	Description
<i>Name</i>	Name of the production unit or 0 (zero). Zero means all units
Returning value	Actual load on production unit(s)
Returning unit	MW

Description

The function might be used in situations where the load on the actual process heat production unit depends on the process heat production load on other production unit(s).

Be aware that the production unit(s) addressed must have a higher priority in the operation strategy than the production unit on which it is used, otherwise the function returns a zero.

The following two examples show the use of PapProcHeat:

Examples

PapProcHeat(Boiler 1) returns the actual load of process heat production from “Boiler 1”.

PapProcHeat(0) Return the actual load of process heat production from all production units having a higher priority in the operation strategy.

4.5 Functions used only in Revenues and Operational Expenditures

There are three sets of functions relating to the energy conversion within energyPRO. Those are:

- Functions measuring on the system border
- Functions measuring on energy conversion unit level.
- Other Functions

In the figure below the system is defined as everything placed within the outer frame. By other words, the “functions measuring on the system border” is the functions measuring the flow passing this border.

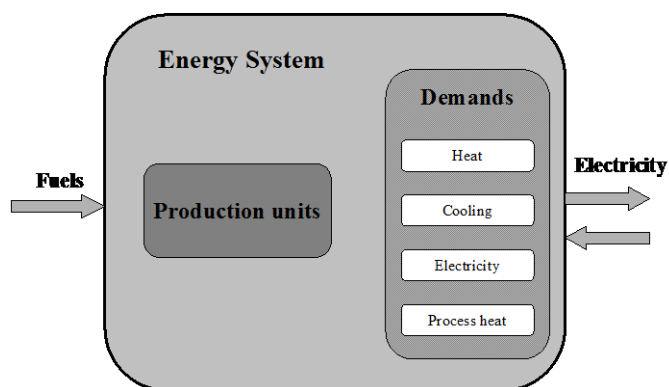

Figure 4.1: The Energy System

In practice the system border is the electrical grid or a specified transformer station, where the interaction between the considered energy system and the outside world is measured. It could for instance be a meter measuring the amount of natural gas entering the system.

The functions measuring on productions unit level are strictly related to the specific production units and demands described within the system. It could be a specified boiler, CHP-unit or a specified demand. Below you will find a description of the single functions.

When modelling economy it is important to realize that the model is monthly based. This is especially important while modelling with peak-function and the Electric-Capacity function. Not being aware of this fact might result in misleading values.

4.5.1 Functions measuring on the system border

These functions consider the energy system as a black box, and are only dealing with energy and power crossing this border, see the figure below. The arrows are indicating the flows passing the system border.

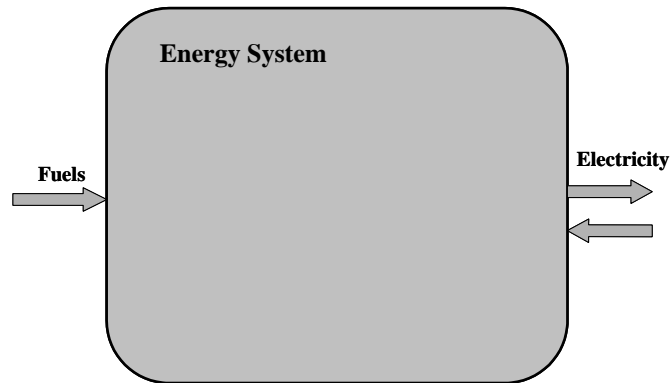

Figure 4.2: Energy System. Flows passing system border

This “System” -functions can be interpreted as meters placed on the system border measuring flows crossing the system border.

The functions are for instance valuable in situations, where payments are independent of which unit it is concerning.

Name	Returns	Unit
AccExportedElectricity (Market,PriorityPeriod)	Accumulated monthly amount for exported electricity to market	MWh
AccImportedElectricity (Market ,PriorityPeriod)	Accumulated monthly amount for imported electricity from market	MWh
AccImportedFuel(Fuel)	Accumulated monthly amount of imported fuel	MWh
ExportedElectricity(Market, PriorityPeriod)	Electricity exported out off the system to the market	MWh/month
PeakExportedElectricity (Market,PriorityPeriod)	Monthly peak value for exported electricity to market	MW
PeakImportedElectricity (Market,PriorityPeriod)	Monthly peak value for imported electricity form market	MW
PeakImportedFuel(Fuel)	Monthly peak value for imported fuel	MW
PoPxDE(Market)	Monthly value of electricity exported to the grid from the market	<currency used in time series>
PoPxRE(Market)	Monthly Value of electricity imported from the grid from market	<currency used in time series>
ImportedElectricity(Market, PriorityPeriod)	Electricity imported by the system from market	MWh/month
ImportedFuel(Fuel)	Fuel imported by the system	MWh/month

Table 4.3: Functions measuring the energy passing the system border.

AccExportedElectricity

Returns the accumulated monthly amount of electricity exported to the specified market in the specified "Priority period".

Syntax AccExportedElectricity(*Market, PriorityPeriod*)

Argument	Description
<i>Market</i>	The Name of market. All markets return the accumulated amount for all markets
<i>PriorityPeriod</i>	The Name of the Priority period name specified in "Electricity markets". "All Periods" return the accumulated amount in all priority periods
Returning value	Monthly amount of energy exported to market
Returning unit	MWh/month

Description In every calculated time step within a month the amount of electricity exported to the specified market is calculated. The amount exported is calculated as the electricity produced subtracted the electricity consumed by production units and consumers within the system. If *negative* in a time step the value for that time step is set to zero, otherwise it is added to the amount of exported electricity.

The function returns the accumulated value hereof for the actual year in calculation.

Also see AcclImportedElectricity.

Examples *AccExportedElectricity(All markets, All Periods)*
AccExportedElectricity(Fixed tariff, Highload)

AcclImportedElectricity

Returns the monthly amount of electricity imported from the specified market in a specified "Priority period"

Syntax AcclImportedElectricity(*Market, PriorityPeriod*)

Argument	Description
<i>Market</i>	The Name of market. All markets return the accumulated amount for all markets
<i>PriorityPeriod</i>	The Name of the Priority period name specified in "Electricity markets". "All Periods" return the accumulated amount in all priority periods for the specified market
Returning value	Monthly amount of energy exported to the market
Returning unit	MWh/month

Description In every calculated time step within a month the amount of electricity imported from the specified market is calculated. The amount imported is calculated as the electricity produced subtracted the electricity consumed by production units and consumers within the system. If *positive* in a time step the value for that time step is set to zero, otherwise it is added to the amount of imported electricity.

The function returns the accumulated value hereof for the actual year in calculation.

Also see `AccExportedElectricity`.

Examples `AccImportedElectricity(Fixed Tariff, All Periods)`
`AccImportedElectricity(Fixed tariff, Highload)`

AccImportedFuel

Returns the Accumulated monthly amount of a specified fuel imported into the energy system.

Syntax `AccImportedFuel(Name)`

Argument	Description
<i>Name</i>	The Name of the specified fuel.
Returning value	Monthly amount of fuel imported to the system
Returning unit	MWh

Description The accumulated amount of a specified fuel consumed by all production units in actual year of calculation.

Examples `AccImportedFuel(Natural Gas)`

PeakExportedElectricity

Returns the Peak load of electricity exported to the specified market in the specified "Priority period"

Syntax `PeakExportedElectricity(Market, PriorityPeriod)`

Argument	Description
<i>Market</i>	The Name of market. All markets return the accumulated amount for all markets
<i>PriorityPeriod</i>	The Name of the Priority period name specified in "Electricity markets". "All Periods" return the accumulated amount in all priority periods
Returning value	Monthly peak of electricity exported to market
Returning unit	MW/month

Description In every calculated time step within a month the peak of electricity exported to the market is calculated. This peak is calculated as the maximum value within a month of the actual electricity consumption by production units and consumers subtracted the actual electricity production.

Also see `PeakImportedElectricity`.

Examples `PeakExportedElectricity(Flat rate, All Periods)`
`PeakExportedElectricity(Fixed Tariff, Highload)`

PeakImportedElectricity

Returns the monthly electricity peak imported from the specified market in a specified "Priority period".

Syntax PeakImportedElectricity(*Market, PriorityPeriod*)

Argument	Description
<i>Market</i>	The Name of market. All markets return the accumulated amount for all markets
<i>PriorityPeriod</i>	The Name of the Priority period name specified in "Electricity markets". "All Periods" return the accumulated amount in all priority periods
Returning value	Monthly peak of electricity imported from the specified market
Returning unit	MWh/month

Description In every calculated time step within a month the peak of electricity imported from the specified market is calculated.

The Peak is calculated as the maximum value within a month of electricity produced subtracted the electricity consumed by production units and consumers within the system. When modelling economy it is important to realize that the model is monthly based. This is especially important while modelling with peak-function and the Electric-Capacity function. If not being aware of this fact will result in much higher values than intended.

Also see PeakExportedElectricity.

Examples PeakImportedElectricity(*Fixed tariff, All Periods*)

ImportedElectricity(Fixed tariff, Highload)

PeakImportedFuel

Returns the monthly peak of a specified fuel imported to the system

Syntax PeakImportedFuel(*Name*)

Argument	Description
<i>Name</i>	The Name of the specified fuel.
Returning value	Monthly amount of fuel imported to the system
Returning unit	MWh

Description The monthly peak of a specified fuel consumed by all production units in the actual year of calculation.

Examples PeakImportedFuel(*Natural Gas*)

ExportedElectricity

Returns the monthly amount electricity exported to the specified market in a specified "Priority period".

Syntax ExportedElectricity(*Market, PriorityPeriod*)

Argument	Description
----------	-------------

<i>Market</i>	The Name of market. All markets return the accumulated amount for all markets
<i>PriorityPeriod</i>	The Name of the Priority period name specified in "Electricity markets". "All Periods" return the accumulated amount in all priority periods
Returning value	Monthly amount of energy exported to the specified market
Returning unit	MWh/month

Description In every calculated time step within a month the amount of electricity exported to the specified market is calculated. The amount exported is calculated as the electricity produced subtracted the electricity consumed by production units and consumers within the system. If *negative* in a time step the value for that time step is set to zero, otherwise it is added to the amount of exported electricity.

Also see ImportedElectricity.

Examples *ExportedElectricity(All markets,All Periods)*
ExportedElectricity(Fixed tariffs,Highload)

ImportedElectricity

Returns the monthly amount electricity imported from the specified market in a specified "Priority period".

Syntax ImportedElectricity(*PriorityPeriod*)

Argument	Description
<i>Market</i>	The Name of market. All markets return the accumulated amount for all markets
<i>PriorityPeriod</i>	The Name of the Priority period name specified in "Electricity markets". "All Periods" return the accumulated amount in all priority periods
Returning value	Monthly amount of energy imported from the specified market
Returning unit	MWh/month

Description In every calculated time step within a month the amount of electricity imported from the specified market is calculated. The amount imported is calculated as the electricity produced subtracted the electricity consumed by production units and consumers within the system. If *positive* in a time step the value for that time step is set to zero, otherwise it is added to the amount of imported electricity.

Examples *ImportedElectricity(Fixed tariffs,All Periods)*
ImportedElectricity(Fixed tariffs,Highload)

ImportedFuel

Returns the monthly amount of a specified fuel imported to the system

Syntax ImportedFuel(*Name*)

Argument	Description
----------	-------------

<i>Name</i>	The Name of the specified fuel.
<i>Returning value</i>	Monthly amount of fuel imported to the system
<i>Returning unit</i>	MWh
<i>Description</i>	The amount of a specified fuel consumed by all production units.
<i>Examples</i>	<i>ImportedFuel(Natural Gas)</i>

4.5.2 Functions measuring on energy conversion unit level.

These functions are focused on the single elements within modelled energy system. This is the production units and the demands.

The functions measuring on the energy conversion unit level can be considered as meters placed on the single energy conversion units i.e. a specified boiler, a specified CHP-unit or an electricity demand.

Energy conversion units

Below is a description of the functions that are available for the single types of units.

Those units are:

- CHP-unit
- Boiler
- User defined
- Electric heat pump
- Absorption cooler

Name	Returns	Unit
CP(eUnit)	Cooling production from eUnit	MWh/month
CPCap(eUnit)	Peak fuel capacity on eUnit	MW
EC(eUnit,PriorityPeriod)	Electricity consumption on eUnit in Period of priority	MWh/month
ECCap(eUnit)	Peak Electricity capacity on eUnit	MW
EP(eUnit,PriorityPeriod)	Electricity production from eUnit in Period of priority	MWh/month
ElectricCapacity(eUnit)	Electric Capacity for eUnit	MW
EPCap(eUnit)	Peak Electricity capacity on eUnit	MW
FC(eUnit)	Fuel consumption on eUnit	MWh/month
FCCap(eUnit)	Peak fuel capacity on eUnit	MW
HC(eUnit)	Heat consumption from	MWh/month

	eUnit	
HCCap(eUnit)	Peak heat consumption capacity on eUnit	MW
HeatBlowoff		MWh/Month
HoursOfOperation(eUnit)	Number of hours of operation for eUnit	Hours
HP(eUnit)	Heat production from eUnit	MWh/month
HPCap(eUnit)	Peak heat capacity on eUnit	MW
PeakElecLoadAnnual(eUnit)	Annual max	MWh/month
PHP(eUnit)	Process Heat production from eUnit	MWh/month
PHPCap(eUnit)	Peak process heat capacity on eUnit	MW
TurnOns(eUnit)	Number of turn-on for eUnit	
FullLoadHours(eUnit)	Number of full load hours for eUnit	Hours
AccFullLoadHours(eUnit)	Accumulates the full load hours over the year	Hours
AccAllYearsFullLoadHours(eUnit)	Accumulates the full load hours over the years in the planning period	Hours

Table 4.4: Functions getting production information on energy conversion units.

CP

Returns the monthly amount of Cooling produced on a specified energy conversion unit.

Syntax

CP(*eUnit*)

Argument	Description
<i>eUnit</i>	The Name of the specified energy conversion unit
Returning value	Monthly amount of cooling produced on energy conversion unit
Returning unit	MWh/month

Example

CP(*Electric Chiller*)

CPCap

Returns the monthly peak cooling production load realised on a specified energy conversion unit.

Syntax

CPCap(*eUnit*)

Argument	Description
<i>eUnit</i>	The Name of the specified energy conversion unit
Returning value	Monthly peak cooling production load on specified energy conversion unit
Returning unit	MW

Example *CPCap(Absorption chiller)*

EC

Returns the monthly amount of electricity consumed by a specified energy conversion unit in a specified "Period of Priority".

Syntax *EC(eUnit,PriorityPeriod)*

Argument	Description
<i>EUnit</i>	The Name of the specified energy conversion unit
PriorityPeriod	Name of priority period or "All periods"
Returning value	Monthly amount of electricity Consumed
Returning unit	MWh/month

Description Electricity consumed by a specified energy conversion unit in a specified "priority period"-name

Examples *EC(CHP;PeakLoad)*
EC(CHP;All Periods)

ECCap

Returns the monthly peak electricity consumption load realised on a specified energy conversion unit.

Syntax *ECCap(eUnit)*

Argument	Description
<i>eUnit</i>	The Name of the specified energy conversion unit
Returning value	Monthly peak electricity consumption load on specified energy conversion unit
Returning unit	MW

Example *ECCap(Absorption chiller)*

ElectricCapacity

Returns the monthly peak electric production load on a specified energy conversion unit.

Syntax ElectricCapacity(*eUnit*)

Argument	Description
<i>eUnit</i>	The Name of the specified energy conversion unit
Returning value	Monthly peak electric load
Returning unit	MW

Description Monthly peak electric load on specified energy conversion unit

Examples ElectricCapacity(CHP)

EP

Returns the monthly amount of electricity produced on a specified energy conversion unit in a Priority period name specified in “Electricity markets”.

Syntax EP(*eUnit*,*PriorityPeriod*)

Arguments	Description
<i>eUnit</i>	The Name of the specified Energy conversion unit
<i>PriorityPeriod</i>	Name of priority period or “All periods”
Returning value	Monthly amount of electricity produced on energy conversion unit
Returning unit	MWh/month

Description Electricity produced on a specified energy conversion unit in a specified “priority period”-name

Examples EP(CHP;PeakLoad) return monthly electricity production from unit “CHP” in priority period “PeakLoad”.

EP(CHP;All Periods) return monthly electricity production from unit “CHP” in all periods.

EPCap

Returns the monthly peak electricity production load realised on a specified energy conversion unit.

Syntax EPCap(*eUnit*)

Argument	Description
<i>eUnit</i>	The Name of the specified energy conversion unit
Returning value	Monthly peak electricity production load on specified energy conversion unit
Returning unit	MW

Example EPCap(Absorption chiller)

FC

Returns the monthly amount of fuel consumed by a specified energy conversion unit.

Syntax

FC(eUnit)

Argument	Description
<i>eUnit</i>	The Name of the specified energy conversion unit
Returning value	Monthly amount of fuel consumed by eUnit
Returning unit	MWh/month

Example

FC(Boiler 1) returns fuel consumed by "Boiler 1"

FCCap

Returns the peak fuel consumption load occurring on a specified energy conversion unit during a month.

Syntax

FCCap(eUnit)

Argument	Description
<i>eUnit</i>	The Name of the specified energy conversion unit
Returning value	Monthly peak fuel load on eUnit
Returning unit	MW/month

Example

FCCap(Boiler 1) returns the highest monthly fuel load occurring on "Boiler 1"

HC

Returns the monthly amount of heat consumed by a specified energy conversion unit.

Syntax

HC(eUnit)

Argument	Description
<i>eUnit</i>	The Name of the specified energy conversion unit
Returning value	Monthly amount of heat consumed by a energy conversion unit
Returning unit	MWh/month

Examples

HC(Absorption chiller) return the monthly heat consumption on "Absorption chiller"

HCCap

Returns the monthly peak heat consumption load realised on a specified energy conversion unit.

Syntax HPCap(*eUnit*)

Argument	Description
<i>eUnit</i>	The Name of the specified energy conversion unit
Returning value	Monthly peak heat consumption load on eUnitenergy conversion unit
Returning unit	MW/month

Example HCCap(Boiler 1)

HeatBlowoff

Returns the monthly peak heat blowoff realised on a specified energy conversion unit.

Syntax HP(*eUnit*)

Argument	Description
Returning value	Monthly heat rejection for accumulated for all heat rejection units in project
Returning unit	MWh/month

Example HeatBlowOff

HoursOfOperation

Returns the monthly hours of operation on a specified energy conversion unit.

Syntax HoursOfOperation(*eUnit*)

Argument	Description
<i>EUnit</i>	The Name of the specified Energy conversion unit
Returning value	Monthly hours of operation
Returning unit	Hours of operation/month

Description This function returns monthly hours of operation on an energy conversion unit. Is used when designing operational costs.

Example HoursOfOperation(CHP) returns the number of hours of operation on the energy conversion unit CHP

HP

Returns the monthly amount of heat produced on a specified energy conversion unit.

Syntax HP(*eUnit*)

Argument	Description
<i>eUnit</i>	The Name of the specified energy conversion unit
Returning value	Monthly amount of heat produced on energy conversion unit
Returning unit	MWh/month

Example HP(Boiler 1)

HPCap

Returns the monthly peak heat production load realised on a specified energy conversion unit.

Syntax HP(*eUnit*)

Argument	Description
<i>eUnit</i>	The Name of the specified energy conversion unit
Returning value	Monthly peak heat production load on specified energy conversion unit
Returning unit	MWh/month

Example HP(Boiler 1)

PeakElectricLoadAnnual

Returns the annual peak electric production load on a specified energy conversion unit.

Syntax PeakElectricLoadAnnual (*eUnit*)

Argument	Description
<i>eUnit</i>	The Name of the specified energy conversion unit
Returning value	Annual peak electric load
Returning unit	MW

Description Annual peak electric load on specified energy conversion unit

Examples PeakElectricLoadAnnual (*CHP*)

PHCCap

Returns the monthly peak process heat consumption load realised on a specified energy conversion unit.

Syntax `PHPCap(eUnit)`

Argument	Description
<i>eUnit</i>	The Name of the specified energy conversion unit
Returning value	Monthly peak process heat consumption load on specified energy conversion unit
Returning unit	MW/month

Example `PHCCap(Boiler 1)`

PHP

Returns the monthly amount of process heat produced on a specified energy conversion unit.

Syntax `PHP(eUnit)`

Argument	Description
<i>eUnit</i>	The Name of the specified energy conversion unit
Returning value	Monthly peak process heat production load on specified energy conversion unit
Returning unit	MW/month

Example `PHP(Boiler 1)`

PHPCap

Returns the monthly peak process heat production load realised on a specified energy conversion unit.

Syntax `PHPCap(eUnit)`

Argument	Description
<i>eUnit</i>	The Name of the specified energy conversion unit
Returning value	Monthly amount of process heat produced on energy conversion unit
Returning unit	MWh/month

Example `PHPCap(Boiler 1)`

TurnOns

Returns the monthly amount of turn-on on a specified energy conversion unit.

Syntax TurnOns(*eUnit*)

Argument	Description
-----------------	--------------------

<i>EUnit</i>	The Name of the specified Energy conversion unit
Returning value	Monthly number of turn-on
Returning unit	Turn-on/month

Description This function returns monthly number of turn-on on an energy conversion unit. Is used when designing operational costs.

Example *TurnOns(CHP)* returns the number of turn-on on the energy conversion unit CHP

FullLoadHours

Returns the monthly amount of full load hours on a specified energy conversion unit.

Syntax FullLoadHours(*eUnit*)

Argument	Description
-----------------	--------------------

<i>EUnit</i>	The Name of the specified Energy conversion unit
Returning value	Monthly number of full load hours
Returning unit	hours/month

Description This function returns monthly number of full load hours on an energy conversion unit.

Example *FullLoadHours(CHP)* returns the number of full load hours on the energy conversion unit CHP.

AccFullLoadHours

Returns the accumulated amount over a year of full load hours on a specified energy conversion unit.

Syntax AccFullLoadHours(*eUnit*)

Argument	Description
-----------------	--------------------

<i>EUnit</i>	The Name of the specified Energy conversion unit
--------------	--

Returning value Accumulated number of full load hours over the year value

Returning unit hours

Description This function returns the accumulated number of full load hours on an energy conversion unit. Typically, it is used when units obtain grant until a certain amount of full load hours, or for service intervals.

Example *AccFullLoadHours(CHP)* returns the number of full load hours on the energy conversion unit CHP accumulated over the year.

AccAllYearsFullLoadHours

Returns the accumulated amount over the planning period of full load hours on a specified energy conversion unit.

Syntax `AccAllYearsFullLoadHours(eUnit)`

Argument	Description
<i>EUnit</i>	The Name of the specified Energy conversion unit
Returning value	Accumulated number of full load hours over the planning years
Returning unit	hours

Description This function returns the accumulated number of full load hours on an energy conversion unit. Typically, it is used when units obtain grant until a certain amount of full load hours, or for service intervals.

Example *AccAllYearsFullLoadHours(CHP)* returns the number of full load hours on the energy conversion unit CHP accumulated over the planning period.

Demands

In Table 4.5 is found the function that are used for getting the demands

Name	Returns	Unit
CD(coolingdemand)	Cooling demand	MWh/month
ED(electricitydemand)	Electricity demand	MWh/month
HD(heatdemand)	Heat demand	MWh/month
PHD(Processheatdemand)	Process Heat demand	MWh/month
PeakElectricityDemand (Period)	The peak value for the month for electricity demand for Period	MW

Table 4.5: Functions getting demands.

CD

Returns the monthly cooling demand.

Syntax `CD(DemandName)`

Argument	Description
----------	-------------

<i>DemandName</i>	The Name of the specified cooling demand
Returning value	Monthly cooling demand
Returning unit	MWh/month

Description This function returns monthly heat demand.

Example *CD(Cooling Demand)* returns the monthly cooling demand of demand named "Cooling Demand"

HD

Returns the monthly heat demand.

Syntax HD(*DemandName*)

Argument	Description
----------	-------------

<i>DemandName</i>	The Name of the specified Heat Demand
Returning value	Monthly heat demand
Returning unit	MWh/month

Description This function returns monthly heat demand.

Example *HD(Heat Demand 1)* returns the monthly heat demand of demand named "Heat Demand 1"

ED

Returns the monthly electric demand.

Syntax ED(*DemandName*)

Argument	Description
----------	-------------

<i>DemandName</i>	The Name of the specified Electricity Demand
Returning value	Monthly electricity demand
Returning unit	MW/month

Description This function returns monthly heat demand.

Examples *ED(Electricity Demand)* returns the monthly electricity demand of demand named "Electricity Demand"

PeakElectricDemand

Returns the monthly peak of a specified electric demand.

Syntax PeakElectricDemand(*DemandName*)

Argument	Description
----------	-------------

<i>DemandName</i>	The Name of the specified Electricity Demand
Returning value	Monthly peak electric demand
Returning unit	MW/month

Description This function returns monthly peak of heat demand.

Example *PeakElectricDemand(Electricity Demand)* returns the monthly peak of electricity demand of demand named "Electricity Demand"

4.5.3 Other Functions

Name	Returns	Unit
HeatValue (Fuel)	Calorific value for the fuel	MWh/unit
IndeksFaktor		-
Index	Monthly value of specified index	-
Month(no)	Returns the number 1 for month no, 0 for others	-
QI(value1;value2)	Quality Index, UK	
<TimeSeriesSymbol>(_)	Actual "Timeseries"-value	-
UnitOfDemand(Demand)	Calorific value for the demand (If the unit e.g. are GJ the function will return 0,2777777 MWh/GJ)	MWh/unit

Table D.4: Other functions

HeatValue

Returns a conversion factor from MWh to the original unit of the HeatValue used when defining a specified fuel.

Syntax

HeatValue(FuelName)

Argument	Description
<i>FuelName</i>	The Name of a specified fuel
Returning value	Conversion factor
Returning unit	MWh/<unit> Where <unit> is the original unit used when defining the specified fuel

Description

This function returns a conversion factor from MWh to original unit of the HeatValue used when defining a specified fuel. **This function is normally used for converting the used amount of fuel in MWh to its original unit.**

Example

HeatValue(Natural gas). Consider that the heat value of the fuel "Natural gas" is defined as 11 kWh/nm³. Then the function will return 1MWh/11kWh/Nm³ pr MWh equal to 1/11000 MWh/Nm³

Indeksfaktor (Danish only)

This function is establish for Danish use only. The function is used for calculating the production independent subsidy for CHP production.

Syntax

Indeksfaktor(TimeseriesSymbol,indexvalue)

Argument	Description
----------	-------------

<i>Timeseries symbol</i>	The symbol Name of the specified time series
<i>Indexvalues</i>	The index
Returning value	Index factor
Returning unit	-

Description This function returns the monthly “indeksfaktor” based on the monthly average spot price and an index based on process development.

Example Indeksfaktor(DK1Spot10;1,223) ice

<Timeseriessymbol>(_)

Returns the actual value of the time series

Syntax <Timeseriessymbol>(_)

Argument	Description
(_)	
Returning value	The actual value of the time series
Returning unit	Unit of time series

Description This function returns monthly average value of the time series specified with its symbol

Example T(_) returns the monthly average value of the specified time series with symbol “T”

Month

Month is a function returning the value 1 in chosen month and zero in the other months.

Syntax Month(number)

Argument	Description
<i>Number</i>	Month number in year 1=January, 2=February etc.
Returning value	1 if true, 0 if false
Returning unit	-

Description This function returns 1 if the month number in function match the actual month in calculation otherwise it returns 0 (zero). **This function is** used in situations where an annual payment takes place in a specific month.

Examples *Month(3)*. This function return the value 1 if the calculation month is March and otherwise the value 0.

UnitOfDemand

Returns a conversion factor from MWh to the original unit used when defining a specified demand.

Syntax UnitOfDemand(*DemandName*)

Argument	Description
<i>DemandName</i>	The Name of a specified demand
Returning value	Conversion factor
Returning unit	MWh/<unit> Where <unit> is the original unit used when defining the specified fuel

Description This function returns a conversion factor from MWh to original energy unit used when defining a specified demand. **This function is** normally used for converting a demand in MWh to its original unit.

Example *UnitOfDemand(HeatDemand 1)*. Consider that the used “unit of demand” is GJ. Then the function will return 0,2777777 MWh/GJ

QI

Quality index is especially used in **Great Britain** to describe the “Quality” of an energy conversion unit.

Syntax QI(*el-factor*; *heat-factor*)

Argument	Description
<i>el-factor</i>	Quality coefficient for power
<i>heat-factor</i>	Quality coefficient for heat
Returning value	Index
Returning unit	None

Description QI defines the Quality Index defined as

$$QI(\text{el-factor}; \text{heat-factor}) = \text{el-factor} * \text{Efficiency}_{\text{power}} + \text{heat-factor} * \text{Efficiency}_{\text{heat}}$$

$$\text{Efficiency}_{\text{power}} = EP/FC$$

$$\text{Efficiency}_{\text{heat}} = (HP - HR)/FC$$

Where:

EP= annual power supply (MWh_e)

HP= annual heat supply (MWh_{th})

FC= annual fuel use (MWh)

HR= annual heat rejection (MWh)

El-factor is a coefficient for power, related to alternative electricity supply options. Similarly, heat-factor is a coefficient for heat generation, related to alternative heat generation options. These coefficients vary to reflect conditions affecting particular classes of CHP plant. For a project, which supplies electricity only, Efficiency_{heat} is zero. For a project which supplies heat only, Efficiency_{power} is zero.

QI is annual based. This means the result is only present in the last month of the calculation year.

Example *QI(200;125)*

Result

Returns the Result from the income statement (after taxation).

Syntax Result

Argument	Description
Returning value	The result from the income statement of the actual fiscal year
Returning unit	<currency>

4.6 Functions used only in Taxation

Name	Returns
ResultBeforeTax	The result of the actual fiscal year before tax
LossCarriedForward(n)	The last n years loss reduced with eventually profits from the fiscal years
Increment(amount;n1;n2)	This function increments from zero with the value "amount" from fiscal year n1 to n2. Example : Increment(10;2;4) gives the result Fiscal year 1 : 0 Fiscal year 2 : 10 Fiscal year 3 : 20 Fiscal year 4 : 30 Fiscal year 5 : 30
Year(n)	1 in the fiscal year n, 0 otherwise Example : Year(1)+Year(2) returns 1 in first and second fiscal year, 0 otherwise

Table D.7: Taxation functions available for user-defined formulas.

Increment

This function represent a step-function to model a linear development of a taxation percentage.

Syntax Increment(Value,FyearNo1,YearNo2)

Argument	Description
Value	Annual increment
YearNo1	First year with increment
YearNo2	Last year with increment
Returning value	Annual values
Returning unit	-

Description **This function is** a step-function to be used for modelling changes in taxation rate. The function returns 0 (zero) until the number of first year where it returns the value used for argument. The function then increment with this value each year until number of last year. In the years after it will return the value reached in the last year with changes.

Example Increment(10;2;4) return the following results for

Fiscal year 1 : 0
Fiscal year 2 : 10
Fiscal year 3 : 20
Fiscal year 4 : 30

Fiscal year 5 : 30

Fiscal year n : 30

LossCarriedForward

Syntax LossCarriedForward(*Years*)

Argument	Description
<i>Years</i>	The number of years for which it is allowed to carry a deficit of years income statement forward
Returning value	Amount of loss carried forward to be used in actual year
Returning unit	<currency>

Description In the tax legislation, it is often allowed to carry losses forward. For instance if the income statement in a specific year comes out with a negative result this result may be subtracted from the positive result of a forthcoming year bringing down the tax payment of this forthcoming year. The subtraction will be done in the first possible year.

Example *LossCarriedForward(5)*. In this case, a deficit in an actual year may be used to bring down tax payments in up to five years.

ResultBeforeTax

Returns the result of the income statement of the actual fiscal year before taxation.

Syntax ResultBeforeTax

Argument	Description
Returning value	The result of the actual fiscal year before tax
Returning unit	<currency>

Year

A logical function returning 1 if the argument correspond with the actual year number in tax calculation, otherwise it returns 0 (zero)

Syntax Year(*YearNo*)

Argument	Description
<i>YearNo</i>	The year number
Returning value	1 if true, 0 if false
Returning unit	-

Description A logical function returning 1 if the argument correspond with the actual year number in tax calculation, otherwise it returns 0 (zero)

Example *Year(1)+Year(2)* returns 1 in first and second fiscal year, 0 otherwise

4.7 Functions used only in Annual Key Figures

In an account project there is an option of formatting a report with user defined key figures. To establish those key figures the following functions are available.

Long version	Short version
CashAccount	CA
Depreciations	D
ExtraordinaryIncome	EI
FCAnnualMWh(ProductionUnit)	
FinancialExpenditures	FE
FixedAssets	FA
LongTermLiabilities	LTL
OperationExpenditures	OE
OtherCurrentAssets	OCA
OwnersCapital	OC
Reserves	
Result	
Revenues	R
ShortTermLiabilities	STL
Tax	T
TransferredResult	TR

Table D.8: Functions available for defining annual key figures

Most functions are available in both a long and a short version. Therefore, the function "OperationExpenditures" is equal "OE". Both functions return the annual operation expenditures.

CashAccount

Returns the cash account from the income statement.

Syntax

CashAccount or CA

Argument

Description

Returning value	The Cash Account from the income statement of the actual fiscal year
Returning unit	<currency>

Depreciation

Returns the Depreciations from the income statement.

Syntax

Depreciation or D

Argument

Description

Retur value	The operation expenditures from the income statement of the actual fiscal year
Returning unit	<currency>

ExtraordinaryIncome

Returns the extraordinary income from the income statement. Extra ordinary income is grants defined in financing.

Syntax ExtraordinaryIncome or EI

Argument	Description
Returning value	The extraordinary income from the income statement of the actual fiscal year
Returning unit	<currency>

FCAnnualMWh

Returns valued from a time series established under external conditions or demands

Syntax FCAnnualMWh(*Productionunit*)

Argument	Description
<i>Productionunit</i>	The name of a specific energy conversion unit.
Returning value	The annual fuel consumption measured in MWh
Returning unit	MWh/year

Description Is to be used if the development in the annual fuel consumption is wanted in the annual key figures report.

Examples *FCAnnualMWh(Woodboiler)*

The annual fuel consumption of energy conversion unit named "Woodboiler".

Financial Expenditures

Returns the operation expenditures from the income statement. The financial expenditures include payment on loans an interest on cash account.

Syntax FinancialExpenditures or FE

Argument	Description
Returning value	The financial expenditure from the income statement of the actual fiscal year
Returning unit	<currency>

FixedAssets

Returns the Fixed Assets from the balance sheet. The fixed assets is here the value of an investment which is still left for depreciation

Syntax FixedAsset or FA

Argument	Description
Returning value	The fixed asset from the balance sheet of the actual fiscal year
Returning unit	<currency>

LongTermLiabilities

Returns the long-term liabilities from the balance sheet. The long-term liabilities equal the remaining debt on loans.

Syntax LongTermLiabilities or LTL

Argument	Description
Returning value	The long term liabilities from the balance sheet of the actual fiscal year
Returning unit	<currency>

OperationExpenditures

Returns the operation expenditures from the income statement.

Syntax OperationExpenditures or OE

Argument	Description
Returning value	The operation expenditures from the income statement of the actual fiscal year
Returning unit	<currency>

OtherCurrentAssets

Returns short term liabilities from the balance sheet. Other current assets are revenues that are delayed. This could be heat produced in the last month of the fiscal year but paid in the start of the next fiscal year.

Syntax OtherCurrentAssets or OCA

Argument	Description
Returning value	Other current assets from the balance sheet of the actual fiscal year
Returning unit	<currency>

OwnersCapital

Returns owners capital from the balance sheet. The owners capital is the owners capital defined as such in financing.

Syntax OwnersCapital or OC

Argument	Description
Returning value	The Owners capital from the balance sheet of the actual fiscal year
Returning unit	<currency>

Reserves

Returns the reserves.

Syntax

Reserves

Argument	Description
-----------------	--------------------

Returning value	Reserves
Returning unit	<currency>

Revenues

Returns the revenues from the income statement.

Syntax

Revenues or R

Argument	Description
-----------------	--------------------

Returning value	The revenues from the income statement of the actual fiscal year
Returning unit	<currency>

ShortTermLiabilities

Returns other current assets from the balance sheet. Other current assets are operational payments that are delayed. This could be fuel used in the last month of the fiscal year but paid in the start of the next fiscal year.

Syntax

ShortTermLiabilities or STL

Argument	Description
-----------------	--------------------

Returning value	Other current assets from the balance sheet of the actual fiscal year
Returning unit	<currency>

Tax

Returns the tax payments from the income statement.

Syntax

Tax or T

Argument	Description
-----------------	--------------------

Returning value	The tax payments from the income statement of the actual fiscal year
Returning unit	<currency>

TransferredResult

Returns the transferred result from the income statement.

Syntax

TransferredResult or TR

Argument	Description
-----------------	--------------------

Returning value	The transferred result from the income statement of the actual fiscal year
Returning unit	<currency>

Appendices

A Import data from a spreadsheet to a time series

To import data from a spreadsheet into a time series it is important to use a date and time format used in energyPRO .

To secure that, the recommended way of doing this is to copy a line from an energyPRO time series into a spreadsheet. Start creating a time series for e.g. the ambient temperature in the External conditions folder. Type values for date and time in the first line. Press the Copy all button and the line is copied to the clipboard.

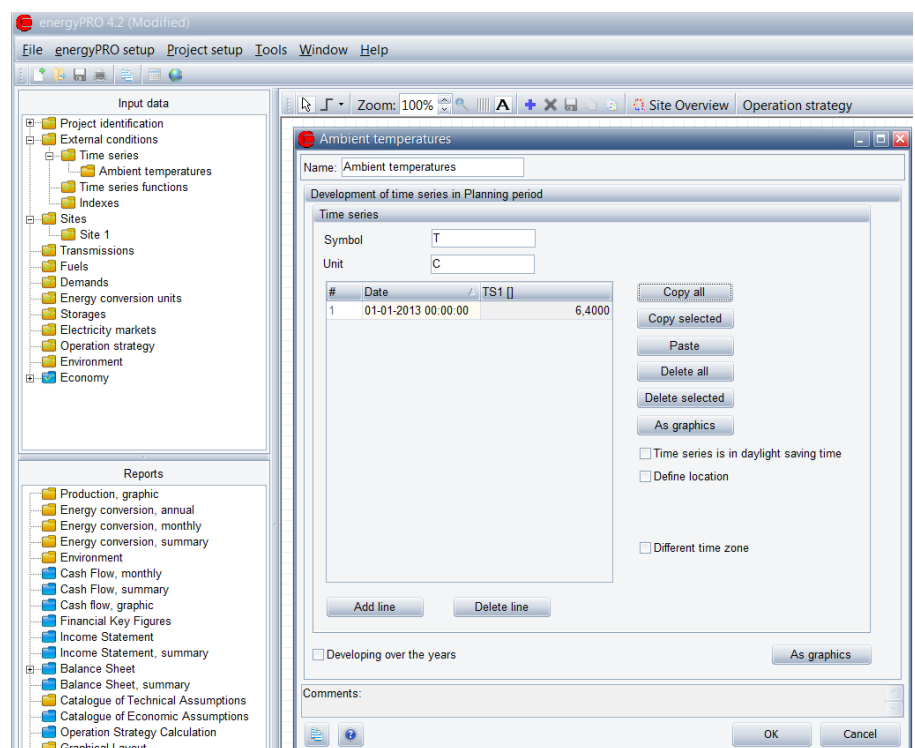

Figure A.1: Time series with one value specified

Open the spreadsheet to be used. In this example is used a spreadsheet with month, day and ambient temperature specified.

	A	B	C	D	E	F	G	H	I	J	K
1	Month	Day	Ambient temp								
2		1	1	6,4							
3		1	2	5,8							
4		1	3	5							
5		1	4	3,1							
6		1	5	1,4							
7		1	6	-0,5							
8		1	7	-4,6							
9		1	8	-2,6							
10		1	9	0,6							
11		1	10	3,2							
12		1	11	6,1							
13		1	12	4,4							
14		1	13	6,9							
15		1	14	6,6							
16		1	15	5,1							
17		1	16	6							
18		1	17	5,7							
19		1	18	5,2							
20		1	19	7,6							
21		1	20	7,3							
22		1	21	5,2							
23		1	22	4,5							

Figure A.2: Example of spread sheet with ambient temperature specified.

Pasting the date and time from clipboard into the spreadsheet.

	A	B	C	D	E	F	G	H	I	J	K
1	Month	Day	Ambient temp								
2		1	1	6,4		01-01-2002	00:00:00	6,4			
3		1	2	5,8							
4		1	3	5							
5		1	4	3,1							
6		1	5	1,4							
7		1	6	-0,5							
8		1	7	-4,6							
9		1	8	-2,6							
10		1	9	0,6							
11		1	10	3,2							
12		1	11	6,1							
13		1	12	4,4							
14		1	13	6,9							
15		1	14	6,6							
16		1	15	5,1							
17		1	16	6							
18		1	17	5,7							
19		1	18	5,2							
20		1	19	7,6							
21		1	20	7,3							
22		1	21	5,2							
23		1	22	4,5							

Figure A.3: The date and time from energyPRO is now copied into the spread sheet.

Use this format for date and time to create new columns for the ambient temperature:

	A	B	C	D	E	F	G	H	I	J	K
1	Month	Day	Ambient temp								
2		1	1	6,4		01-01-2002	00:00:00	6,4			
3		1	2	5,8		02-01-2002	00:00:00	5,8			
4		1	3	5		03-01-2002	00:00:00	5			
5		1	4	3,1		04-01-2002	00:00:00	3,1			
6		1	5	1,4		05-01-2002	00:00:00	1,4			
7		1	6	-0,5		06-01-2002	00:00:00	-0,5			
8		1	7	-4,6		07-01-2002	00:00:00	-4,6			
9		1	8	-2,6		08-01-2002	00:00:00	-2,6			
10		1	9	0,6		09-01-2002	00:00:00	0,6			
11		1	10	3,2		10-01-2002	00:00:00	3,2			
12		1	11	6,1		11-01-2002	00:00:00	6,1			
13		1	12	4,4		12-01-2002	00:00:00	4,4			
14		1	13	6,9		13-01-2002	00:00:00	6,9			
15		1	14	6,6		14-01-2002	00:00:00	6,6			
16		1	15	5,1		15-01-2002	00:00:00	5,1			
17		1	16	6		16-01-2002	00:00:00	6			
18		1	17	5,7		17-01-2002	00:00:00	5,7			
19		1	18	5,2		18-01-2002	00:00:00	5,2			
20		1	19	7,6		19-01-2002	00:00:00	7,6			
21		1	20	7,3		20-01-2002	00:00:00	7,3			
22		1	21	5,2		21-01-2002	00:00:00	5,2			
23		1	22	4,5		22-01-2002	00:00:00	4,5			

Figure A.4: Columns with the correct date and time format is now created.

Now you can copy the columns into the time series in energyPRO:

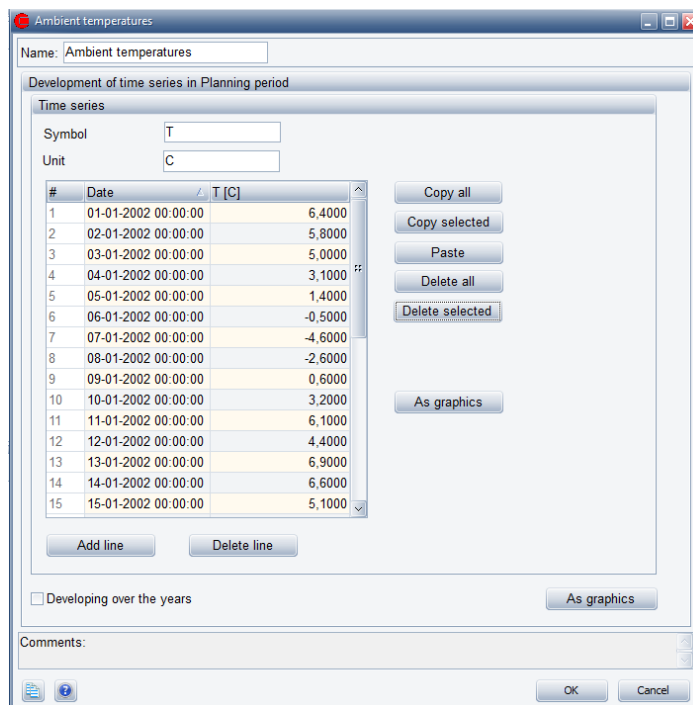

Figure A.5: Data from the spread sheet copied into the time series.

B How to save as a .pdf file

A report can be saved in several formats. If you would like to e-mail the report to someone, the .pdf – format (or Acrobat Reader) will often be appropriate.

In the Report Preview, you chose File and Save as.

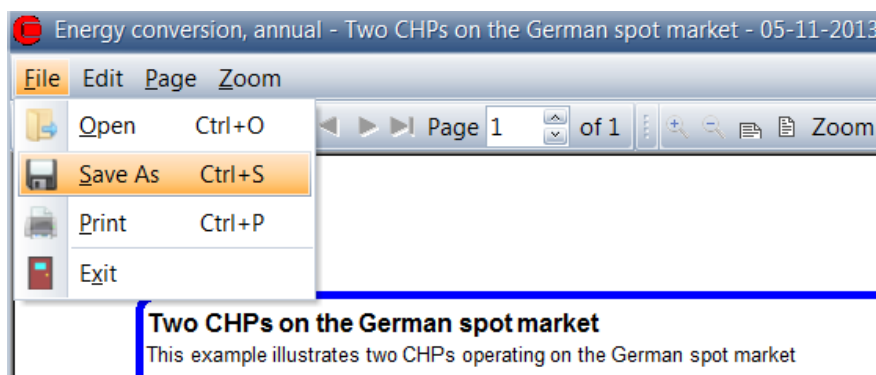

Figure B.1: Choose "File" and "Save as" in the Report Preview

In the field "Save as type", you can select the wanted format in the list.

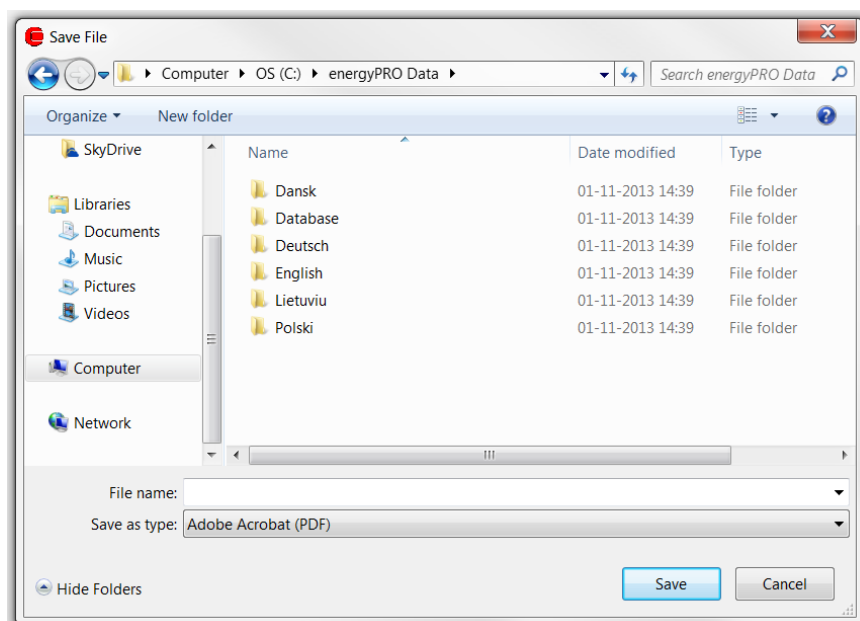

Figure B.2: Select the wanted format in the field "Save as type".

Paste into a document

You can copy a report to the clipboard, either an image or as data. In the report, preview window you chose edit and then copy. Open a document and chose paste.

C How to change the set-up in the graphic reports

It is possible to customize the settings for the graphic reports. Maybe you want to change some colours or maybe you want to make the lines wider.

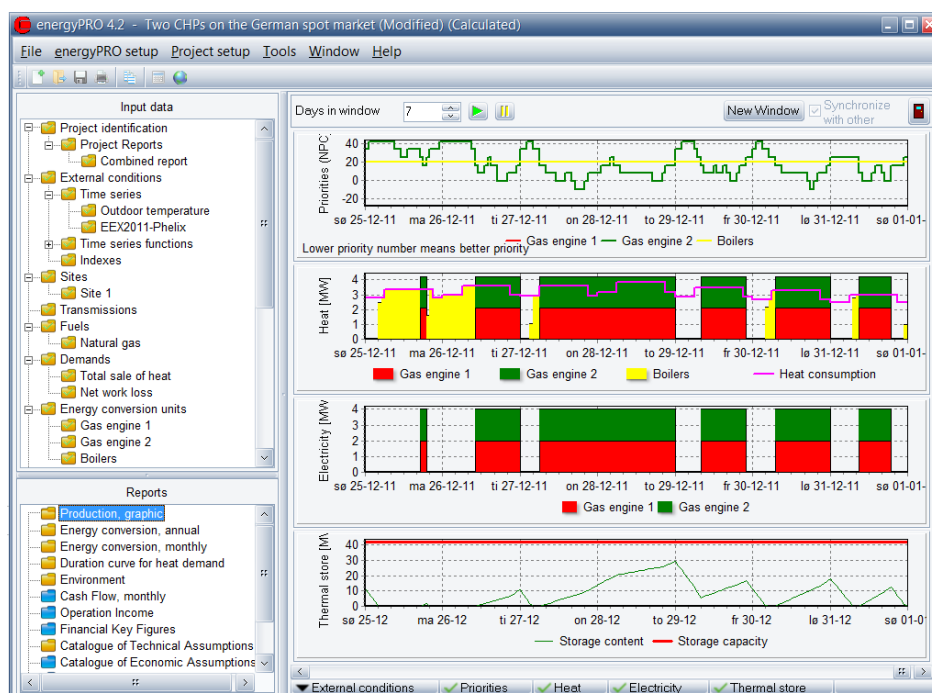

Figure C.1: Graphic report to be changed. Double click on the chart to be able to change the set-up.

If you double click on the graphic, you got the opportunity to change the settings.

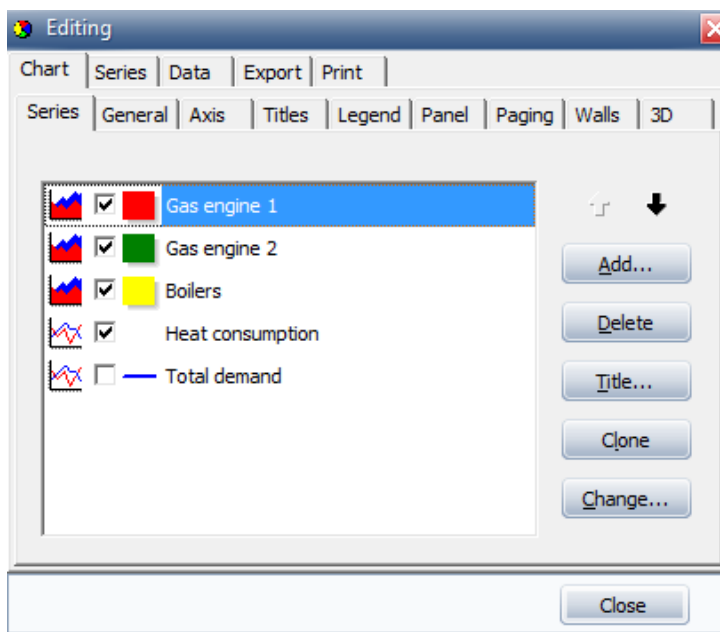

Figure C.2: Changing the settings for the graphic.

Now it is possible to edit the graphic. It is beyond the scope of this user's guide to describe the facilities in details. Please note that you cannot save

your new settings as default values. The graphic report will turn into default values again, when you save the project.

D Interpretation of economy functions when calculating the operation strategy for a production unit

Function	Net heat productioncost	Net cooling production cost
Demand functions		
HD	0	0
ED	0	0
CD	0	0
PHD	0	0
PeakElecLoadAnnual	0	0
PeakElectricDemand	0	0
Energy conversion unit functions		
HP	1	0
EP	ElProd/HeatProd	0
FC	FuelCon/HeatProd	0
EC	ElCon/HeatProd	Elcon/CoolProd
HC	0	1
CP, CoolingProduction	CoolProd/HeatProd	1
HoursOfOperation	1/HeatProd	0
ElectricCapacity	0	0
Turnons	0	0
AccEP	0	0
Other functions		
HeatValue	Unchanged	Unchanged
UnitOfDemand	Unchanged	Unchanged
Month	Unchanged	Unchanged
Index	Unchanged	Unchanged
Indeksfaktor	Unchanged	Unchanged
TSMean,	Unchanged	Unchanged
Functions at system level		
ExportedElectricity	EP	0
ImportedElectricity	EC	EC
ImportedFuel	FC	0
AccExportedElectricity	0	0
AccImportedElectricity	0	0
AccImportedFuel	0	0
APeakExportedElectricity	0	0
APeakImportedElectricity	0	0
PeakExportedElectricity	0	0
PeakImportedElectricity	0	0
PeakImportedFuel	0	0
Spot price functions		
SpotPricesXExportedElectricity	Elec-Spotprice * ExportedElectricity	0
SpotPricesXImportedElectricity	Elec-Spotprice * ImportedElectricity	Elec-Spotprice * ImportedElectricity

Table 0.1: Interpretation of payment functions in energyPRO when calculating operation strategy

Where:

Heatprod	= Heat production capacity
ElPprod	= Electricity production capacity
CoolProd	= Cooling Production capacity
ElCon	= Electricity consumption capacity
FuelCon	= Fuel consumption capacity

All in [MWh] or [kWh]

4.7.1 Electricity demand is present / Private wire / Geschlossenes verteilernetz.

If one or more electricity demands are present in a project the calculation of the operation it affects the automatic calculation of the operation strategy.

First, an additional set of net heat production costs is calculated based on covering the electricity demand. This means that “ExportedElectricity” and “ImportedElectricity” is interpreted as follows:

Function	Return value
ExportedElectricity	0
ImportedElectricity	EC - EP

Based on the two sets of net heat production costs (the “electricity export” and the “covering own electricity demand”) is calculated a weighted average, dependent on the electricity production capacity of the unit and the residual electric electric demand that are not met in each time step. The residual electric demand and hence the priority is calculated dynamically. This means that the priority of a specific production unit in a specific time step is dependent on already planned production on other production units in the time step.

Priority number when residual electricity demand is 0% of electricity production capacity:

$$100\% * \text{“electricity export”} + 0\% * \text{“covering own electricity demand”}$$

Priority number when residual electricity demand is 50% of electricity production capacity:

$$50\% * \text{“electricity export”} + 50\% * \text{“covering own electricity demand”}$$

Priority number when residual electricity demand is 100% or more of electricity production capacity:

$$0\% * \text{“electricity export”} + 100\% * \text{“covering own electricity demand”}$$

